

Modified Vertical Motors

Hardworking. Dependable. Rugged Reliability.

HOLLOSHAFT | SOLID SHAFT | WPI & WPII
TEFC/TEXP | 3-5000 HP

Nidec
NIDEC MOTOR CORPORATION

Countless Solutions. Expert Support.



WE BUILD MORE THAN MOTORS.

WE BUILD RELIABILITY.

Vertical HOLLOSHAFT® Motor Construction

- 1. Lightweight Rugged Canopy Cap** – Protect coupling and bearing from ingress of dirt and water
- 2. Coupling** – Readily accessible and comes in either bolted or self release depending on application
- 3. Lockbar** – Holds shaft in place during adjustment. Will be removed in order to accommodate a Non-Reverse Ratchet
- 4. Lifting Lugs** – Positioned and designed for stability during handling
- 5. Conduit Box** – Can be constructed using cast iron or heavy duty steel to meet NEMA and NEC requirements
- 6. Protected Dual Air Flow Design** – Provides uniform cooling to each side of the motor coils and exceeds NEMA WPI requirements for protection against rodents and foreign material
- 7. Precision Machined Mounting Base** – Clearance and access to mounting holes. Options of different base diameters and bolt hole circles that meet all of NEMA's base dimensions
- 8. High Thrust Angular Contact Bearing** – Bearing is designed and installed to handle maximum thrust with low friction and heating. Options for different thrust handling capabilities: normal, standard high thrust, 175% extra high thrust and 300% extra high thrust
- 9. Oil Fill Plug** – Easy opening/closing T-handle and large opening for easy filling
- 10. Oil Sight Glass Window** – Accessible and easy to read
- 11. Oil Sump** – Large oil sump for proper lubrication and cooling of thrust handling bearings
- 12. Metered Oil Flow** – Minimizes inefficient churning of oil
- 13. Air Deflectors** – directs airflow over stator end-turns for most efficient cooling
- 14. Copper Windings** – Insulated with robust material to protect against damaging voltage spikes and abrasive environments
- 15. Solid Die-Cast Rotor** – Die-Cast aluminum core with integral fan blades to circulate cooling air
- 16. Shaft Grounding** – Used on Inverter duty motors to protect bearings from harmful circulating currents in the shaft and Electrical Discharge Machining (EDM). On larger motors an insulated bearing is used opposite of the shaft grounding device for complete protection of motor bearings.

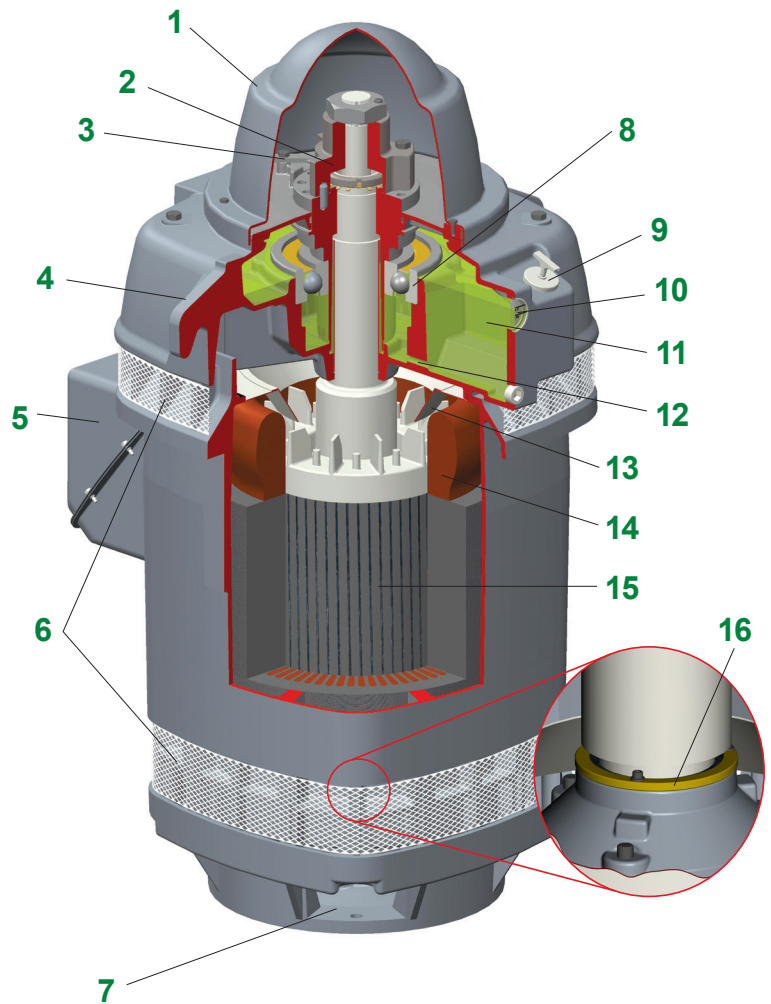

The U.S. MOTORS® brand Vertical HOLLOSHAFT® motor has been a standard in the pumping industry since 1922. These motors are recognized for their longevity, reliability and ease of use. Unique configurations, tailored to a customer's specific requirements, can include enclosure design to minimize the effects of adverse conditions present in turbine, mix flow and propeller pump applications.

TABLE OF CONTENTS

INTRODUCTION..... I-6

MODIFIED VHS - WPI AND TEFC P-1

MODIFIED VSS - WPI AND TEFC P-31

MODIFIED VSS - WPI, SNOWMASTER..... P-63

MODIFIED VSS - TEFC, IN-LINE..... P-65

MODIFIED VSS - TEFC, AERATOR..... P-71

MODIFIED VSS - WPI AND TEFC, NORMAL THRUST P-74

MODIFICATIONS AND ACCESSORIES M-1

ENGINEERING DATA..... M-82

DIMENSION PRINTS..... E-1

* Pricing and adders in this book are effective June 2018 *



GENERAL INFORMATION

PRODUCT
OVERVIEW

IMPORTANT INFORMATION

Nidec Motor Corporation has made every effort to ensure the integrity of the contents of this catalog. However, Nidec Motor Corporation cannot accept responsibility for errors that may have been caused by changing model/catalog numbers, or for typographical or clerical errors in the preparation of this catalog. The motor data and dimensions are provided for reference only. Certified dimensions and performance data will be furnished upon request. Prices are subject to change without notification.

Nidec Motor Corporation does not assume responsibility for the selection, use, or maintenance of any product. Responsibility for the proper selection, use and maintenance of any product within this catalog remains solely with the purchaser and end-user.

The contents of this publication are presented for informational purposes only, and while every effort has been made to ensure their accuracy, except for Nidec Motor Corporation's standard Limited Warranty stated herein, they are not to be constructed as warranties or guarantees, expressed or implied, regarding the products described herein or their use or applicability. Nidec Motor Corporation reserves the right to modify or improve the designs or specifications of such products at any time without notice.

The following is a list of Nidec Motor Corporation's U.S. trademarks for products and services in this catalog. The trademarks followed by the ® symbol are registered with the U.S. Patent and Trademark Office.

ALLGUARD®
CORRO-DUTY®
HOSTILE DUTY®

HOLLOSHAFT®
INVERTER GRADE®
SNOWMASTER™

THERMA SENTRY®
TITAN®
U.S. MOTORS®

VARIDYNE®
EVERSEAL®
INSULIFE™



GENERAL INFORMATION FOR INTEGRAL HORSEPOWER (IHP) MOTORS ON VARIABLE FREQUENCY DRIVES (VFDS)

Variable Frequency Drives (VFD)

A VFD is a type of controller used to vary the speed of an electric motor. The VFD takes a fixed AC voltage and frequency and allows it to be adjusted in order to get different speeds from the motor. Motor speed can be varied by changing the frequency of the input power waveform. The equation below shows how the frequency affects the speed of a three phase induction motor.

$$\text{Speed} = \frac{120 \times \text{Fundamental Input Frequency}}{\text{Number of Motor Poles}}$$

How does a VFD work?

A VFD takes the fixed frequency and voltage sine wave from the power grid or power station and puts it through a few steps in order to allow the VFD user to vary the frequency and in turn control the motor speed. First it rectifies the AC power into DC Power. Because of this step, a term commonly used instead of VFD is inverter. This only describes one step of what the VFD does to the power waveform. Once rectified into a DC voltage the drive sends the power through a set of transistors or switches. These switches can take the DC waveform and by opening and closing at certain speeds and durations can create an output waveform that mimics the sine wave that is required to drive a three phase electric motor. The output waveform is known as a Pulse Width Modulation (PWM) waveform because the waveform is created by multiple pulses of the switches at short intervals.

PULSE WIDTH MODULATION WAVEFORM

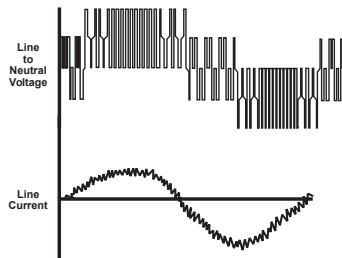

Figure 1 PWM Waveform

What variables should be considered when deciding whether to power a motor with a VFD?

VFD compatibility with motors is complex. As a result, many variables must be considered when determining the suitability of a particular motor for use with a VFD. These variables include:

- Torque requirements (Constant or Variable)
- Speed Range
- Line / System Voltage
- Cable length between the VFD and the motor
- Drive switching (carrier) frequency
- Motor construction
- VFD dv/dt
- High temperatures or high humidity
- Grounding system

*This information applies only to Integral Horsepower (IHP) motors as defined on the Agency Approval page, under UL® & CSA® listings where indicated.

Wider speed ranges, higher voltages, higher switching frequencies, insufficient grounding and increased cable lengths all add to the severity of the application and, therefore, the potential for premature motor failure.

How does a VFD affect the motor?

There are many things to consider when a motor is powered using a VFD or PWM power. When a motor is powered by a PWM waveform the motor windings very often see a large differential voltage, either from phase to phase or turn to turn. When the voltage differential becomes large enough it creates a reaction at the molecular level that converts available oxygen into O₃. This phenomenon is called partial discharge or corona. This reaction creates energy in the form of light and heat. This energy has a corrosive effect on the varnish used to protect the motor windings. PWM waveforms can also magnify shaft voltages which lead to arcing across the bearing and causing premature bearing failure. Corrective action must be taken to mitigate these issues that arise when using an electric motor with a VFD.

How do I protect the motor?

Nidec Motor Corporation (NMC) has developed specific motor designs to decrease the harmful effects that a VFD can have on a motor. NMC's INVERTER GRADE® insulation system is the first line of defense against corona and phase to phase faults that can be common when a motor is powered using a PWM waveform. The INVERTER GRADE® insulation system is standard on all of NMC's Inverter Duty products. Along with the INVERTER GRADE® insulation, thermostats are installed as a minimum protection against over heating the motor. Special consideration must also be given to bearings in motors powered by VFD's. In order to create a low resistance path to ground for built up shaft voltages a shaft grounding device can be used. On larger horsepower motors an insulated bearing system should be used in conjunction with the shaft grounding device when installed, to force the stray shaft voltages to ground. The bearing failures are more prominent on motors with thrust handling bearings. NMC has created an Inverter Duty vertical motor line that not only uses the INVERTER GRADE® insulation system, but that also comes standard with a shaft grounding device. On motors that are 100 HP and greater the thrust bearing is also insulated for additional protection.

What does "Inverter Duty" mean?

An Inverter Duty motor should describe a motor that helps mitigate potential failure modes of a motor that is powered by a VFD. Inverter duty motor windings should be able to withstand the voltage spikes per NEMA MG1 Part 31.4.4.2 and protect against overheating when the motor is run at slow speeds. On thrust handling bearings, it is apparent that the bearings require additional protection. Inverter Duty vertical motors should have a shaft grounding device to protect the motor bearings from fluting due to voltage discharge through the bearing. On larger motors (100HP and larger) the shaft should also be electrically isolated from the frame in order to aid the shaft grounding ring in discharging the shaft voltages to ground.



MOTOR/ INVERTER COMPATIBILITY

Thermal Overloads and Single Phase Motors

Motors with thermal overloads installed may not operate properly on a VFD. The current carrying thermal overload is designed for sine wave power. Operation on a VFD may cause nuisance tripping or potentially not protect the motor as would be expected on line power. Thermostats or thermistors installed in the motor and connected properly to the VFD may provide suitable thermal overload protection when operating on a VFD. (consult codes for installation requirements)

Single phase motors and other fractional horsepower ratings are not designed to be operated on a VFD. Within Nidec Motor Corporation standard products, all motors NEMA^{®†} 48 frame (5.5" diameter) and smaller are not suitable for VFD applications. Three phase 56 and 143/145 frame applications should be noted on the catalog price page; or if in doubt ask a Nidec Motor Corporation technical representative for recommendations on compatibility with a VFD.

Slow Speed Motors

Motors with a base design of slower than six poles require special consideration regarding VFD sizing and minimizing harmonic distortion created at the motor terminals due to cable installation characteristics. Additional external PWM waveform filters and shielded motor cables designed for PWM power may be required to provide acceptable motor life. Harmonic distortion on the output waveform should be kept to a minimum level (less than 10%) mismatch impedance.

690V Applications

Motors that are rated for 690VAC and that will be powered by 690VAC PWM VFDs require the use of an external filter to limit peak voltage spikes and the use of an INVERTER GRADE[®] motor. Where available, an alternative to using an output filter is to upgrade to a 2300V insulation system.

Low Voltage TITAN[®] Motors

When using 449 frame and larger motors on PWM type VFDs consider the use of an external filter and shielded motor cables designed for PWM power to minimize harmonic distortion and peak voltages at the motor terminals. Harmonic distortion on the output waveform should be kept to a minimum level (less than 10%).

Bearing Currents Related to PWM Waveforms

Due to the uniqueness of this condition occurring in the field, protection of the motor bearings from shaft currents caused by common mode voltages is not a standard feature on sine wave or Inverter Duty motor products, unless explicitly noted. Some installations may be prone to a voltage discharge condition through the motor bearings called Electrical Discharge Machining (EDM) or fluting.

EDM damage is related to characteristics of the PWM waveform, and the VFD programming, and installation factors.

Bearing EDM as a result of VFD waveform characteristics may be prevented by the installation of a shaft grounding device such as a brush or ring and/or correction of the installation characteristics causing the shaft voltage condition. Insulated bearing(s) may be required. VFD filters may be used if bearing fluting is to be mitigated.

Bearing Protection on Inverter Duty Vertical Motors

All U.S. MOTORS[®] brand "Inverter Duty" vertical products have a shaft grounding system that allows damaging shaft currents a low resistance path to ground. **Bearings on vertical motors fed by VFD power without this bearing protection are not covered under any warranty.** All other bearing failure is covered per NMC's standard warranty. An electric motor repair shop approved to service U.S. MOTORS[®] brand motors must verify that the cause of the bearing failure was not due to EDM damage.

Multiple Motors on a Single VFD

Special considerations are required when multiple motors are powered from a single VFD unit. Most VFD manufacturers can provide guidelines for proper motor thermal considerations and starting/stopping of motors. Cable runs from the VFD and each motor can create conditions that will cause extra stress on the motor winding. Filters may be required at the motor to provide maximum motor life.

Grounding and Cable Installation Guidelines

Proper output winding and grounding practices can be instrumental in minimizing motor related failures caused by PWM waveform characteristics and installation factors. VFD manufacturers typically provide detailed guidelines on the proper grounding of the motor to the VFD and output cable routing. Cabling manufacturers provide recommended cable types for PWM installations and critical information concerning output wiring impedance and capacitance to ground.

Vertical Motors on VFDs

Vertical motors operated on VFD power present unique conditions that may require consideration by the user or installation engineer:

- Locked rotor and drive tripping caused by non-reversing-ratchet operation at low motor speeds. It is not recommended to operate motors at less than 1/4 of synchronous speed. If slow speeds are required contact NMC engineering.
- Unexpected / unacceptable system vibration and or noise levels caused by the torque pulsation characteristics of the PWM waveform, a system critical frequency falling inside the variable speed range of the process or the added harmonic content of the PWM waveform exciting a system component
- Application related problems related to the controlled acceleration/ deceleration and torque of the motor on VFD power and the building of system pressure/ load.
- The impact the reduction of pump speed has on the down thrust reflected to the pump motor and any minimum thrust requirements of the motor bearings
- Water hammer during shutdown damaging the non-reversing ratchet

Humidity and Non-operational Conditions

The possible build-up of condensation inside the motor due to storage in an uncontrolled environment or non-operational periods in an installation, can lead to an increased rate of premature winding or bearing failures when combined with the stresses associated with PWM waveform characteristics. Moisture and condensation in and on the motor winding over time can provide tracking paths to ground, lower the resistance of the motor winding to ground, and lower the Corona Inception Voltage (CIV) level of the winding.

Proper storage and maintenance guidelines are important to minimize the potential of premature failures. Space heaters or trickle voltage heating methods are the common methods for drying out a winding that has low resistance readings. Damage caused by these factors are not covered by the limited warranty provided for the motor unless appropriate heating methods are properly utilized during non-operational periods and prior to motor start-up.

NEMA^{®†} Application Guide for AC Adjustable Speed Drive Systems: <http://www.nema.org/stds/acadjustable.cfm#download>

*This information applies only to Integral Horsepower (IHP) motors as defined on the Agency Approval page, under UL^{®†} & CSA^{®†} listings where indicated.



† All marks shown within this document are properties of their respective owners.

WARRANTY GUIDELINES FOR INTEGRAL HORSEPOWER (IHP)* MOTORS ON VARIABLE FREQUENCY DRIVES

Warranty Guidelines

The information in the following section refers to the motor and drive application guidelines and limitations for warranty.

Hazardous Location Motors

Use of a variable frequency drive with the motors in this catalog, intended for use in hazardous locations, is only approved for Division 1, Class I, Group D hazardous location motors with a T2B temperature code, with a limitation of 2:1 constant torque or 10:1 variable torque output. No other stock hazardous location motors are inherently suitable for operation with a variable frequency drive. If other requirements are needed, including non-listed Division 2, please contact your Nidec Motor Corporation territory manager to conduct an engineering inquiry.

575 Volt Motors

575 volt motors can be applied on Inverters when output filters are used. Contact the drive manufacturer for filter selection and installation requirements.

Applying INVERTER GRADE[®] Insulated Motors on Variable Frequency Drives (2, 4, 6 pole)

The products within this catalog labeled “Inverter Duty” or “Vector Duty” are considered INVERTER GRADE[®] insulated motors. INVERTER GRADE[®] motors exceed the NEMA[®] MG-1 Part 31 standard. Nidec Motor Corporation provides a three-year limited warranty on all NEMA[®] frame INVERTER GRADE[®] insulated motors and allows long cable runs between the motor and the VFD (limited to 400 feet without output filters). Cable distance can be further limited by hot and humid environments and VFD manufacturers cable limits. These motors may be appropriate for certain severe inverter applications or when the factors relating to the end use application are undefined (such as spares).

Nidec Motor Corporation’s U.S. Motors[®] brand is available in the following INVERTER GRADE[®] insulated motors:

- Inverter Duty NEMA[®] frame motors good for 10:1 Variable Torque & 5:1 Constant Torque, including Vertical Type RUSI
- Inverter Duty motors rated for 10:1 Constant Torque
- ACCU-Torq[®] and Vector Duty Motors with full torque to 0 Speed
- 841 Plus[®] NEMA[®] Frame Motors

Applying Premium Efficient motors (that do not have INVERTER GRADE[®] insulation) on Variable Frequency Drives (2, 4, 6 pole)

Premium efficient motors without INVERTER GRADE insulation meet minimum NEMA[®] MG-1, Section IV, Part 31.4.4.2. These motors can be used with Variable Frequency Drives (with a reduced warranty period) under the following parameters:

- On NEMA[®] frame motors, 10:1 speed rating on variable torque loads & 4:1 speed range on constant torque loads.
- On TITAN[®] frame motors, 10:1 speed rating on variable torque loads.
- On TITAN[®] frame motors, inquiry required for suitability on constant torque loads.

Cable distances are for reference only and can be further limited by hot and

humid environments (refer to Table 1). Refer to specific VFD manufacturers cable limits. Refer to the Motor/ Inverter Compatibility page for special consideration of vertical motor bearings.

Table 1 - Cable Distances			
Maximum Cable Distance VFD to Motor			
Switching Frequency	460 Volt	230 Volt	380 Volt
3 Khz	127 ft	400 ft	218 ft
6 Khz	90 ft	307 ft	154 ft
9 Khz	73 ft	251 ft	126 ft
12 Khz	64 ft	217 ft	109 ft
15 Khz	57 ft	194 ft	98 ft
20 Khz	49 ft	168 ft	85 ft

Warranty Period Clarifications and Exceptions

Standard Energy Efficient Exclusion

Applying Standard & Energy Efficient Motors on Variable Frequency Drives is not recommended. VFD related failures on standard and energy efficient motors will not be covered under warranty.

Vertical Motor Windings

Premium efficient vertical motors without INVERTER GRADE[®] insulation that are installed using the criteria described in this document and applied in the correct applications shall have a warranty while powered by a VFD for 12 months from date of installation or 18 months from date of manufacturing whichever comes first. See limited warranty page for horizontal motor warranty periods.

Bearing Exclusion for Thrust Handling Bearings

Bearings used in premium efficient vertical motors, and all thrust handling bearings, that are powered by VFDs without shaft grounding devices or insulated bearings (when required) will not be covered under any warranty for damages caused from being powered by a VFD. All other bearing failure is covered per NMC’s standard warranty. An electric motor repair shop approved to service U.S. MOTORS[®] brand motors must verify that the cause of the bearing failure was not due to Electrical Discharge Machining.

Medium Voltage and Slow Speed Considerations

Motors that are rated above 700 VAC or that are eight pole and slower require special consideration and installation and are not covered under the warranty guidelines in this document. Motors that are rated above 700VAC have special cable length and voltage differential issues that are specific to the VFD type and manufacture. The motor construction and cost may vary dramatically depending on the VFD topology and construction. Contact your NMC representative with VFD manufacturer name and model type for application and motor construction considerations. Motors that are designed eight pole and slower also require special installation and filters per the drive manufacturer.

*This information applies only to Integral Horsepower (IHP) motors as defined on the Agency Approval page, under UL[®] & CSA[®] listings where indicated.



NIDEC MOTOR CORPORATION

DIVISION OF NIDEC MOTOR CORPORATION

TERMS AND CONDITIONS OF SALE

Nidec Motor Corporation, referred to herein as the "Seller" and the customer or person or entity purchasing goods ("Goods") from Seller is referred to as the "Buyer." These Terms and Conditions, any price list or schedule, quotation, acknowledgment or invoice from Seller relevant to the sale of the Goods and all documents incorporated by specific reference herein or therein, constitute the complete and exclusive statement of the terms of the agreement governing the sale of Goods by Seller to Buyer. Seller's acceptance of Buyer's purchase order is expressly conditional on Buyer's assent to all of Seller's terms and conditions of sale, including terms and conditions that are different from or additional to the terms and conditions of Buyer's purchase order. Buyer's acceptance of or payment for the Goods will manifest Buyer's assent to these Terms and Conditions. Seller reserves the right in its sole discretion to refuse orders.

1. **PRICES:** Prices for Goods, whether specified in Seller's price list or schedule, acknowledgment or written quotation, are subject to change without notice. Such prices shall be adjusted to reflect Seller's prices for Goods as in effect at the time of requested shipment date, and each shipment will be invoiced at such prices. All prices are exclusive of taxes, transportation and insurance, which are to be borne by Buyer.

2. **TAXES:** Any current or future tax or governmental charge (or increase in same) affecting Seller's costs of production, sale, or delivery or shipment, or which Seller is otherwise required to pay or collect in connection with the sale, purchase, delivery, storage, processing, use or consumption of Goods, shall be for Buyer's account and shall be added to the price or billed to Buyer separately, at Seller's election.

3. **TERMS OF PAYMENT:** Unless otherwise specified by Seller, terms are net thirty (30) days from date of Seller's invoice in U.S. currency. Seller shall have the right, among other remedies, either to terminate this agreement or to suspend further performance under this and/or other agreements with Buyer in the event Buyer fails to make any payment when due, which other agreements Buyer and Seller hereby amend accordingly. Buyer shall be liable for all expenses, including attorneys' fees, relating to the collection of past due amounts. If any payment owed to Seller is not paid when due, it shall bear interest, at a rate to be determined by Seller, which shall not exceed the maximum rate permitted by law, from the date on which it is due until it is paid. Should Buyer's financial responsibility become unsatisfactory to Seller, cash payments or security satisfactory to Seller may be required by Seller for future deliveries and for the Goods theretofore delivered. If such cash payment or security is not provided, in addition to Seller's other rights and remedies, Seller may discontinue deliveries. Buyer hereby grants Seller a security interest in all Goods sold to Buyer by Seller, which security interest shall continue until all such Goods are fully paid for in cash, and Buyer, upon Seller's demand, will execute and deliver to Seller such instruments as Seller requests to protect and perfect such security interest.

4. **SHIPMENT AND DELIVERY:** While Seller will use all reasonable commercial efforts to maintain the delivery date(s) acknowledged or quoted by Seller, all shipping dates are approximate and not guaranteed. Seller reserves the right to make partial shipments. Seller, at its option, shall not be bound to tender delivery of any Goods for which Buyer has not provided shipping instructions and other required information. If the shipment of the Goods is postponed or delayed by Buyer for any reason, Buyer agrees to reimburse Seller for any and all storage costs and other additional expenses resulting therefrom. Each shipment is F.C.A. Seller's shipping point (Incoterms 2010). In accordance with the foregoing Incoterm, risk of loss for damage and responsibility for the Goods shall pass from Seller to Buyer for each shipment upon delivery to and receipt by carrier at Seller's shipping point and legal title to the shipped Goods shall transfer to Buyer for each shipment as and when risk of loss with respect to such shipment is transferred to Buyer. Any claims for shortages or damages suffered in transit are the responsibility of Buyer and shall be submitted by Buyer directly to the carrier. Shortages or damages must be identified and signed for at the time of delivery.

5. **LIMITED WARRANTY:** Subject to the limitations of Section 6, Seller warrants that the Goods manufactured by Seller, other than those specifically identified below, will be free from defects in material and workmanship and meet Seller's published specifications at the time of shipment under normal use and regular service and maintenance for a period of twelve (12) months from the date of shipment of the Goods by Seller or eighteen (18) months from the date of manufacture, whichever occurs sooner, unless otherwise specified by Seller in writing. Partial Motors of any kind not fully assembled by Seller shall carry no warranty of any kind, express or implied. Products purchased by Seller from a third party for resale to Buyer ("Resale Products") shall carry only the warranty extended by the original manufacturer. **THE WARRANTY SET FORTH IN THIS SECTION 5 AND THE WARRANTY SET FORTH IN SECTION 7, ARE THE SOLE AND EXCLUSIVE WARRANTIES GIVEN BY SELLER WITH RESPECT TO THE GOODS AND ARE IN LIEU OF AND EXCLUDE ALL OTHER WARRANTIES, EXPRESS OR IMPLIED, ARISING BY OPERATION OF LAW OR OTHERWISE, INCLUDING WITHOUT LIMITATION, MERCHANTABILITY AND FITNESS FOR A PARTICULAR PURPOSE WHETHER OR NOT THE PURPOSE OR USE HAS BEEN DISCLOSED TO SELLER IN SPECIFICATIONS, DRAWINGS OR OTHERWISE, AND WHETHER OR NOT SELLER'S PRODUCTS ARE SPECIFICALLY DESIGNED AND/OR MANUFACTURED BY SELLER FOR BUYER'S USE OR PURPOSE.**

This warranty does not extend to any losses or damages due to misuse, accident, abuse, neglect, normal wear and tear, negligence (other than Seller's), unauthorized modification or alteration, use beyond rated capacity, unsuitable power sources or environmental conditions, improper installation, repair, handling, maintenance or application or any other cause not the fault of Seller. To the extent that Buyer or its agents has supplied specifications, information, representation of operating conditions or other data to Seller in the selection or design of the Goods and the preparation of Seller's quotation, and in the event that actual operating conditions or other conditions differ from those represented by Buyer, any warranties or other provisions contained herein which are affected by such conditions shall be null and void.

If within thirty (30) days after Buyer's discovery of any warranty defects within the warranty period, Buyer notifies Seller thereof in writing, Seller shall, at its option and as Buyer's exclusive remedy, repair, correct or replace or refund the purchase price for that portion of the Goods found by Seller to be defective. Failure by Buyer to give such written notice within the applicable time period shall be deemed an absolute and unconditional waiver of Buyer's claim for such defects. Seller shall have the right to require the Buyer to deliver the Goods to Seller's designated repair center or manufacturing facility. All costs associated with dismantling, reinstallation and transportation to and from Seller's designated repair center or manufacturing facility - and the time and expense of Seller's personnel and representatives for site travel and diagnosis under this warranty shall be borne by the Buyer. Goods repaired or replaced during the warranty period shall be covered by the foregoing warranty for the remainder of the original warranty period or ninety (90) days from the date of shipment, whichever is longer. Buyer assumes all other responsibility for any loss, damage, or injury to persons or property arising out of, connected with, or resulting from the use of Goods, either alone or in combination with other products/components.

Section 5 applies to any entity or person who may buy, acquire or use the Goods, including any entity or person who obtains the Goods from Buyer, and shall be bound by the limitations therein, including Section 6. Buyer agrees to provide such subsequent transferee conspicuous, written notice of the provisions of Sections 5 and 6.

6. **LIMITATION OF REMEDY AND LIABILITY:** **THE SOLE AND EXCLUSIVE REMEDY FOR BREACH OF ANY WARRANTY HEREUNDER (OTHER THAN THE WARRANTY PROVIDED UNDER SECTION 7) SHALL BE LIMITED TO REPAIR, CORRECTION OR REPLACEMENT, OR REFUND OF THE PURCHASE PRICE UNDER SECTION 5.**

SELLER SHALL NOT BE LIABLE FOR DAMAGES CAUSED BY DELAY IN PERFORMANCE AND THE REMEDIES OF BUYER SET FORTH IN THIS AGREEMENT ARE EXCLUSIVE. IN NO EVENT, REGARDLESS OF THE FORM OF THE CLAIM OR CAUSE OF ACTION (WHETHER BASED IN CONTRACT, INFRACTION, NEGLIGENCE, STRICT LIABILITY, OTHER TORT OR OTHERWISE), SHALL SELLER'S LIABILITY TO BUYER AND/OR ITS CUSTOMERS EXCEED THE PRICE PAID BY BUYER FOR THE SPECIFIC GOODS PROVIDED BY SELLER GIVING RISE TO THE CLAIM OR CAUSE OF ACTION. BUYER AGREES THAT IN NO EVENT SHALL SELLER'S LIABILITY TO BUYER AND/OR ITS CUSTOMERS EXTEND TO INCLUDE INCIDENTAL, CONSEQUENTIAL OR PUNITIVE DAMAGES. The term "consequential damages" shall include, but not be limited to, loss of anticipated profits, business interruption, loss of use, revenue, reputation and data, costs incurred, including without limitation, for capital, fuel, power and loss or damage to property or equipment.

It is expressly understood that any technical advice furnished by Seller with respect to the use of the Goods is given without charge, and Seller assumes no obligation or liability for the advice given, or results obtained, all such advice being given and accepted at Buyer's risk.

7. **PATENTS AND COPYRIGHTS:** Subject to the limitations of the second paragraph of Section 6, Seller warrants that the Goods sold, except as are made specifically for Buyer according to Buyer's specifications, do not infringe any valid U.S. patent or copyright in existence as of the date of shipment. This warranty is given upon the condition that Buyer promptly notifies Seller of any claim or suit involving Buyer in which such infringement is alleged and cooperates fully with Seller and permit Seller to control completely the defense, settlement or compromise of any such allegation of infringement. Seller's warranty as to use patents only applies to infringement arising solely out of the inherent operation according to Seller's specifications and instructions (i) of such Goods, or (ii) of any combination of Goods acquired from Seller in a system designed by Seller. In the event such Goods are held to infringe such a U.S. patent or copyright in such suit, and the use of such Goods is enjoined, or in the case of a compromise or settlement by Seller, Seller shall have the right, at its option and expense, to procure for Buyer the right to continue using such Goods, or replace them with non-infringing Goods, or modify same to become non-infringing, or grant Buyer a credit for the depreciated value of such Goods and accept return of them. In the event of the foregoing, Seller may also, at its option, cancel the agreement as to future deliveries of such Goods, without liability. No license or rights in any of Seller's intellectual property associated with the Goods is granted hereby.

In the event that the Goods provided by Seller, as well as any services provided by Seller ("Services"), regardless of whether the Services are at the request or on behalf of Buyer, are part of a project ("Project"), or are performed

alone or are related to the provision of Goods, contain or incorporate any work product, including but not limited to concepts, inventions (patentable or otherwise), works, drawings, designs, information, specifications, customizations, optimizations, improvements, documentation, and programs or software, in each case regardless of whether developed by Seller alone or with others, whether completed or work-in-progress, or whether completed at Buyer's request, Buyer's cost, or as part of a Project performed for Buyer (any and all of the foregoing being "Work Product"), Seller owns all right, title, and interest (including, but not limited to, any patents, copyrights, or other intellectual property rights) in such final Work Product, including any and all intermediate Work Product developed as part or in pursuit of the final Work Product, in connection with, embodied in, or encompassed by any Good, Service, or Project deliverable. Seller makes no transfer or license to Buyer of any right, title, or interest in or to the Work Product or in or to any of Seller's intellectual property or proprietary rights.

8. **EXCUSE OF PERFORMANCE:** Seller shall not be liable for delays in performance or for non-performance due to acts of God; acts of Buyer; war; fire; flood; weather; sabotage; strikes or labor disputes; civil disturbances or riots; governmental requests, restrictions, allocations, laws, regulations, orders or actions; unavailability of or delays in transportation; default of suppliers; or unforeseen circumstances or any events or causes beyond Seller's reasonable control. Deliveries or other performance may be suspended for an appropriate period of time or canceled by Seller upon notice to Buyer in the event of any of the foregoing, but the balance of the agreement shall otherwise remain unaffected as a result of the foregoing. If Seller determines that its ability to supply the total demand for the Goods, or to obtain material used directly or indirectly in the manufacture of the Goods, is hindered, limited or made impracticable due to causes set forth in the preceding paragraph, Seller may allocate its available supply of the Goods or such material (without obligation to acquire other supplies of any such Goods or material) among itself and its purchasers on such basis as Seller determines to be equitable without liability for any failure of performance which may result therefrom.

9. **CANCELLATION:** Buyer may cancel orders only upon reasonable advance written notice and upon payment to Seller of Seller's cancellation charges which include, among other things, all costs and expenses incurred, and, to cover commitments made, by the Seller and a reasonable profit thereon. Seller's determination of such termination charges shall be conclusive.

10. **CHANGES:** Buyer may request changes or additions to the Goods consistent with Seller's specifications and criteria. In the event such changes or additions are accepted by Seller, Seller may revise the price and dates of delivery. Seller reserves the right to change designs and specifications for the Goods without prior notice to Buyer, except with respect to Goods being made to order for Buyer. Seller shall have no obligation to install or make such change in any Goods manufactured prior to the date of such change.

11. **NUCLEAR/MEDICAL:** UNLESS OTHERWISE AGREED IN WRITING BY SELLER: (i) GOODS SOLD HEREUNDER ARE NOT FOR USE IN CONNECTION WITH ANY NUCLEAR, MEDICAL, LIFE-SUPPORT AND RELATED APPLICATIONS. (ii) Buyer accepts Goods with the foregoing understanding, agrees to communicate the same in writing to any subsequent purchasers or users and (iii) Buyer agrees to defend, indemnify and hold harmless Seller from any claims, losses, suits, judgments and damages, including incidental and consequential damages, arising from such use, whether the cause of action be based in tort, contract or otherwise, including allegations that the Seller's liability is based on negligence or strict liability.

12. **ASSIGNMENT:** Buyer shall not assign its rights or delegate its duties hereunder or any interest herein without the prior written consent of Seller, and any such assignment, without such consent, shall be void.

13. **QUANTITY:** Buyer agrees to accept overruns of up to ten percent (10%) of the order on "made-to-order" goods, including parts. Any such additional items shall be priced at the price per item charged for the specific quantity ordered.

14. **REPLACEMENT / SERVICE GOODS:** Upon the cancellation or fulfillment of this order, Seller will have no obligation to sell and Buyer will have no obligation to purchase the Goods sold hereunder, including, but not limited to, the supply of replacement parts for Goods or Goods for Buyer's consumer service division. Seller is not obligated to sell Buyer or its consumer service divisions Goods: (i) for any fixed period of time after production of the Goods supplied hereunder ceases or after the last date of shipment made under this order; or (ii) at any pre-established price to fulfill Buyer's or its consumer service divisions requirements during or after production of the Goods ceases or after the last date of shipment under this order. Seller shall have the absolute right to revise the price of Goods and the terms of sale and to modify or discontinue the sale of the Goods, and such action shall not form the basis of any claim by Buyer against Seller.

15. **TOOLING:** Tool, die, and pattern charges, if any, are in addition to the price of the Goods and are due and payable upon completion of the tooling. All such tools, dies and patterns shall be and remain the property of Seller. Charges for tools, dies, and patterns do not convey to Buyer, title, ownership interest in, or rights to possession or removal, or prevent their use by Seller for other purchasers, except as otherwise expressly provided by Seller and Buyer in writing with reference to this provision.

16. **INSPECTION/TESTING:** Buyer, at its option and expense, may inspect and observe the testing by Seller of the Goods for compliance with Seller's standard test procedures prior to shipment, which inspection and testing shall be conducted at Seller's plant at such reasonable time as is specified by Seller. Any rejection of the Goods must be made promptly by Buyer before shipment. Tests shall be deemed to be satisfactorily completed and the test fully met when the Goods meet Seller's criteria for such procedures.

17. **DRAWINGS:** Seller's prints and drawings (including without limitation, the underlying technology) furnished by Seller to Buyer in connection with this agreement are the property of Seller and Seller retains all rights, including without limitation, exclusive rights of use, licensing and sale. Possession of such prints or drawings does not convey to Buyer any rights or license, and Buyer shall return all copies (in whatever medium) of such prints or drawings to Seller immediately upon request therefor.

18. **EXPORT/IMPORT:** Buyer agrees that all applicable import and export control laws, regulations, orders and requirements, including without limitation those of the United States and the European Union, and the jurisdictions in which the Seller and Buyer are established or from which Goods may be supplied, will apply to their receipt and use. In no event shall Buyer use, transfer, release, import, export, Goods in violation of such applicable laws, regulations, orders or requirements.

19. **INSURANCE:** Seller shall carry adequate product liability and commercial general liability insurance. Seller shall, upon written request from Buyer, furnish Buyer with certificates of insurance confirming the existence of such insurance. Seller does not waive its, or its insurers', rights of subrogation.

20. **GENERAL PROVISIONS:** These terms and conditions supersede all other communications, negotiations and prior oral or written statements regarding the subject matter of these terms and conditions. No change, modification, rescission, discharge, abandonment, or waiver of these terms and conditions shall be binding upon the Seller unless made in writing and signed on its behalf by a duly authorized representative of Seller. No conditions, usage of trade, course of dealing or performance, understanding or agreement purporting to modify, vary, explain, or supplement these terms and conditions shall be binding unless hereafter made in writing and signed by the party to be bound, and no modification or additional terms shall be applicable to this agreement by Seller's receipt, acknowledgment, or acceptance of purchase orders, shipping instruction forms, or other documentation containing terms at variance with or in addition to those set forth herein. Any such modifications or additional terms are specifically rejected and deemed a material alteration hereof. If this document shall be deemed an acceptance of a prior offer by Buyer, such acceptance is expressly conditional upon Buyer's assent to any additional or different terms set forth herein. No waiver by either party with respect to any breach or default or of any right or remedy, and no course of dealing, shall be deemed to constitute a continuing waiver of any other breach or default or of any other right or remedy, unless such waiver be expressed in writing and signed by the party to be bound. All typographical or clerical errors made by Seller in any quotation, acknowledgment or publication are subject to correction.

The validity, performance, and all other matters relating to the interpretation and effect of this agreement shall be governed by the law of the state of Missouri without regard to its conflicts of laws principles. Buyer and Seller agree that the proper venue for all actions arising in connection herewith shall be only in Missouri and the parties agree to submit to such jurisdiction. No action, regardless of form, arising out of transactions relating to this contract, may be brought by either party more than two (2) years after the cause of action has accrued. The U.N. Convention on Contracts for the International Sales of Goods shall not apply to this agreement.



INTRODUCTION

This pricing guide provides the user with Nidec Motor Corporation's product capabilities for vertical motors. The U.S. Motors® brand is the most used and specified motor in our industry today.

Quality

We set rigid standards for ourselves and our suppliers with constant field monitoring to provide you with the assurance of the utmost product reliability.

Experience

Since the 1922 introduction of the patented HOLLOSHAFT® motor, we have been producing vertical high-thrust motors for the pumping industry ensuring your specific needs are met.

Service

From quotation to field installation, our service team will provide you with all the necessary support.

Innovation

We continually add product value by providing the latest engineering and manufacturing designs to provide quality standards that meet your current application demands.

Our vertical motors are offered in solid shaft and HOLLOSHAFT® configurations.

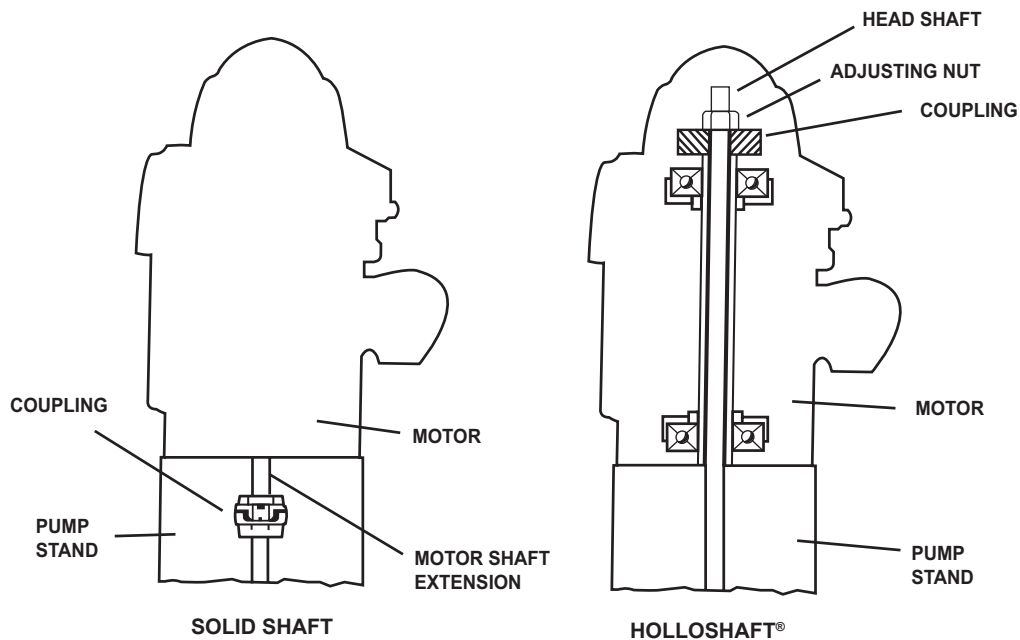

OUR MOTORS

Introduced in 1922, U.S. Motors® brand vertical HOLLOWSHAFT® motor was developed to meet the specific needs of the vertical turbine pump industry. With the pump shaft extended through the hollow shaft, adjustment can be made by a nut threaded on the shaft at the accessible top portion of the motor. This adjustment is required to lift the impellers and give a running clearance with the pump casing. The stretch of several hundred feet of shafting may require a lift at the top of the well, and the impeller at the bottom must be positioned within a fraction of an inch.

The drive coupling also provides a solution to the problem of power reversal. The pump shaft is usually composed of many lengths joined by screw thread couplings. A power reversal would unscrew the joints, causing the shaft to lengthen and buckle or break. The self-release coupling lifts out of its engagement position and prevents this problem.

In addition to normal induction motor classifications, the vertical motor is classified by thrust. Thrust is the sum of the axial forces of the weight of the pump and lineshaft and the dynamic forces of the pump to lift the liquid to the surface. NEMA does not specifically define thrust ratings for motors, but each manufacturer will define thrust ratings for their product rating. 100 percent high thrust, 175 percent high thrust and 300 percent high thrust are common.

Normal-thrust motors are used in general applications where there is very low or no external thrust applied to the motor bearing. It is often a footless horizontal motor with a “P” flange (the “P” flange mounting for the vertical motor).

In-line thrust, sometime called medium thrust, is a definite purpose motor. The pump impellers are mounted directly on the motor shaft. Since the pump impeller performance depends on close tolerance with the pump housing, the motor shaft and flange round-out tolerances must also be tighter than normal. The thrust bearing is usually located at the bottom rather than the top, as in high-thrust construction. This keeps the motor rotor’s thermal growth from affecting the impeller clearances.

Enclosures provide protection against specific environmental conditions. Our motors are available with Weather Protected I, Weather Protected II, Totally Enclosed and Hazardous Location enclosures.



MOTOR VARIETIES

Weather Protected Type I (WPI)

Open motors are constructed to minimize the entrance of rain, snow and airborne particles. Our enclosures exceed NEMA^{®†} requirements through built-in extra protection for rugged outdoor applications. The ventilation system, available in all motor sizes, is designed to provide optimum cooling to the thrust bearing and electrical components.

HOLLOSHAFT[®] motors *page P-1*
Solid Shaft motors *page P-31*
WPI
3–5000 Horsepower

Weather Protected Type II (WP II)

This NEMA^{®†} enclosure offers maximum protection against hostile outdoor atmospheres. The special ventilation system minimizes the entrance of high velocity air, moisture and airborne particles into the cooling passages of the motor.

HOLLOSHAFT[®] motors
Solid Shaft motors
WP II
150–5000 Horsepower

Totally Enclosed and Hazardous Location (TEFC/HAZARDOUS LOCATION)

Totally enclosed and Hazardous Location models are available with our non-sparking, non-reverse ratchet design for severe atmospheres where destructive dusts, vapors and other harmful substances are found. When Underwriters Laboratories' approval is necessary, our Hazardous Location design is the answer. They are available in motor sizes through 700 horsepower.

HOLLOSHAFT[®] motors *page P-22*
Solid Shaft motors *page P-53*
TEFC 3 – 2000 Horsepower
HAZARDOUS LOCATION 3-700 Horsepower

CORRO-DUTY[®] cast-iron construction is also available with external corrosion-resistant paint and hardware for extremely harsh environments.



MOTOR VARIETIES (continued)

Normal Thrust

Normal-thrust motors are designed for use with pumps and other general industrial applications. Axial thrust is normally very low, while radial loads are generally higher. The thrust bearing is locked for thrust in either direction.

Available in Open and Enclosed Designs

*Solid Shaft motors
1–800 Horsepower*

page P-71

In-line Pump Motor

The in-line pump motor is specially designed and manufactured for long life in applications involving radial load due to suction variation and changes in pump capacity.

Available in Enclosed and Hazardous Location Designs

*Solid Shaft motors
3–200 Horsepower*

page P-65

Vertical Aerator Motor

A special CORRO-DUTY® treatment makes our motors unsurpassed for reliability in hostile environments, particularly those related to waste aeration. For severe applications, the CORRO-DUTY® vertical aerator to the municipal, pulp and paper, and petroleum and chemical industries, among others.

*Solid Shaft motors
TEFC
5–200 Horsepower*

page P-68



CLASSIFICATIONS

For your assistance, below is a comparison of environmental protection classifications of IEC 34-5 and NEMA MG 1 - 1.25 and 1.26. Because direct correlation is not always possible, the following represents the more common interpretations.

NEMA	IEC
<p style="text-align: center;">OPEN MACHINES</p> <p>An open machine is one having ventilating openings which permit passage of external cooling air over and around the windings of the machine. The term “open machine,” when applied to large apparatus without qualification, designates the machine having no restriction to ventilation other than that necessitated by mechanical construction.</p> <p><i>Reference only. Nidec Motor Corporation does not provide for P-base verticals</i></p>	
<p style="text-align: center;">DRIP PROOF MACHINE</p> <p>A drip proof machine is an open machine in which the ventilating openings are so constructed that successful operation is not interfered with when drops of liquid or solid particles strike or enter the enclosure at any angle from 0 degrees to 15 degrees downward from the vertical.</p> <p><i>Reference only. Nidec Motor Corporation does not provide for P-base verticals</i></p>	<p style="text-align: center;">IP 21</p> <p>Protection against accidental or inadvertent contact with live and moving parts inside the enclosure by a large surface of the human body (for example, a hand) but no protection against deliberate access to such parts.</p> <p>Protection against ingress of large solid foreign bodies (diameter greater than 50 mm).</p> <p>Machine protected against drops of water falling up to 15 percent from the vertical.</p>
<p style="text-align: center;">DRIP PROOF GUARDED</p> <p>A guarded machine is an open machine in which all openings giving direct access to live metal or rotating parts (except smooth rotating surfaces) are limited in size by the structural parts or by screens, baffles, grilles, expanded metal or other means to prevent accidental contact with hazardous parts. Openings giving direct access to such live or rotating parts shall not permit the passage of a 3/4-inch diameter cylindrical rod.</p> <p><i>Reference only. Nidec Motor Corporation does not provide for P-base verticals</i></p>	<p style="text-align: center;">IP 22</p> <p>IP 22 protection against contact by finger with live or moving parts inside the enclosure.</p> <p>Protection against ingress of small, solid foreign bodies (diameter greater than 50 mm).</p> <p>Machine protected against drops of water falling up to 15 degrees from the vertical.</p>



CLASSIFICATIONS (continued)

NEMA	IEC
<p style="text-align: center;">Weather Protected Machines</p> <p>A Weather Protected Type I machine is a guarded machine with ventilating passages constructed to minimize the entrance of rain, snow and airborne particles to the electric parts. Ventilating openings are constructed to prevent the passage of a cylindrical rod 3/4 diameter.</p> <p><i>Standard on P-base</i></p> <p>A Weather Protected Type II machine has its ventilating passages at both intake and discharge so arranged that high-velocity air and airborne particles blown into the machine by storms or high winds can be discharged without entering the internal ventilating passages leading directly to the electric parts of the machine itself. The normal path of ventilating air which enters the electric parts of the machine shall be so arranged by baffling or separate housings as to provide at least three abrupt changes in direction, none of which shall be less than 90 degrees. In addition, an area of low velocity not exceeding 600 feet per minute shall be provided in the intake air path to minimize the possibility of moisture or dirt being carried into the electric parts of the machine.</p>	<p style="text-align: center;">IP 23</p> <p>Machine protected against spraying water. A machine is weather protected when its design reduces the ingress of rain, snow and airborne particles, under specified conditions, to an amount consistent with correct operation.</p> <p style="text-align: center;">IPW 23</p> <p>Protection against contact by finger with live or moving parts inside the enclosure. Protection against ingress of small, solid foreign bodies (diameter greater than 12mm). Water falling as a spray at an angle equal to or smaller than 60° with respect to the vertical shall have no harmful effect.*</p> <p style="text-align: center;">IPW 24</p> <p>Protection against contact by finger or live or moving parts inside the enclosure.* Protection against ingress of small solid, foreign bodies (diameter greater than 12mm). Water splashed against the machine from any direction shall have no harmful effect.</p>
<p style="text-align: center;">Totally Enclosed Machines</p> <p>A Totally Enclosed machine is enclosed to prevent the free exchange of air between the inside and outside of the case, but not sufficiently enclosed to be termed airtight.</p> <p>A Totally Enclosed non-ventilated machine is a frame surface cooled totally enclosed machine only equipped for cooling by free convection.</p> <p>A Totally Enclosed fan-cooled machine is a frame-surface cooled totally enclosed machine equipped for self-exterior cooling by means of a fan or fans integral with the machine but external to the enclosing parts.</p>	

*For machines cooled by an external cooling fan, the fan shall be protected to prevent contact with the blades or spokes of the fan with a standard test finger. However, at the outlet of the fan, the test finger is not inserted past the 50mm diameter guard.



† All marks shown within this document are properties of their respective owners.

CLASSIFICATIONS (continued)

NEMA	IEC
<p>Totally Enclosed Fan Cooled Guarded</p> <p>A Totally Enclosed Fan Cooled Guarded machine is a totally enclosed fan cooled machine in which all openings giving direct access to the fan are limited in size by the design of the structural parts or screens, grilles, expanded metal, etc., to prevent accidental contact with the fan. Such openings shall not permit the passage of a cylindrical rod .75 inch in diameter and a probe shall not contact the blades, spokes or other irregular fan surfaces.</p> <p><i>Standard WP11 with filters meets the intent of IP-44</i></p>	<p>IP 44</p> <p>Protection against contact with live or moving parts inside the enclosure by tools, wires or such objects of thickness greater than 1mm.</p> <p>Protection against ingress of small, solid foreign bodies (diameter greater than 1mm), excluding ventilation openings (intake and discharge of external fans) and the drain hole of enclosed machine, which may have degree of 2 protection.</p> <p>Water splashed against the machine from any direction shall have no harmful effect.</p>
<p>WPI and WP11 on TITAN® frames may be utilized in place of IP-54. In extremely dusty areas WP11 motors with filters should be used. On frames 440 or smaller, TEFC is an acceptable enclosure.</p>	<p>IP 54</p> <p>Complete protection against contact with live or moving parts inside the enclosure.*</p> <p>Protection against harmful deposits of dust. The ingress of dust is not totally prevented, but dust cannot enter in an amount sufficient to interfere with satisfactory operation of the machine.</p> <p>Water splashed against the motor from any direction shall have no harmful effects.</p>
<p>Totally Enclosed Fan Cooled Waterproof Machine</p> <p>A waterproof machine is a totally enclosed machine constructed to exclude water applied in the form of a stream from a hose, except that leakage may occur around the shaft, provided it is prevented from entering the reservoir and a provision is made for automatically draining the machine. The means for automatic draining may be a check valve or a tapped hole at the lowest part of the frame which will serve for application of a drain pipe.</p>	<p>IP 55</p> <p>Complete protection against contact with live or moving parts inside the enclosure.*</p> <p>Protection against harmful deposits of dust. The ingress of dust is not totally prevented, but dust cannot enter in an amount sufficient to interfere with satisfactory operation of the machine.</p> <p>Water projected by a nozzle against the machine from any direction shall have no harmful effect.</p>

*For machines cooled by an external cooling fan, the fan shall be protected to prevent contact with the blades or spokes of the fan with a standard test finger. However, at the outlet of the fan, the test finger is not inserted past the 50mm diameter guard.



TYPE DESIGNATIONS

U.S. MOTORS® type codes for vertical motors do have meaning -- the first letter designates the enclosures:

R = NEMA[†] and TITAN® WPI T = NEMA[†] TEFC L = NEMA[†] Hazardous Location U.L. Listed
 H = TITAN® WPI, WPII A = NEMA[†] WPI E = TITAN® Hazardous Location U.L. Listed
 J = TITAN® TEFC N = NEMA[†] Hazardous

The second letter designates the type of shaft, V for solid shaft, U for hollow shaft. The third letter designates special features, such as:

E = Premium Efficient (TITAN®) E = Energy Efficient (NEMA[†]) C= CORRO-DUTY®
 R = Single Phase Cap Run S = Premium Efficient (NEMA[†]) I = VFD/Inverter Duty

The fourth letter designates the thrust, as follows:

Blank = Solid Shaft Normal Thrust and Hollow Shaft High Thrust
 -3 = Medium Thrust (JV-3) -4 = High Thrust
 -9 = In-Line (Medium) -5 = High Thrust with Plate Bearings

Standard combinations are as follows:

ENCLOSURE	HIGH THRUST			
	NEMA		TITAN	
	HOLLOW SHAFT	SOLID SHAFT	HOLLOW SHAFT	SOLID SHAFT
OPEN OPEN - Energy Efficient OPEN - Premium Efficient OPEN - Inverter	AU/RU AUE/RUE AUS/RUS AUSI/RUSI	AV-4/RV-4 AVE-4/RVE-4 AVS-4/RVS-4 AVSI-4/RVSI-4	HU/RU --- HUE/RUS/RUE HUEI/RUEI RUSI	HV-4/RV-4 --- HVE-4/RVS-4/RVE-4 HVEI-4/RVEI-4 RVSI-4
ENCLOSED ENCLOSED - Energy Efficient ENCLOSED - Premium Efficient ENCLOSED - Inverter	TU TUE TUS TUI	TV-4 TVE-4 TVS-4 TVI-4	JU --- JUE JUEI	JV-4 --- JVE-4 JVI-4
U.L. Listed Division 1 ◊ U.L. Listed Division 1 - Energy Efficient U.L. Listed Division 1 - Premium Efficient	LU LUE LUS	LV-4 LVE-4 LVS-4	EU --- EUE	EV-4 --- EVE-4
U.L. Listed DIVISION 2 U.L. Listed DIVISION 2 - Energy Efficient U.L. Listed DIVISION 2 - Premium Efficient	NU NUE ---	NV-4 NVE-4 ---	--- --- ---	--- NVE-4 ---

◊ Inverter-duty Hazardous Location motors must be referred to engineering for approval.

In this section, NEMA denotes NEMA[†] standard motors, and Titan denotes TITAN® large motors.



† All marks shown within this document are properties of their respective owners.

TYPE DESIGNATIONS (continued)

Standard combinations are as follows:

NORMAL THRUST SOLID SHAFT

ENCLOSURE	NEMA	TITAN
OPEN OPEN - Energy Efficient OPEN - Premium Efficient OPEN - Inverter	AV/RV AVE/RVE RVS AVSI/RVSI	HV/RV --- HVE/RVE HVEI/RVEI
ENCLOSED ENCLOSED - Energy Efficient ENCLOSED - Premium Efficient ENCLOSED - Inverter	TV, CTV TVE TVS TVI	JV --- JVE JVEI
U.L. Listed Division 1 U.L. Listed Division 1 - Energy Efficient U.L. Listed Division 1 - Premium Efficient	LV LVE LVS	EV --- EVE
U.L. Listed DIVISION 2 U.L. Listed DIVISION 2 - Energy Efficient U.L. Listed DIVISION 2 - Premium Efficient	NV NVE ---	--- --- ---

IN-LINE/AERATOR

ENCLOSURE	NEMA	TITAN
ENCLOSED ENCLOSED - Energy Efficient ENCLOSED - Premium Efficient U.L. Listed Division 1 U.L. Listed Division 1 - Energy Efficient U.L. Listed Division 1 - Premium Efficient	TV-9 TVE-9 TVS-9 LV-9 LVE-9 LVS-9	--- --- --- --- --- ---

◇ In this section, NEMA denotes NEMA^{®†} standard motors, and Titan denotes TITAN[®] large motors.



CONSTRUCTION FEATURES

BEARING CAPS: All vertical motors are furnished with lower bearing caps constructed of aluminum or cast iron.

STANDARD BEARING LUBRICATION:

FRAME	TYPE	UPPER BEARING	LOWER BEARING	THRUST CAPACITY
180-280	AU, AV-4	GREASE	GREASE**	HIGH
180-440	AV, TV, LV	GREASE	GREASE**	NORMAL
	AV-9, TV-9, LV-9			MEDIUM
320-440	RV	GREASE	GREASE**	NORMAL
	RV-9			MEDIUM
	RU, RV-4	OIL	GREASE	HIGH
180-360	TU, TV-4 LU, LV-4	GREASE	GREASE**	HIGH
400-440		OIL	GREASE	HIGH
449, 2P	JV	GREASE	GREASE	NORMAL
	JV-4	OIL	GREASE	HIGH
449, 4P & SLOWER	RU, RV-4	OIL	GREASE	HIGH
	RV	GREASE	GREASE	NORMAL
	JV	GREASE	GREASE	NORMAL
	JV-3	GREASE	GREASE	MEDIUM
	JU, JV-4	OIL	GREASE	HIGH
5000	RV	GREASE	GREASE	NORMAL
	RU, RV-4	OIL	GREASE	HIGH
	EV, JV	GREASE	GREASE	NORMAL
	JU, JV-4 EU, EV-4	OIL	OIL	HIGH
5800	EV, JV+	GREASE	GREASE	NORMAL
	JU, JV-4 EU, EV-4	OIL	OIL	HIGH
5813	RV	GREASE	GREASE	NORMAL
	RU, RV-4	OIL	OIL	HIGH
6800	RV	OIL	OIL	NORMAL
	RU, RV-4 JV-4 JU	OIL	OIL	HIGH
	RV	GREASE	GREASE	NORMAL
8000	RV	GREASE	GREASE	NORMAL
	RU, RV-4	OIL	OIL	HIGH
9600	RV	GREASE	GREASE	NORMAL
	RU, RV-4	OIL	OIL	HIGH

** LOWER BEARING IS THRUST BEARING

+ 2 pole designs will be oil – oil design

BRACKETS: NEMA^{®†} frame motors: Both end brackets are cast iron except for the following motors:
 Type AV; Upper bracket on 180 & 210 frames is aluminum.
 Type TV & TV9; Upper bracket on 180 - 280 frames is aluminum.*
 Type TU & TV-4; Upper bracket on 250 & 280 frames is aluminum.*

*Note: CORRO-DUTY[®] option has cast-iron brackets.



† All marks shown within this document are properties of their respective owners.

CONSTRUCTION FEATURES (continued)

BRACKETS (continued)

TITAN[®] frame motors: Cast iron on 449 - 5800 frames.
 Cast iron or fabricated steel on 6800 - 8000 frames.
 Fabricated steel on 9600 frames.

CANOPY CAP: Constructed of plastic, steel, aluminum, fiberglass or cast iron depending on exact frame and type

CORRO-DUTY[®] motors have a cast iron canopy cap.

(1) ENCLOSURES:

NEMA^{®†} frame motors: 180 through 447

Type:	AV, AU, AV4, RV, RU, RV4	=	WPI
	TV, CTV, TU, TV4, TV9	=	TEFC
	LV, LU, LV4, LV9	=	HAZARDOUS - DIVISION 1(U.L. Listed)
	NV, NU, NV4, NV9	=	HAZARDOUS - DIVISION 2 (U.L. Listed)

TITAN[®] frame motors: 449 and larger

Type:	HV, HU, HV4, RV, RU, RV4	=	WPI (WPII option available)
	JV, JU, JV4	=	TEFC
	EV, EU, EV4	=	HAZARDOUS - DIVISION 1(U.L. Listed)

FAN COVER (TEFC):

Constructed of plastic, steel, aluminum or cast iron depending on exact frame and type.

CORRO-DUTY[®] NEMA frame motors have cast iron fan cover. CORRO-DUTY[®] and TITAN[®] motors (449 frame & up) have either steel or cast iron fan covers.

(2) FRAME MATERIAL:

NEMA^{®†} frame motors: 180 through 447

Type:	AV, AU, AV4,	=	Aluminum
	RV, RU, RV4, CTV	=	Cast iron
	TV, TU, TV4, TV9	=	Aluminum (180 - 280 frames)*
		=	Cast iron (320 - 440 frames)
	LV, LU, LV4, LV9	=	Cast iron
	NV, NU, NV4, NV9	=	Cast iron

*Note: CORRO-DUTY[®] option has cast-iron frame



CONSTRUCTION FEATURES (continued)

TYPICAL ENCLOSURE MATERIAL

TITAN[®] Motor Frames

FRAME	<u>WPI</u> HU RU HV RV HV4 RV4	<u>WPII</u> HU RU HV RV HV4 RV4	<u>TEFC</u> JU JV JV4	<u>XP</u> EU EV EV4
449	CAST IRON	CAST IRON	CAST IRON	---
5008	CAST IRON	CAST IRON	CAST IRON	CAST IRON
5012	CAST IRON	CAST IRON	---	---
5807	---	---	CAST IRON	CAST IRON
5809	---	---	CAST IRON	CAST IRON
5811	---	---	CAST IRON	CAST IRON
5812	---	---	CAST IRON	CAST IRON
5813	CAST IRON	CAST IRON	---	---
6812	---	---	CAST IRON	---
6808, 6810	FAB STEEL	FAB STEEL	---	---
6813	CAST IRON	CAST IRON	---	---
8000	FAB STEEL	FAB STEEL	---	---
9600	FAB STEEL	FAB STEEL	---	---



† All marks shown within this document are properties of their respective owners.

CONSTRUCTION FEATURES (continued)

INSULATION: Class F (NEMA^{®†} frame WPI stock motors are nameplated for Class B temperature rise).

Low voltage motors (600 volts and less) 600 HP and lower are random wound, Class F insulation.

Low voltage motors 601 HP and up and all medium voltage motors (above 600 Volts) are form wound, Class F insulation. Some slow speed motors with lower HP than 601 may require form wound designs.

OUTLET BOX: NEMA^{®†} frame motors:

Aluminum or steel. CORRO-DUTY[®] option has cast-iron outlet box.

TITAN[®] large frame motors:

- (1) Obtain "AF" dimension from dimension print of product in question.
- (2) Find matching "AF" in the "Conduit Box" section of the Accessories and Modifications.
- (3) Read across to "Type Construction" column.
- (4) Cast iron is standard on hazardous location.
- (5) Cast iron or steel is standard on CORRO-DUTY[®] motors.

ROTOR BARS: Aluminum. Copper bar option available on TITAN[®] large frame motors.

SHAFTS: AISI 1045 steel. Optional high-tensile steel.

STANDARD SERVICE FACTOR: WPI & WPII = 1.15, 1.00 on medium voltage, 12-pole and slower
TEFC & Hazardous Location - 1.0

THRUST BEARING LOCATION:

TYPE	THRUST BEARING
NEMA^{®†} FRAME MOTORS NORMAL THRUST: AV, RV, LV, NV TV, CTV, CEV IN-LINE: TV9, LV9, NV9 HIGH-THRUST: AU TV-4, TU, LU, NU (180-360 FRAME) RU, RV-4 TV-4, TU, LU, LV-4, NU, NV-4 (400 - 440 FRAME)	LOWER BEARING UPPER BEARING LOWER BEARING LOWER BEARING LOWER BEARING UPPER BEARING UPPER BEARING
TITAN[®] LARGE FRAME MOTORS NORMAL THRUST 5000 AND 5800 TYPES EV, JV ALL OTHERS	LOWER BEARING UPPER BEARING



† All marks shown within this document are properties of their respective owners.

PRICE GUIDE

This pricing guide is intended to provide the user with Nidec Motor Corporation product capabilities for vertical motors. Because of the special nature of this product, the following outlines the basic requirements for processing an order.

- A) HP, speed
- B) Enclosure type (if hazardous location - details class, group and temperature code)
- C) Altitude and ambient
- D) Service factor
- E) Insulation class
 - temperature rise @ 1.0 or 1.15
- F) Pump thrust
 - @ Design – Rating life requirement
 - @ Shut off
 - @ Up-thrust conditions, continuous or momentary
- G) Base diameter
- H) If HOLLOSHAFT® – head shaft diameter
- I) Inverter duty – type of inverter and speed range
- J) Voltage and frequency
- K) If Solid Shaft – details of shaft requirements
- L) Special accessories – i.e. space heaters or RTDs

For further details or questions regarding our capabilities, please contact your distributor or nearest Nidec Motor Corporation regional office.

Minimum Order Quantities

The following minimum order quantities apply to Modifiable NEMA[†] Vertical Motors. Quantity is per rating.

- 56 / 140 Frames = Q-15
- 180 / 210 Frames = Q-5
- 250 Frame & Up = No Minimum

Orders with smaller quantities are available with a \$350 per order Set Up Charge (adder is divided across the order quantity).

- Example: Q-4 140 Frame Motors
- Set Up Charge = $\$350/4 = \87.50 Per Motor



EVERY DROP COUNTS.

ACCU-Series™ Pump Panels for Agricultural Irrigation
U.S. MOTORS® brand inverter duty solutions. One company. One point of responsibility. Motor match drive warranty.



**We Build More Than Just Motors.
We Build Solutions.**

Nidec

NIDEC MOTOR CORPORATION



To purchase a pump panel, please contact your local certified pump panel re-seller. Interested in becoming a certified reseller? Please contact Nidec.

Complete Solutions. Rapid Delivery.

Nidec Motor Corporation provides rapid delivery of the most popular 30HP to 200HP panels from stock with the ability to quickly configure panels with pre-engineered options.

Standard ACCU-Series Pump Panel Features

- NEMA 3R enclosure
- UL 508 listed
- 50 degrees C rated operation
- 460V, 3-Phase
- 30 to 200 horsepower catalog stock
- Ventilating fans with mesh filters
- Circuit breaker disconnect
- HOA switch
- Door mounted speed potentiometer
- Pilot light and door lock
- Line reactor

460V - 3 Phase Input				
Drive Panel		Vertical Motor Match		
Amps	Catalog Number	HP	FLA	Catalog Number
36	AGP003643A000000	30	35	HO30V2BLF
47	AGP004743A000000	40	45	HO40V2BLG HO40V2BLF
59	AGP005943A000000	50	57	HO50V2BLG
69	AGP006943A000000	60	68	HO60V2SLG
112	AGP011243A000000	75	87	HO75V2SLG
140	AGP014043A000000	100	114 115	HO100V2SLG HO100V2SLGX
162	AGP016243A000000	125	142 143	HO125V2SLG HO125V2SLGX
189	AGP018943A000000	150	164 165	HO150V2SLG HO150V2SLGX
270	AGP027043A000000	200	222	HO200V2SLH HO200V2SLHX
335	AGP033543B000000	250	297	HO250V2SLH HO250V2SLHX
370	AGP037043B000000	300	355 357	HO300V2SLH HO300V2SLHX
460	AGP046043B000000	350	409	HO350V2SLH
		400	455	HO400V2SLH HO400V2SLHX
580	AGP058043B000000	450	510 512	HO450V2SLH HO450V2SLHX
		500	568	HO500V2SLH HO500V2SLHX
680	AGP06843B000000	600	676	HO600V2SLJX

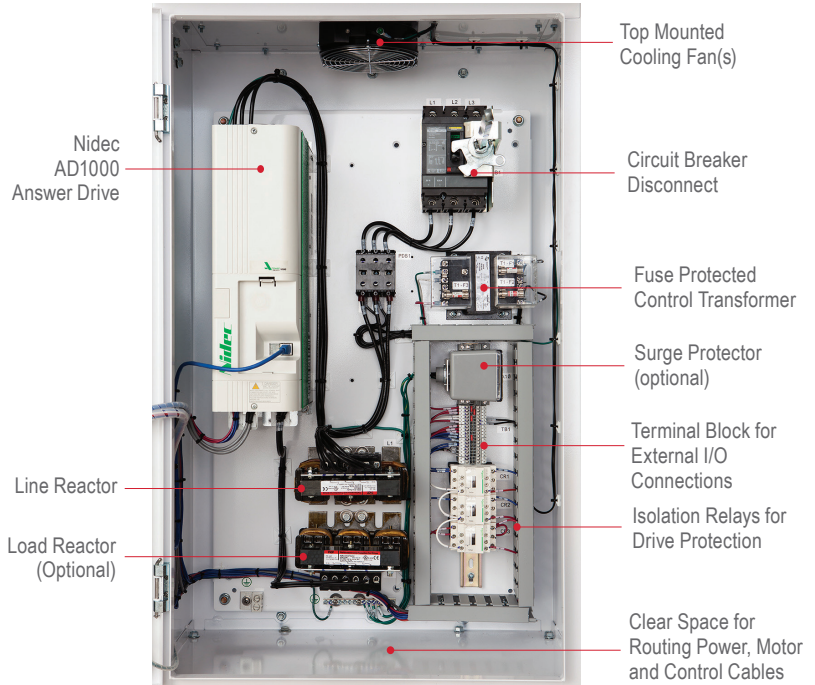

30 HP to 200 HP panels available from stock. Panels 250 HP to 600 HP are built to order. Additional options (e.g. system bypass, indicators) available by request.

Motor Match Drive Warranty

The ACCU-Series™ Pump Panel standard warranty covers all panel components for 12/18 months from date of installation/manufacturing. Our Motor Match Drive Warranty extends the length of the drive warranty to match the standard warranty of the new, unused, U.S. MOTORS® brand inverter duty motor it's driving. That means up to 36 months from the date of installation at no additional charge. Only product registration is required.



† All marks shown within this document are properties of their respective owners.

Nidec Motor Corporation, 2018; All Rights Reserved. U.S. MOTORS® is a registered trademark of Nidec Motor Corporation. Nidec Motor Corporation trademarks followed by the ® symbol are registered with the U.S. Patent and Trademark Office.

8050 W. Florissant Avenue | St. Louis, MO 63136
Phone: 888-637-7333 | Fax: 866-422-7758

Three Phase Modifiable Motors
Vertical HOLLOSHAFT®
High Thrust - "P" Base
Weather Protected Type I (WPI)
2 Pole, 3600 RPM



APPLICATIONS:

For use on Turbine, Mix Flow and Propeller Pumps

FEATURES:

- * Class F Insulation, Class B Rise at Full Load (Sine Wave Power)
- * 1.15 Service Factor (Sine Wave Power)
- * Maximum 40 Deg. C. Ambient, 3,300 Feet Altitude
- * NEMA Design "B"
- * 3 Phase 60 Hz

460 or 575 Volt

HP	Down Thrust (lbs) (#)	Standard Efficient			Energy Efficient			Premium Efficient			NRR List Adder	Disc. Sym
		Frame	SRC List	Type	Frame	SRC List	Type	Frame	SRC List	Type		
20	2600	254TP	\$3,484	AU	254TP	\$3,971	AUE	254TP	\$4,368	AUS	\$347	7VM
25	2600	256TP	\$3,681	AU	256TP	\$4,262	AUE	256TP	\$4,698	AUS	\$371	7VM
30	2600	284TP	\$4,033	AU	284TP	\$4,588	AUE	284TP	\$5,228	AUS	\$399	7VM
40	2600	286TP	\$5,272	AU	286TP	\$5,665	AUE	286TP	\$6,362	AUS**	\$526	7VM
50	4600	324TP	\$6,052	RU	324TP	\$6,822	RUE	324TP	\$7,181	RUS	\$535	7VM
60	4600	326TP	\$7,221	RU	326TP	\$7,785	RUE	326TP	\$8,195	RUS	\$638	7VM
75	4500	364TP	\$8,585	RU	364TP	\$9,036	RUE	364TP	\$9,512	RUS	\$793	7VM
100	4500	365TP	\$12,174	RU	365TP	\$12,733	RUE	365TP	\$13,403	RUS	\$1,075	7VM
125	5200	404TP	\$15,888	RU	404TP	\$16,525	RUE	404TP	\$17,060	RUS	\$1,347	7VM
150	5200	405TP	\$18,587	RU	405TP	\$19,862	RUE	405TP	\$23,782	RUS	\$1,427	7VM

The Open Motor Product is Not Available Below 254 Frame, Use TEFC

Momentary Upthrust Capacity is 30% of Standard High Thrust Design

• NRR = Non-Reverse Ratchet SRC= Self Release Coupling

**Cast Iron Frame

FRAME	STD. BD	ALT.BD	MAX BX	CD	FRAME	STD. BD	ALT.BD	MAX BX	CD
250	10	12-16.5	1.250	23.375 ++	447	16.5	20-24.5	2.250	49.780
280	10	12-16.5	1.250	24.750	449	24.5	20-30.5	2.500	49.780
320	16.5	12	1.501	28.219	5008	24.5	20-30.5	2.500	57.060
360	16.5	12	1.501	31.156	5012	24.5	20-30.5	2.750	72.300
400	16.5	20	1.688	36.938	5813	30.5	36	3.875	93.130
H444/445	16.5	20	2.250	44.780	6813	30.5	36-42	3.875	111.660

++ 20 HP, 4 Pole Energy and Premium Efficient CD is 24.750

See Page M-83 For Available And Alternate BD Dimensions

* 60Hz 3600, 1800, 1200 & 900 RPM motors comply with U.S. D.O.E.'s Efficiency regulation 10 CFR Section 431 Subpart B – electric motors (See Page M-80 - M-81 for Nominal Efficiency Table)



† All marks shown within this document are properties of their respective owners.

Three Phase Modifiable Motors
Vertical HOLLOSHAFT®
High Thrust - "P" Base
Weather Protected Type I (WPI)
4 Pole, 1800 RPM



APPLICATIONS:

For use on Turbine, Mix Flow and Propeller Pumps

FEATURES:

- * Class F Insulation, Class B Rise at Full Load (Sine Wave Power)
- * 1.15 Service Factor (Sine Wave Power)
- * Maximum 40 Deg. C. Ambient, 3,300 Feet Altitude
- * NEMA Design "B"
- * 3 Phase 60 Hz

200, 230/460, 575 Volts (&)

HP	Down Thrust (lbs) (#)	Standard Efficient			Energy Efficient			Premium Efficient			NRR List Adder	Disc. Sym
		Frame	SRC List	Type	Frame	SRC List	Type	Frame	SRC List	Type		
15	3300	254TP	\$3,277	AU	254TP	\$3,780	AUE	254TP	\$4,057	AUS	\$329	7VM
20	3300	256TP	\$3,732	AU	256TP	\$4,201	AUE	256TP	\$4,446	AUS	\$376	7VM
25	3300	284TP	\$4,164	AU	284TP	\$4,799	AUE	284TP	\$5,060	AUS	\$418	7VM
30	3300	286TP	\$4,685	AU	286TP	\$5,236	AUE	286TP	\$5,512	AUS	\$465	7VM
40	5700	324TP	\$6,425	RU	324TP	\$6,763	RUE	324TP	\$7,119	RUS	\$484	7VM
50	5700	326TP	\$7,158	RU	326TP	\$7,535	RUE	326TP	\$7,932	RUS	\$577	7VM
60	5700	364TP	\$8,539	RU	364TP	\$8,988	RUE	364TP	\$9,461	RUS	\$662	7VM
75	5700	365TP	\$9,712	RU	365TP	\$10,223	RUE	365TP	\$10,761	RUS	\$808	7VM
100	6700	404TP	\$11,596	RU	404TP	\$12,323	RUE	404TP	\$12,972	RUS	\$1,019	7VM
125	6700	405TP	\$14,005	RU	405TP	\$15,342	RUE	405TP	\$16,149	RUS	\$1,235	7VM
150	9800	H444TP	\$17,033	RU	H444TP	\$20,207	RUE	H444TP	\$21,270	RUS	\$1,300	7VM
200	9800	H445TP	\$23,141	RU	H445TP	\$25,900	RUE	H445TP	\$27,263	RUS	\$1,347	7VM
250	9800	H445TP	\$27,559	RU	H445TP	\$32,546	RUE	H445TP	\$34,682	RUS	\$1,347	7VM
300	9800	447TP@	\$31,693	RU	447TP@	\$37,428	RUE	447TP@	\$39,884	RUS	\$1,559	7VM
350	9800	447TP@	\$35,654	RU	447TP@	\$42,106	RUE	447TP@	\$44,870	RUS	\$1,559	7VM
400	9500	449TP@	\$51,082	RU	449TP@	\$60,655	RU	449TP@	\$63,847	RUS	\$1,570	8VM
450	9500	449TP@	\$57,467	RU	449TP@	\$68,253	RU	449TP@	\$71,845	RUS	\$1,596	8VM
500	9500	449TP@	\$66,877	RU	449TP@	\$73,063	RU	449TP@	\$76,908	RUE	\$1,761	8VM
600	9500	5008P	\$76,286	RU	---	---	---	5008P	\$94,552	RUE	\$1,908	8VM
700	10300	5012P	\$88,547	RU	---	---	---	5012P	\$109,857	RUE	\$2,214	8VM
800	10300	5012P	\$101,197	RU	---	---	---	5012P	\$125,552	RUE	\$2,531	8VM

The Open Motor Product Is Not Available Below 254 Frame, Use TEFC
 # Momentary Upthrust Capacity is 30% of Standard High Thrust Design
 & Standard Voltages Thru 404 Frame; 405 Frame & Larger, Single Voltage 460 or 575 standard
 @Contact your Nidec Motor Corporation Technical Representative for WPII frame size confirmation prior to quoting.
 +10,300 Lbs. Downthrust For 5012 Frame
 * NRR = Non-Reverse Ratchet SRC = Self Release Coupling
 See Page M-83 For Available And Alternate BD Dimensions

* 60Hz 3600, 1800, 1200 & 900 RPM motors comply with U.S. D.O.E.'s Efficiency regulation 10 CFR Section 431 Subpart B – electric motors (See Page M-80 - M-81 for Nominal Efficiency Table)



† All marks shown within this document are properties of their respective owners.

Three Phase Modifiable Motors
Vertical HOLLOSHAFT®
High Thrust - "P" Base
Weather Protected Type I (WPI)
4 Pole, 1800 RPM



APPLICATIONS:

For use on Turbine, Mix Flow and Propeller Pumps

FEATURES:

- * Class F Insulation, Class B Rise at Full Load (Sine Wave Power)
- * 1.15 Service Factor (Sine Wave Power)
- * Maximum 40 Deg. C. Ambient, 3,300 Feet Altitude
- * NEMA Design "B"
- * 3 Phase 60 Hz

2300 Volt

HP	Down Thrust (lbs) (#)	Standard Efficient				Premium Efficient				NRR List Adder	Disc. Sym
		Frame	BD (in)	SRC List	Type	Frame	BD (in)	SRC List	Type		
150	9800	447TP@	20	\$33,052	RU	447TP@	20	\$38,012	RUS	\$1,761	8VM
200	9800	447TP@	20	\$36,533	RU	447TP@	20	\$42,009	RUS	\$1,761	8VM
250	9800	447TP@	20	\$40,822	RU	449TP@	24.5	\$46,946	RUS	\$1,843	8VM
300	9500	449TP@	24.5	\$45,923	RU	449TP@	24.5	\$52,812	RUS	\$1,873	8VM
350	9500	5008P	24.5	\$51,791	RU	5008P	24.5	\$59,561	RUE	\$1,873	8VM
400	9500	5008P	24.5	\$54,742	RU	5008P	24.5	\$62,953	RUE	\$1,960	8VM
450	9500	5008P	24.5	\$62,244	RU	5008P	24.5	\$71,582	RUE	\$1,960	8VM
500	9500	5008P	24.5	\$69,350	RU	5012P+	24.5	\$79,751	RUE	\$1,995	8VM
600	10300	5012P	24.5	\$83,770	RU	5012P	24.5	\$96,336	RUE	\$2,183	8VM
700	10300	5012P	24.5	\$95,197	RU	5012P	24.5	\$109,474	RUE	\$2,425	8VM
800	10300	5012P	24.5	\$106,681	RU	5012P	24.5	\$122,685	RUE	\$2,425	8VM
900	10300	5012P	24.5	\$119,998	RU	5012P	24.5	\$137,995	RUE	\$2,484	8VM
1000	10300	5012P	24.5	\$133,195	RU	5012P	24.5	\$153,176	RUE	\$2,484	8VM
1250	11900	5813P	30.5	\$166,486	RU	5813P	30.5	\$191,458	RUE	\$3,312	8VM
1500	11900	5813P	30.5	\$190,472	RU	5813P	30.5	\$219,045	RUE	\$3,930	8VM
1750	11900	5813P	30.5	\$223,075	RU	5813P	30.5	\$256,538	RUE	\$5,441	8VM
2000	10300	6810P	30.5	\$239,063	RU	6810P	30.5	\$274,925	RUE	\$5,977	9VM
2250	10300	6810P	30.5	\$252,324	RU	6810P	30.5	\$290,174	RUE	\$6,165	9VM
2500	10300	6811P	30.5	\$254,080	RU	6811P	30.5	\$292,190	RUE	\$6,352	9VM
3000	10300	6813P	30.5	\$367,491	RU	6813P	30.5	\$422,615	RUE	\$10,289	9VM
3500	10300	6813P	30.5	\$422,394	RU	6813P	30.5	\$466,857	RUE	\$11,369	9VM
4000*	10300	6813P	30.5	\$424,340	RU	6813P	30.5	\$487,991	RUE	\$11,880	9VM
4500*	8600	9608PH	42	\$450,082	RU	9608PH	42	\$517,594	RUE	\$12,603	9VM
5000*	8600	9608PH	42	\$474,444	RU	9608PH	42	\$545,610	RUE	\$13,284	9VM

Momentary Upthrust Capacity is 30% of Standard High Thrust Design
 @Contact your Nidec Motor Corporation Technical Representative for WPII frame size confirmation prior to quoting, 9500 Lbs. Downthrust + 10,300 Lbs Down Thrust for 5012 Frame
 * Maximum Full Load Test Capacity is 3500 HP
 • NRR = Non-Reverse Ratchet SRC= Self Release Coupling

See Page M-83 For Available And Alternate BD Dimensions



† All marks shown within this document are properties of their respective owners.

Three Phase Modifiable Motors
Vertical HOLLOSHAFT®
High Thrust - “P” Base
Weather Protected Type I (WPI)
4 Pole, 1800 RPM



APPLICATIONS:

For use on Turbine, Mix Flow and Propeller Pumps

FEATURES:

- * Class F Insulation, Class B Rise at Full Load (Sine Wave Power)
- * 1.15 Service Factor (Sine Wave Power)
- * Maximum 40 Deg. C. Ambient, 3,300 Feet Altitude
- * NEMA Design “B”
- * 3 Phase 60 Hz

4000 Volt

HP	Down Thrust (lbs) (#)	Standard Efficient				Premium Efficient				NRR List Adder	Disc. Sym
		Frame	BD (in)	SRC List	Type	Frame	BD(in)	SRC List	Type		
150	9500	449TP@	24.5	\$39,411	RU	449TP@	24.5	\$45,324	RUS	\$1,761	8VM
200	9500	449TP@	24.5	\$42,378	RU	449TP@	24.5	\$48,732	RUS	\$1,761	8VM
250	9500	449TP@	24.5	\$46,230	RU	449TP@	24.5	\$53,164	RUS	\$1,843	8VM
300	9500	449TP@	24.5	\$52,005	RU	449TP@	24.5	\$59,803	RUS	\$1,873	8VM
350	9500	5008P	24.5	\$58,692	RU	5008P	24.5	\$67,495	RUE	\$1,873	8VM
400	9500	5008P	24.5	\$62,418	RU	5008P	24.5	\$71,782	RUE	\$1,960	8VM
450	9500	5008P	24.5	\$70,765	RU	5008P	24.5	\$81,383	RUE	\$1,960	8VM
500	9500	5008P	24.5	\$79,451	RU	5012P+	24.5	\$91,371	RUE	\$1,995	8VM
600	10300	5012P	24.5	\$93,951	RU	5012P	24.5	\$108,042	RUE	\$2,183	8VM
700	10300	5012P	24.5	\$107,192	RU	5012P	24.5	\$123,272	RUE	\$2,425	8VM
800	10300	5012P	24.5	\$120,171	RU	5012P	24.5	\$138,195	RUE	\$2,425	8VM
900	10300	5012P	24.5	\$134,822	RU	5012P	24.5	\$155,023	RUE	\$2,484	8VM
1000	10300	5012P	24.5	\$149,373	RU	5012P	24.5	\$171,779	RUE	\$2,484	8VM
1250	11900	5813P	30.5	\$183,711	RU	5813P	30.5	\$211,268	RUE	\$3,312	8VM
1500	11900	5813P	30.5	\$209,167	RU	5813P	30.5	\$240,542	RUE	\$3,930	8VM
1750	11900	5813P	30.5	\$249,190	RU	5813P	30.5	\$286,481	RUE	\$5,441	8VM
2000	10300	6810P	30.5	\$267,754	RU	6810P	30.5	\$307,913	RUE	\$5,977	9VM
2250	10300	6810P	30.5	\$276,031	RU	6810P	30.5	\$317,437	RUE	\$5,977	9VM
2500	10300	6811P	30.5	\$284,568	RU	6811P	30.5	\$327,254	RUE	\$6,352	9VM
3000	10300	6813P	30.5	\$411,592	RU	6813P	30.5	\$473,331	RUE	\$10,289	9VM
3500	10300	6813P	30.5	\$454,678	RU	6813P	30.5	\$522,878	RUE	\$11,369	9VM
4000*	10300	6813P	30.5	\$475,261	RU	6813P	30.5	\$546,549	RUE	\$11,880	9VM
4500*	8600	9608PH	42	\$504,094	RU	9608PH	42	\$579,707	RUE	\$12,603	9VM
5000*	8600	9608PH	42	\$531,376	RU	9608PH	42	\$611,082	RUE	\$13,284	9VM

Momentary Upthrust Capacity is 30% of Standard High Thrust Design
+ 10,300 Lbs. Downthrust for 5012 Frame
*Maximum Full Load Test Capacity is 3500 HP
• NRR = Non-Reverse Ratchet SRC= Self Release Coupling
@Contact your Nidec Motor Corporation Technical Representative for WPII frame size confirmation prior to quoting.

See Page M-83 For Available And Alternate BD Dimensions



Three Phase Modifiable Motors
Vertical HOLLOSHAFT®
High Thrust - "P" Base
Weather Protected Type I (WPI)
6 Pole, 1200 RPM



APPLICATIONS:

For use on Turbine, Mix Flow and Propeller Pumps

FEATURES:

- * Class F Insulation, Class B Rise at Full Load (Sine Wave Power)
- * 1.15 Service Factor (Sine Wave Power)
- * Maximum 40 Deg. C. Ambient, 3,300 Feet Altitude
- * NEMA Design "B"
- * 3 Phase 60 Hz

200, 230/460, 575 Volts (&)

HP	Down Thrust (lbs) (#)	Standard Efficient			Energy Efficient			Premium Efficient			NRR List Adder	Disc. Sym
		Frame	SRC List	Type	Frame	SRC List	Type	Frame	SRC List	Type		
7.5	3800	254TP	\$3,329	AU	254TP	\$4,063	AUE	254TP	\$4,307	AUS	\$376	7VM
10	3800	256TP	\$3,761	AU	256TP	\$4,629	AUE	256TP	\$4,907	AUS	\$385	7VM
15	3800	284TP	\$4,385	AU	284TP	\$5,507	AUE	284TP	\$5,837	AUS	\$411	7VM
20	3800	286TP	\$5,329	AU	286TP	\$6,451	AUE	286TP	\$6,838	AUS	\$469	7VM
25	6700	324TP	\$6,150	RU	324TP	\$7,617	RUE	324TP	\$7,998	RUS	\$540	7VM
30	6700	326TP	\$7,019	RU	326TP	\$8,486	RUE	326TP	\$8,911	RUS	\$620	7VM
40	6700	364TP	\$8,577	RU	364TP	\$11,181	RUE	364TP	\$11,739	RUS	\$756	7VM
50	6700	365TP	\$10,113	RU	365TP	\$12,716	RUE	365TP	\$13,352	RUS	\$869	7VM
60	7800	404TP	\$11,549	RU	404TP	\$15,167	RUE	404TP	\$15,925	RUS	\$1,019	7VM
75	7800	405TP	\$13,582	RU	405TP	\$17,200	RUE	405TP	\$18,059	RUS	\$1,197	7VM
100	11250	H444TP	\$16,775	RU	H444TP	\$22,305	RUE	H444TP	\$23,420	RUS	\$1,549	7VM
125	11250	H445TP	\$20,277	RU	H445TP	\$25,808	RUE	H445TP	\$27,099	RUS	\$1,549	7VM
150	11250	H445TP	\$24,493	RU	H445TP	\$30,023	RUE	H445TP	\$31,526	RUS	\$1,878	7VM
200	11250	447TP@	\$30,616	RU	447TP@	\$37,529	RUE	447TP@	\$39,408	RUS	\$1,756	7VM
250	11250	447TP@	\$37,505	RU	447TP@	\$45,973	RUE	447TP@	\$48,274	RUS	\$1,756	7VM
300	11000	449TP@	\$50,563	RU	449TP@	\$60,050	RU	449TP@	\$63,211	RUS	\$1,770	8VM
350	11000	5008P	\$58,399	RU	5008P	\$69,345	RU	5008P	\$72,995	RUE	\$1,784	8VM
400	11000	5008P	\$66,890	RU	5012P+	\$79,434	RU	5012P+	\$83,615	RUE	\$1,808	8VM
450	11900	5012P	\$74,002	RU	5012P	\$87,877	RU	5012P	\$92,502	RUE	\$2,066	8VM
500	11900	5012P	\$81,502	RU	5012P	\$96,773	RU	5012P	\$101,866	RUE	\$2,272	8VM
600	11900	5012P	\$97,803	RU	---	---	---	5012P	\$121,568	RUE	\$2,448	8VM
700	11900	5012P	\$114,103	RU	---	---	---	5012P	\$141,826	RUE	\$2,854	8VM
800	13700	5813P	\$130,387	RU	---	---	---	5813P	\$163,007	RUE	\$3,258	8VM

The Open Motor Product Is Not Available Below 254 Frame, Use TEFC
 # Momentary Upthrust Capacity is 30% of Standard High Thrust Design
 & Standard Voltages Thru 405 Frame; 444 Frame & Larger, Single Voltage 460 or 575 is standard
 @Contact your Nidec Motor Corporation Technical Representative for WPII frame size confirmation prior to quoting.
 + 11,900 LBS Down Thrust
 • NRR = Non-Reverse Ratchet SRC= Self Release Coupling
 * 60Hz 3600, 1800, 1200 & 900 RPM motors comply with U.S. D.O.E.'s Efficiency regulation 10 CFR Section 431 Subpart B – electric motors (See Page M-80 - M-81 for Nominal Efficiency Table)

See Page M-83 For Available And Alternate BD Dimensions



† All marks shown within this document are properties of their respective owners.

Three Phase Modifiable Motors
Vertical HOLLOSHAFT®
High Thrust - "P" Base
Weather Protected Type I (WPI)
6 Pole, 1200 RPM



APPLICATIONS:

For use on Turbine, Mix Flow and Propeller Pumps

FEATURES:

- * Class F Insulation, Class B Rise at Full Load (Sine Wave Power)
- * 1.15 Service Factor (Sine Wave Power)
- * Maximum 40 Deg. C. Ambient, 3,300 Feet Altitude
- * NEMA Design "B"
- * 3 Phase 60 Hz

2300 Volt

HP	Down Thrust (lbs) (#)	Standard Efficient				Premium Efficient				NRR List Adder	Disc. Sym
		Frame	BD (in)	SRC List	Type	Frame	BD (in)	SRC List	Type		
150	11000	449TP@	24.5	\$39,185	RU	449TP@	24.5	\$45,061	RUS	\$1,761	8VM
200	11000	449TP@	24.5	\$45,373	RU	449TP@	24.5	\$52,178	RUS	\$1,761	8VM
250	11000	449TP@	24.5	\$53,927	RU	449TP@	24.5	\$62,016	RUS	\$1,831	8VM
300	11000	5008P	24.5	\$58,805	RU	5008P	24.5	\$67,627	RUE	\$1,890	8VM
350	11000	5008P	24.5	\$69,538	RU	5008P	24.5	\$79,967	RUE	\$2,120	8VM
400	11000	5008P	24.5	\$76,702	RU	5012P+	24.5	\$88,207	RUE	\$2,214	8VM
450	11000	5008P	24.5	\$83,986	RU	5012P+	24.5	\$96,582	RUE	\$2,343	8VM
500	11900	5012P	24.5	\$90,599	RU	5012P	24.5	\$104,188	RUE	\$2,531	8VM
600	11900	5012P	24.5	\$106,779	RU	5012P	24.5	\$122,796	RUE	\$2,608	8VM
700	11900	5012P	24.5	\$118,742	RU	5012P	24.5	\$136,552	RUE	\$4,991	8VM
800	13700	5813P	30.5	\$129,627	RU	5813P	30.5	\$149,073	RUE	\$5,502	8VM
900	13700	5813P	30.5	\$143,845	RU	5813P	30.5	\$165,420	RUE	\$5,777	8VM
1000	13700	5813P	30.5	\$156,491	RU	5813P	30.5	\$179,965	RUE	\$5,981	8VM
1250	13700	5813P	30.5	\$179,779	RU	5813P	30.5	\$206,746	RUE	\$6,099	8VM
1500	11900	6810P	30.5	\$204,862	RU	6810P	30.5	\$235,594	RUE	\$6,176	8VM
1750	11900	6810P	30.5	\$230,930	RU	6810P	30.5	\$265,570	RUE	\$6,305	9VM
2000	11900	6811P	30.5	\$263,908	RU	6811P	30.5	\$303,495	RUE	\$6,599	9VM
2250	11900	6813P	30.5	\$296,899	RU	6813P	30.5	\$341,432	RUE	\$7,420	9VM
2500	11900	6813P	30.5	\$329,885	RU	6813P	30.5	\$379,369	RUE	\$8,249	9VM
3000	10400	9606PH	42	\$370,129	RU	9606PH	42	\$425,648	RUE	\$9,995	9VM
3500	10400	9607PH	42	\$419,352	RU	9607PH	42	\$482,254	RUE	\$11,324	9VM
4000*	10400	9608PH	42	\$479,732	RU	9608PH	42	\$551,692	RUE	\$12,953	9VM

Momentary Upthrust Capacity is 30% of Standard High Thrust Design
+ 11,900 Lbs. Downthrust for 5012 Frame
* Maximum Full Load Test Capacity Is 3500 HP
• NRR = Non-Reverse Ratchet SRC= Self Release Coupling
@Contact your Nidec Motor Corporation Technical Representative for WPII frame size confirmation prior to quoting.

See Page M-83 For Available And Alternate BD Dimensions



Three Phase Modifiable Motors
Vertical HOLLOSHAFT®
High Thrust - "P" Base
Weather Protected Type I (WPI)
6 Pole, 1200 RPM



APPLICATIONS:

For use on Turbine, Mix Flow and Propeller Pumps

FEATURES:

- * Class F Insulation, Class B Rise at Full Load (Sine Wave Power)
- * 1.15 Service Factor (Sine Wave Power)
- * Maximum 40 Deg. C. Ambient, 3,300 Feet Altitude
- * NEMA Design "B"
- * 3 Phase 60 Hz

4000 Volt

HP	Down Thrust (lbs) (#)	Standard Efficient				Premium Efficient				NRR List Adder	Disc. Sym
		Frame	BD (in)	SRC List	Type	Frame	BD (in)	SRC List	Type		
150	11000	449TP@	24.5	\$49,526	RU	449TP@	24.5	\$56,955	RUS	\$1,761	8VM
200	11000	5008P	24.5	\$57,347	RU	5008P	24.5	\$65,951	RUE	\$1,831	8VM
250	11000	5008P	24.5	\$61,150	RU	5008P	24.5	\$70,324	RUE	\$1,831	8VM
300	11000	5008P	24.5	\$67,131	RU	5008P	24.5	\$77,202	RUE	\$1,890	8VM
350	11000	5008P	24.5	\$78,887	RU	5008P	24.5	\$90,723	RUE	\$2,120	8VM
400	11000	5008P	24.5	\$87,045	RU	5012P+	24.5	\$100,103	RUE	\$2,214	8VM
450	11000	5008P	24.5	\$94,401	RU	5012P+	24.5	\$108,563	RUE	\$2,343	8VM
500	11900	5012P	24.5	\$101,587	RU	5012P	24.5	\$116,826	RUE	\$2,531	8VM
600	11900	5012P	24.5	\$118,829	RU	5012P	24.5	\$136,655	RUE	\$2,608	8VM
700	11900	5012P	24.5	\$131,216	RU	5012P	24.5	\$150,899	RUE	\$4,991	8VM
800	13700	5813P	30.5	\$144,216	RU	5813P	30.5	\$165,847	RUE	\$5,502	8VM
900	13700	5813P	30.5	\$158,404	RU	5813P	30.5	\$182,167	RUE	\$5,777	8VM
1000	13700	5813P	30.5	\$171,406	RU	5813P	30.5	\$197,115	RUE	\$5,981	8VM
1250	13700	5813P	30.5	\$193,357	RU	5813P	30.5	\$222,359	RUE	\$6,099	8VM
1500	11900	6810P	30.5	\$220,331	RU	6810P	30.5	\$253,380	RUE	\$6,176	8VM
1750	11900	6810P	30.5	\$249,404	RU	6810P	30.5	\$286,817	RUE	\$6,305	9VM
2000	11900	6811P	30.5	\$285,021	RU	6811P	30.5	\$327,772	RUE	\$6,599	9VM
2250	11900	6813P	30.5	\$320,505	RU	6813P	30.5	\$368,580	RUE	\$7,420	9VM
2500	11900	6813P	30.5	\$356,277	RU	6813P	30.5	\$409,718	RUE	\$8,249	9VM
3000	10400	9606PH	42	\$399,739	RU	9606PH	42	\$459,702	RUE	\$9,995	9VM
3500	10400	9607PH	42	\$452,899	RU	9607PH	42	\$520,833	RUE	\$11,324	9VM
4000*	10400	9608PH	42	\$518,110	RU	9608PH	42	\$595,829	RUE	\$12,953	9VM

Momentary Upthrust Capacity is 30% of Standard High Thrust Design
+ 11,900 Lbs. Downthrust for 5012 Frame
* Maximum Full Load Test Capacity is 3500 HP
• NRR = Non-Reverse Ratchet SRC= Self Release Coupling
@Contact your Nidec Motor Corporation Technical Representative for WPII frame size confirmation prior to quoting.

See Page M-83 For Available And Alternate BD Dimensions



Three Phase Modifiable Motors
Vertical HOLLOSHAFT®
High Thrust - "P" Base
Weather Protected Type I (WPI)
8 Pole, 900 RPM



APPLICATIONS:

For use on Turbine, Mix Flow and Propeller Pumps

FEATURES:

- * Class F Insulation, Class B Rise at Full Load (Sine Wave Power)
- * 1.15 Service Factor (Sine Wave Power)
- * Maximum 40 Deg. C. Ambient, 3,300 Feet Altitude
- * NEMA Design "B"
- * 3 Phase 60 Hz

200, 230/460, 575 Volts (&)

HP	Down Thrust (lbs) (#)	Standard Efficient			Energy Efficient			Premium Efficient			NRR List Adder	Disc. Sym
		Frame	SRC List	Type	Frame	SRC List	Type	Frame	SRC List	Type		
5	4200	254TP	\$3,352	AU	254TP	\$4,221	AUE	254TP	\$4,474	AUS	\$333	7VM
7.5	4200	256TP	\$3,859	AU	256TP	\$4,728	AUE	256TP	\$5,012	AUS	\$385	7VM
10	4200	284TP	\$4,268	AU	284TP	\$5,390	AUE	284TP	\$5,713	AUS	\$427	7VM
15	4200	286TP	\$5,432	AU	286TP	\$6,554	AUE	286TP	\$6,947	AUS	\$540	7VM
20	7400	324TP	\$6,366	RU	324TP	\$7,833	RUE	324TP	\$8,225	RUS	\$563	7VM
25	7400	326TP	\$7,333	RU	326TP	\$8,800	RUE	326TP	\$9,239	RUS	\$643	7VM
30	7400	364TP	\$8,225	RU	364TP	\$10,829	RUE	364TP	\$11,371	RUS	\$728	7VM
40	7400	365TP	\$9,915	RU	365TP	\$12,519	RUE	365TP	\$13,146	RUS	\$873	7VM
50	8600	404TP	\$11,300	RU	404TP	\$14,918	RUE	404TP	\$15,664	RUS	\$995	7VM
60	8600	405TP	\$13,033	RU	405TP	\$16,650	RUE	405TP	\$17,484	RUS	\$1,150	7VM
75	12500	H444TP	\$15,197	RU	H444TP	\$19,023	RUE	H444TP	\$19,974	RUS	\$1,164	7VM
100	12500	H445TP	\$20,329	RU	H445TP	\$24,439	RUE	H445TP	\$25,662	RUS	\$1,554	7VM
125	12500	447TP@	\$28,461	RU	447TP@	\$34,215	RUE	447TP@	\$35,927	RUS	\$1,937	7VM
150	12500	447TP@	\$32,018	RU	447TP@	\$38,491	RUE	447TP@	\$40,418	RUS	\$1,937	7VM
200	12000	449TP@	\$43,387	RU	449TP@	\$47,166	RU	449TP@	\$49,648	RUS	\$1,981	8VM
250	12000	5008P	\$52,472	RU	5008P	\$57,063	RU	5008P	\$60,066	RUE	\$2,011	8VM
300	13200	5012P	\$61,779	RU	5012P	\$67,058	RU	5012P	\$70,587	RUE	\$2,054	8VM
350	13200	5012P	\$71,655	RU	5012P	\$77,987	RU	5012P	\$82,092	RUE	\$2,230	8VM
400	13200	5012P	\$81,174	RU	5012P	\$88,361	RU	5012P	\$93,012	RUE	\$2,265	8VM
450	13200	5012P	\$90,629	RU	5012P	\$98,653	RU	5012P	\$103,845	RUE	\$2,531	8VM
500	13200	5012P	\$99,678	RU	5012P	\$108,578	RU	5012P	\$114,293	RUE	\$3,516	8VM
600	15000	5813P	\$131,596	RU	---	---	---	5813P	\$149,117	RUE	\$4,608	8VM
700	15000	5813P	\$146,962	RU	---	---	---	5813P	\$167,425	RUE	\$5,143	8VM
800	15000	5813P	\$167,958	RU	---	---	---	5813P	\$191,340	RUE	\$5,878	8VM

The Open Motor Product Is Not Available Below 254 Frame, Use TEFC
 # Momentary Upthrust Capacity is 30% of Standard High Thrust Design
 & Standard Voltages Thru 404 Frame; 405 Frame & Larger, Single Voltage 460 or 575 standard
 @Contact your Nidec Motor Corporation Technical Representative for WPII frame size confirmation prior to quoting.
 + 13,200 Lbs. Downthrust
 • NRR = Non-Reverse Ratchet SRC= Self Release Coupling
 * 60Hz 3600, 1800, 1200 & 900 RPM motors comply with U.S. D.O.E.'s Efficiency regulation 10 CFR Section 431 Subpart B – electric motors (See Page M-80 - M-81 for Nominal Efficiency Table)

See Page M-83 For Available And Alternate BD Dimensions

† All marks shown within this document are properties of their respective owners.



Three Phase Modifiable Motors
Vertical HOLLOSHAFT®
High Thrust - "P" Base
Weather Protected Type I (WPI)
8 Pole, 900 RPM



APPLICATIONS:

For use on Turbine, Mix Flow and Propeller Pumps

FEATURES:

- * Class F Insulation, Class B Rise at Full Load (Sine Wave Power)
- * 1.15 Service Factor (Sine Wave Power)
- * Maximum 40 Deg. C. Ambient, 3,300 Feet Altitude
- * NEMA Design "B"
- * 3 Phase 60 Hz

2300 Volt

HP	Down Thrust (lbs) (#)	Standard Efficient				Premium Efficient				NRR List Adder	Disc. Sym
		Frame	BD (in)	SRC List	Type	Frame	BD (in)	SRC List	Type		
150	12000	449TP@	24.5	\$44,995	RU	449TP@	24.5	\$51,744	RUS	\$1,995	8VM
200	12000	5008P	24.5	\$55,737	RU	5008P	24.5	\$64,096	RUE	\$2,009	8VM
250	12000	5008P	24.5	\$66,585	RU	5012P+	24.5	\$76,573	RUE	\$2,049	8VM
300	13200	5012P	24.5	\$75,653	RU	5012P	24.5	\$86,998	RUE	\$2,167	8VM
350	13200	5012P	24.5	\$84,772	RU	5012P	24.5	\$97,488	RUE	\$2,366	8VM
400	13200	5012P	24.5	\$93,697	RU	5012P	24.5	\$107,754	RUE	\$2,617	8VM
450	13200	5012P	24.5	\$101,838	RU	5012P	24.5	\$117,113	RUE	\$2,840	8VM
500	13200	5012P	24.5	\$118,296	RU	5012P	24.5	\$136,040	RUE	\$3,516	8VM
600	15000	5813P	30.5	\$130,883	RU	5813P	30.5	\$150,516	RUE	\$3,521	8VM
700	15000	5813P	30.5	\$141,617	RU	5813P	30.5	\$162,859	RUE	\$3,695	8VM
800	15000	5813P	30.5	\$154,930	RU	5813P	30.5	\$178,169	RUE	\$3,979	8VM
900	15000	5813P	30.5	\$170,162	RU	5813P	30.5	\$195,688	RUE	\$4,096	8VM
1000	15000	5813P	30.5	\$182,777	RU	5813P	30.5	\$210,195	RUE	\$4,343	8VM
1250	13100	6810P	30.5	\$205,552	RU	6810P	30.5	\$236,385	RUE	\$5,138	8VM
1500	13100	6811P	30.5	\$238,261	RU	6811P	30.5	\$274,000	RUE	\$6,254	9VM
1750	13100	6813P	30.5	\$270,153	RU	6813P	30.5	\$310,676	RUE	\$7,296	9VM
2000	13100	6813P	30.5	\$308,744	RU	6813P	30.5	\$355,056	RUE	\$8,336	9VM
2250	13100	8011PH	42	\$347,336	RU	8011PH~	42	\$399,437	RUE	\$9,380	9VM
2500	12100	9605PH	42	\$385,930	RU	9605PH	42	\$443,822	RUE	\$10,420	9VM
3000	12100	9607PH	42	\$433,012	RU	9607PH	42	\$497,965	RUE	\$11,690	9VM
3500	12100	9608PH	42	\$490,596	RU	9608PH	42	\$564,185	RUE	\$13,246	9VM

Momentary Upthrust Capacity is 30% of Standard High Thrust Design
+ 13,200 Lbs. Downthrust for 5012 Frame
~ Not For WPII Enclosure
• NRR = Non-Reverse Ratchet SRC= Self Release Coupling
@Contact your Nidec Motor Corporation Technical Representative for WPII frame size confirmation prior to quoting.

See Page M-83 For Available And Alternate BD Dimensions



† All marks shown within this document are properties of their respective owners.

Three Phase Modifiable Motors
Vertical HOLLOSHAFT®
High Thrust - "P" Base
Weather Protected Type I (WPI)
8 Pole, 900 RPM



APPLICATIONS:

For use on Turbine, Mix Flow and Propeller Pumps

FEATURES:

- * Class F Insulation, Class B Rise at Full Load (Sine Wave Power)
- * 1.15 Service Factor (Sine Wave Power)
- * Maximum 40 Deg. C. Ambient, 3,300 Feet Altitude
- * NEMA Design "B"
- * 3 Phase 60 Hz

4000 Volt

HP	Down Thrust (lbs) (#)	Standard Efficient				Premium Efficient				NRR List Adder	Disc. Sym
		Frame	BD (in)	SRC List	Type	Frame	BD (in)	SRC List	Type		
150	12000	449TP@	24.5	\$63,178	RU	449TP@	24.5	\$72,655	RUS	\$1,995	8VM
200	12000	5008P	24.5	\$65,282	RU	5008P	24.5	\$75,073	RUE	\$2,009	8VM
250	12000	5008P	24.5	\$75,484	RU	5012P+	24.5	\$86,808	RUE	\$2,049	8VM
300	13200	5012P	24.5	\$85,793	RU	5012P	24.5	\$98,662	RUE	\$2,178	8VM
350	13200	5012P	24.5	\$94,249	RU	5012P	24.5	\$108,387	RUE	\$2,366	8VM
400	13200	5012P	24.5	\$104,174	RU	5012P	24.5	\$119,798	RUE	\$2,617	8VM
450	13200	5012P	24.5	\$113,223	RU	5012P	24.5	\$130,207	RUE	\$2,840	8VM
500	13200	5012P	24.5	\$131,678	RU	5012P	24.5	\$151,430	RUE	\$3,516	8VM
600	15000	5813P	30.5	\$145,690	RU	5813P	30.5	\$167,545	RUE	\$3,521	8VM
700	15000	5813P	30.5	\$157,195	RU	5813P	30.5	\$180,775	RUE	\$3,695	8VM
800	15000	5813P	30.5	\$171,972	RU	5813P	30.5	\$197,770	RUE	\$3,979	8VM
900	15000	5813P	30.5	\$188,880	RU	5813P	30.5	\$217,214	RUE	\$4,096	8VM
1000	15000	5813P	30.5	\$202,876	RU	5813P	30.5	\$233,308	RUE	\$4,343	8VM
1250	13100	6810P	30.5	\$224,070	RU	6810P	30.5	\$257,678	RUE	\$5,138	9VM
1500	13100	6811P	30.5	\$255,117	RU	6811P	30.5	\$293,385	RUE	\$6,254	9VM
1750	13100	6813P	30.5	\$291,763	RU	6813P	30.5	\$335,528	RUE	\$7,296	9VM
2000	13100	6813P	30.5	\$333,446	RU	6813P	30.5	\$383,462	RUE	\$8,336	9VM
2250	12100	9606PH	42	\$375,124	RU	9606PH	42	\$431,392	RUE	\$9,380	9VM
2500	12100	9606PH	42	\$416,805	RU	9607PH	42	\$479,326	RUE	\$10,420	9VM
3000	12100	9607PH	42	\$467,650	RU	9607PH	42	\$537,796	RUE	\$11,690	9VM
3500	12100	9608PH	42	\$529,843	RU	9608PH	42	\$609,317	RUE	\$13,246	9VM

Momentary Upthrust Capacity is 30% of Standard High Thrust Design
+ 13,200 Lbs. Downthrust for 5012 Frame
~ Not For WPII Enclosure
• NRR = Non-Reverse Ratchet SRC= Self Release Coupling
@Contact your Nidec Motor Corporation Technical Representative for WPII frame size confirmation prior to quoting.

See Page M-83 For Available And Alternate BD Dimensions



Three Phase Modifiable Motors
Vertical HOLLOSHAFT®
High Thrust - "P" Base
Weather Protected Type I (WPI)
10 Pole, 720 RPM



APPLICATIONS:

For use on Turbine, Mix Flow and Propeller Pumps

FEATURES:

- * Class F Insulation, Class B Rise at Full Load (Sine Wave Power)
- * 1.15 Service Factor (Sine Wave Power)
- * Maximum 40 Deg. C. Ambient, 3,300 Feet Altitude
- * NEMA Design "B"
- * 3 Phase 60 Hz

200, 230/460 575 Volts (&)

HP	Down Thrust (lbs) (#)	Standard Efficient			Premium Efficient			NRR List Adder	Disc. Sym
		Frame	SRC List	Type	Frame	SRC List	Type		
15	8000	326TP	\$7,606	RU	326TP	\$9,106	RUS	\$685	7VM
20	8000	364TP	\$8,913	RU	364TP	\$10,669	RUS	\$803	7VM
25	8000	365TP	\$10,268	RU	365TP	\$12,291	RUS	\$925	7VM
30	9300	404TP	\$11,516	RU	404TP	\$13,786	RUS	\$1,038	7VM
40	9300	405TP	\$13,878	RU	405TP	\$16,606	RUS	\$1,225	7VM
50	13500	H444TP	\$16,033	RU	H444TP	\$19,190	RUS	\$1,230	7VM
60	13500	H445TP	\$17,671	RU	H445TP	\$21,251	RUS	\$1,526	7VM
75	13500	H445TP	\$21,878	RU	H445TP	\$26,188	RUS	\$1,671	7VM
100	13500	447TP@	\$30,629	RU	447TP@	\$36,663	RUS	\$1,873	7VM
125	13500	447TP@	\$34,458	RU	447TP@	\$41,246	RUS	\$1,897	7VM
150	13000	449TP@	\$49,984	RU	449TP@	\$57,157	RUE	\$2,000	9VM
200	13000	5008P	\$64,326	RU	5008P	\$73,613	RUE	\$2,354	9VM
250	14100	5012P	\$69,685	RU	5012P	\$79,796	RUE	\$2,425	9VM
300	14100	5012P	\$75,047	RU	5012P	\$85,981	RUE	\$2,495	9VM
350	14100	5012P	\$86,063	RU	5012P	\$98,613	RUE	\$2,671	9VM
400	16300	5813P	\$125,279	RU	5813P	\$143,601	RUE	\$3,756	9VM
450	16300	5813P	\$138,077	RU	5813P	\$158,272	RUE	\$4,143	9VM
500	16300	5813P	\$141,286	RU	5813P	\$161,946	RUE	\$4,239	9VM
600	16300	5813P	\$169,014	RU	5813P	\$193,732	RUE	\$5,070	9VM
700	16300	5813P	\$197,183	RU	5813P	\$226,021	RUE	\$6,181	9VM
800	16300	5813P	\$225,352	RU	5813P	\$258,310	RUE	\$6,761	9VM

Momentary Upthrust Capacity is 30% of Standard High Thrust Design
 & Standard Voltages Thru 404 Frame; 405 Frame & Larger, Single Voltage 460 or 575 standard
 @Contact your Nidec Motor Corporation Technical Representative for WPII frame size confirmation prior to quoting.
 • NRR = Non-Reverse Ratchet SRC= Self Release Coupling

See Page M-83 For Available And Alternate BD Dimensions



Three Phase Modifiable Motors
Vertical HOLLOSHAFT®
High Thrust - "P" Base
Weather Protected Type I (WPI)
10 Pole, 720 RPM



APPLICATIONS:

For use on Turbine, Mix Flow and Propeller Pumps

FEATURES:

- * Class F Insulation, Class B Rise at Full Load (Sine Wave Power)
- * 1.15 Service Factor (Sine Wave Power)
- * Maximum 40 Deg. C. Ambient, 3,300 Feet Altitude
- * NEMA Design "B"
- * 3 Phase 60 Hz

2300 Volt

HP	Down Thrust (lbs) (#)	Standard Efficient				Premium Efficient				NRR List Adder	Disc. Sym
		Frame	BD (in)	SRC List	Type	Frame	BD (in)	SRC List	Type		
150	13000	5008P	24.5	\$58,822	RU	5008P	24.5	\$67,643	RUE	\$2,439	9VM
200	13000	5008P	24.5	\$72,413	RU	5008P	24.5	\$83,275	RUE	\$2,439	9VM
250	14100	5012P	24.5	\$75,653	RU	5012P	24.5	\$86,998	RUE	\$2,671	9VM
300	14100	5012P	24.5	\$87,143	RU	5012P	24.5	\$100,214	RUE	\$2,721	9VM
350	14100	5012P	24.5	\$98,157	RU	5012P	24.5	\$112,883	RUE	\$3,070	9VM
400	16300	5813P	30.5	\$119,411	RU	5813P	30.5	\$137,322	RUE	\$3,331	9VM
450	16300	5813P	30.5	\$132,209	RU	5813P	30.5	\$152,042	RUE	\$3,700	9VM
500	16300	5813P	30.5	\$135,418	RU	5813P	30.5	\$155,728	RUE	\$3,793	9VM
600	16300	5813P	30.5	\$163,146	RU	5813P	30.5	\$187,617	RUE	\$4,568	9VM
700	16300	5813P	30.5	\$166,864	RU	5813P	30.5	\$191,892	RUE	\$4,577	9VM
800	16300	5813P	30.5	\$183,768	RU	5813P	30.5	\$211,333	RUE	\$4,948	9VM
900	14100	6810P	30.5	\$200,655	RU	6810P	30.5	\$230,751	RUE	\$5,326	9VM
1000	14100	6811P	30.5	\$217,430	RU	6811P	30.5	\$250,045	RUE	\$5,946	9VM
1250	14100	6813P	30.5	\$249,460	RU	6813P	30.5	\$286,878	RUE	\$6,556	9VM
1500	14100	6813P	30.5	\$289,369	RU	6813P	30.5	\$332,777	RUE	\$7,608	9VM
1750	14100	8011PH	42	\$329,279	RU	8011PH~	42	\$378,671	RUE	\$8,653	9VM
2000	13500	9606PH	42	\$369,197	RU	9606PH	42	\$424,575	RUE	\$9,892	9VM
2250	13500	9606PH	42	\$405,354	RU	9606PH	42	\$466,160	RUE	\$11,099	9VM
2500	13500	9607PH	42	\$445,930	RU	9607PH	42	\$512,819	RUE	\$12,453	9VM

Momentary Upthrust Capacity is 30% of Standard High Thrust Design
~ Not For WPII Enclosure
• NRR = Non-Reverse Ratchet SRC= Self Release Coupling

See Page M-83 For Available And Alternate BD Dimensions



Three Phase Modifiable Motors
Vertical HOLLOSHAFT®
High Thrust - “P” Base
Weather Protected Type I (WPI)
10 Pole, 720 RPM



APPLICATIONS:

For use on Turbine, Mix Flow and Propeller Pumps

FEATURES:

- * Class F Insulation, Class B Rise at Full Load (Sine Wave Power)
- * 1.15 Service Factor (Sine Wave Power)
- * Maximum 40 Deg. C. Ambient, 3,300 Feet Altitude
- * NEMA Design “B”
- * 3 Phase 60 Hz

4000 Volt

HP	Down Thrust (lbs) (#)	Standard Efficient				Premium Efficient				NRR List Adder	Disc. Sym
		Frame	BD (in)	SRC List	Type	Frame	BD (in)	SRC List	Type		
150	13000	5008P	24.5	\$71,324	RU	5008P	24.5	\$82,021	RUE	\$2,439	9VM
200	14100	5012P	24.5	\$81,101	RU	5012P	24.5	\$93,265	RUE	\$2,439	9VM
250	14100	5012P	24.5	\$84,730	RU	5012P	24.5	\$97,439	RUE	\$2,671	9VM
300	14100	5012P	24.5	\$97,601	RU	5012P	24.5	\$112,239	RUE	\$2,721	9VM
350	14100	5012P	24.5	\$114,972	RU	5012P	24.5	\$132,216	RUE	\$3,070	9VM
400	16300	5813P	30.5	\$133,739	RU	5813P	30.5	\$153,800	RUE	\$3,331	9VM
450	16300	5813P	30.5	\$148,075	RU	5813P	30.5	\$170,289	RUE	\$3,700	9VM
500	16300	5813P	30.5	\$151,667	RU	5813P	30.5	\$174,415	RUE	\$3,793	9VM
600	16300	5813P	30.5	\$182,723	RU	5813P	30.5	\$210,131	RUE	\$4,568	9VM
700	16300	5813P	30.5	\$185,939	RU	5813P	30.5	\$213,829	RUE	\$4,577	9VM
800	16300	5813P	30.5	\$202,836	RU	5813P	30.5	\$233,261	RUE	\$4,948	9VM
900	14100	6810P	30.5	\$221,488	RU	6810P	30.5	\$254,709	RUE	\$5,326	9VM
1000	14100	6811P	30.5	\$237,754	RU	6811P	30.5	\$273,415	RUE	\$5,946	9VM
1250	14100	6813P	30.5	\$271,934	RU	6813P	30.5	\$312,723	RUE	\$6,556	9VM
1500	14100	6813P	30.5	\$308,920	RU	6813P	30.5	\$355,258	RUE	\$7,608	9VM
1750	13500	9606PH	42	\$351,528	RU	9606PH	42	\$404,258	RUE	\$8,653	9VM
2000	13500	9606PH	42	\$395,681	RU	9606PH	42	\$455,033	RUE	\$9,892	9VM
2250	13500	9607PH	42	\$443,951	RU	9607PH	42	\$510,542	RUE	\$11,099	9VM
2500	13500	9608PH	42	\$498,108	RU	9608PH	42	\$572,824	RUE	\$12,453	9VM

Momentary Upthrust Capacity is 30% of Standard High Thrust Design
 ~ Not For WP11 Enclosure
 • NRR = Non-Reverse Ratchet SRC= Self Release Coupling

See Page M-83 For Available And Alternate BD Dimensions



Three Phase Modifiable Motors
Vertical HOLLOSHAFT®
High Thrust - “P” Base
Weather Protected Type I (WPI)
12 Pole, 600 RPM



APPLICATIONS:

For use on Turbine, Mix Flow and Propeller Pumps

FEATURES:

- * Class F Insulation, Class B Rise at Full Load (Since Wave Power)
- * NEMA Design “B”
- * 1.15 Service Factor (Sine Wave Power)
- * 3 Phase 60 Hz
- * Maximum 40 Deg. C. Ambient, 3,300 Feet Altitude

460 or 575 Volt

HP	Down Thrust (lbs) (#)	Standard Efficient			Premium Efficient			NRR List Adder	Disc. Sym
		Frame	SRC List	Type	Frame	SRC List	Type		
10	8500	326TP	\$7,467	RU	326TP	\$8,939	RUS	\$674	7VM
15	8500	364TP	\$9,507	RU	364TP	\$11,479	RUS	\$857	7VM
20	8500	365TP	\$11,141	RU	365TP	\$13,336	RUS	\$1,002	7VM
25	9900	404TP	\$12,836	RU	404TP	\$15,364	RUS	\$1,155	7VM
30	9900	405TP	\$14,397	RU	405TP	\$17,232	RUS	\$1,293	7VM
40	14400	H444TP	\$17,070	RU	H444TP	\$20,434	RUS	\$1,305	7VM
50	14400	H445TP	\$19,934	RU	H445TP	\$23,859	RUS	\$1,526	7VM
60	14400	447TP@	\$29,237	RU	447TP@	\$33,329	RUS	\$1,789	7VM
75	14400	447TP@	\$34,467	RU	447TP@	\$39,385	RUS	\$1,803	7VM
100	13600	449TP@	\$43,293	RU	449TP@	\$49,507	RUS	\$1,901	9VM
125	13600	449TP@	\$52,007	RU	449TP@	\$59,514	RUS	\$1,901	9VM
150	13600	5008P	\$59,777	RU	5008P	\$68,406	RUE	\$2,190	9VM
200	15100	5012P	\$75,629	RU	5012P	\$86,587	RUE	\$2,202	9VM
250	15100	5012P	\$77,331	RU	5012P	\$88,547	RUE	\$2,225	9VM
300	15100	5012P	\$89,977	RU	5012P	\$103,096	RUE	\$2,512	9VM
350	17300	5813P	\$122,765	RU	5813P	\$141,181	RUE	\$2,948	9VM
400	17300	5813P	\$139,857	RU	5813P	\$160,833	RUE	\$3,364	9VM
450	17300	5813P	\$154,615	RU	5813P	\$177,808	RUE	\$3,718	9VM
500	17300	5813P	\$171,516	RU	5813P	\$197,244	RUE	\$4,397	9VM

Momentary Upthrust Capacity is 30% of Standard High Thrust Design
+ 15,100 Lbs. Downthrust for 5012 Frame
@Contact your Nidec Motor Corporation Technical Representative for WPII frame size confirmation prior to quoting.
• NRR = Non-Reverse Ratchet SRC= Self Release Coupling

See Page M-83 For Available And Alternate BD Dimensions



Three Phase Modifiable Motors
Vertical HOLLOSHAFT®
High Thrust - "P" Base
Weather Protected Type I (WPI)
12 Pole, 600 RPM



APPLICATIONS:

For use on Turbine, Mix Flow and Propeller Pumps

FEATURES:

- * Class F Insulation, Class B Rise at Full Load (Sine Wave Power)
- * 1.00 Service Factor (Sine Wave Power) ◆
- * Maximum 40 Deg. C. Ambient, 3,300 Feet Altitude
- * NEMA Design "B"
- * 3 Phase 60 Hz

2300 Volt*

HP	Down Thrust (lbs) (#)	Standard Efficient				Premium Efficient				NRR List Adder	Disc. Sym
		Frame	BD (in)	SRC List	Type	Frame	BD (in)	SRC List	Type		
200	15100	5012P	24.5	\$83,845	RU	5012P	24.5	\$96,420	RUE	\$2,096	9VM
250	15100	5012P	24.5	\$107,946	RU	5012P	24.5	\$124,138	RUE	\$2,700	9VM
300	17300	5813P	30.5	\$129,716	RU	5813P	30.5	\$149,174	RUE	\$3,242	9VM
350	17300	5813P	30.5	\$139,474	RU	5813P	30.5	\$160,397	RUE	\$3,486	9VM
400	17300	5813P	30.5	\$149,944	RU	5813P	30.5	\$172,437	RUE	\$3,751	9VM
450	17300	5813P	30.5	\$180,540	RU	5813P	30.5	\$207,620	RUE	\$4,514	9VM
500	17300	5813P	30.5	\$194,131	RU	5813P	30.5	\$223,251	RUE	\$4,854	9VM
600	15000	6810P	30.5	\$211,164	RU	6810P	30.5	\$242,840	RUE	\$5,279	9VM
700	15000	6810P	30.5	\$230,117	RU	6810P	30.5	\$264,636	RUE	\$5,754	9VM
800	15000	6811P	30.5	\$248,786	RU	6811P	30.5	\$286,103	RUE	\$6,221	9VM
900	15000	6811P	30.5	\$268,660	RU	6811P	30.5	\$308,958	RUE	\$6,716	9VM
1000	15000	6813P	30.5	\$290,488	RU	6813P	30.5	\$334,061	RUE	\$7,263	9VM
1250	15000	6813P	30.5	\$322,789	RU	6813P	30.5	\$371,207	RUE	\$8,070	9VM
1500	14700	9607PH	42	\$364,786	RU	9607PH	42	\$419,505	RUE	\$9,120	9VM

- # Momentary Upthrust Capacity is 30% of Standard High Thrust Design
- ◆ Make Adder for 1.15 Service Factor if Desired
- * Make Special Voltage Adder for 4000 Volts
- NRR = Non-Reverse Ratchet SRC= Self Release Coupling

See Page M-83 For Available And Alternate BD Dimensions



Three Phase Modifiable Motors
Vertical HOLLOSHAFT®
High Thrust - "P" Base
Weather Protected Type I (WPI)
14 Pole, 514 RPM

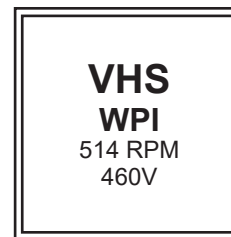

APPLICATIONS:

For use on Turbine, Mix Flow and Propeller Pumps

FEATURES:

- * Class F Insulation, Class B Rise at Full Load (Sine Wave Power)
- * 1.15 Service Factor (Sine Wave Power)
- * Maximum 40 Deg. C. Ambient, 3,300 Feet Altitude
- * NEMA Design "B"
- * 3 Phase 60 Hz

460 or 575 Volt

HP	Down Thrust (lbs) (#)	Standard Efficient				Premium Efficient				NRR List Adder	Disc. Sym
		Frame	BD (in)	SRC List	Type	Frame	BD (in)	SRC List	Type		
100	14200	5008P	24.5	\$73,106	RU	5008P	24.5	\$84,070	RUE	\$1,408	9VM
125	16000	5012P	24.5	\$77,404	RU	5012P	24.5	\$89,014	RUE	\$1,657	9VM
150	16000	5012P	24.5	\$84,761	RU	5012P	24.5	\$97,406	RUE	\$1,887	9VM
200	16000	5012P	24.5	\$96,714	RU	5012P	24.5	\$110,866	RUE	\$2,418	9VM
250	18500	5813P	30.5	\$106,310	RU	5813P	30.5	\$122,254	RUE	\$2,561	9VM
300	18500	5813P	30.5	\$117,261	RU	5813P	30.5	\$134,420	RUE	\$2,932	9VM
350	18500	5813P	30.5	\$139,401	RU	5813P	30.5	\$160,312	RUE	\$3,298	9VM
400	18500	5813P	30.5	\$153,340	RU	5813P	30.5	\$176,340	RUE	\$3,653	9VM
450	18500	5813P	30.5	\$168,671	RU	5813P	30.5	\$193,974	RUE	\$3,979	9VM
500	16000	6810P	30.5	\$185,538	RU	6810P	30.5	\$213,366	RUE	\$4,305	9VM

Momentary Upthrust Capacity is 30% of Standard High Thrust Design
 • NRR = Non-Reverse Ratchet SRC= Self Release Coupling

See Page M-83 For Available And Alternate BD Dimensions



Three Phase Modifiable Motors
Vertical HOLLOSHAFT®
High Thrust - "P" Base
Weather Protected Type I (WPI)
14 Pole, 514 RPM



APPLICATIONS:

For use on Turbine, Mix Flow and Propeller Pumps

FEATURES:

- * Class F Insulation, Class B Rise at Full Load (Sine Wave Power)
- * 1.0 Service Factor (Sine Wave Power) ♦
- * Maximum 40 Deg. C. Ambient, 3,300 Feet Altitude
- * NEMA Design "B"
- * 3 Phase 60 Hz

2300 Volt*

HP	Down Thrust (lbs) (#)	Standard Efficient				Premium Efficient				NRR List Adder	Disc. Sym
		Frame	BD (in)	SRC List	Type	Frame	BD (in)	SRC List	Type		
200	16000	5012P	24.5	\$136,176	RU	5012P	24.5	\$156,603	RUE	\$3,404	9VM
250	18500	5813P	30.5	\$143,345	RU	5813P	30.5	\$164,845	RUE	\$3,582	9VM
300	18500	5813P	30.5	\$160,488	RU	5813P	30.5	\$184,561	RUE	\$4,012	9VM
350	18500	5813P	30.5	\$176,491	RU	5813P	30.5	\$202,965	RUE	\$4,413	9VM
400	18500	5813P	30.5	\$192,491	RU	5813P	30.5	\$221,364	RUE	\$4,812	9VM
450	18500	5813P	30.5	\$208,488	RU	5813P	30.5	\$239,763	RUE	\$5,211	9VM
500	16000	6810P	30.5	\$222,772	RU	6810P	30.5	\$256,188	RUE	\$5,570	9VM
600	16000	6810P	30.5	\$243,014	RU	6810P	30.5	\$279,467	RUE	\$6,075	9VM
700	16000	6811P	30.5	\$264,897	RU	6811P	30.5	\$304,631	RUE	\$6,622	9VM
800	16000	6811P	30.5	\$293,873	RU	6811P	30.5	\$337,953	RUE	\$7,347	9VM
900	16000	6813P	30.5	\$318,190	RU	6813P	30.5	\$365,918	RUE	\$7,955	9VM
1000	16000	6813P	30.5	\$348,779	RU	6813P	30.5	\$401,099	RUE	\$8,721	9VM
1250	15800	9606PH	42	\$396,012	RU	9606PH	42	\$455,413	RUE	\$9,901	9VM
1500	15800	9608PH	42	\$430,448	RU	9608PH	42	\$495,019	RUE	\$10,500	9VM

- # Momentary Upthrust Capacity is 30% of Standard High Thrust Design
- ♦ Make Adder for 1.15 Service Factor if Desired
- * Make Special Voltage Adder For 4000 Volts
- NRR = Non-Reverse Ratchet SRC= Self Release Coupling

See Page M-83 For Available And Alternate BD Dimensions



Three Phase Modifiable Motors
Vertical HOLLOSHAFT®
High Thrust - "P" Base
Weather Protected Type I (WPI)
16 Pole, 450 RPM

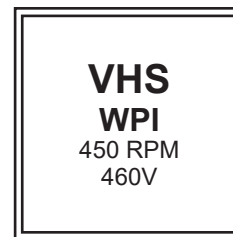

APPLICATIONS:

For use on Turbine, Mix Flow and Propeller Pumps

FEATURES:

- * Class F Insulation, Class B Rise at Full Load (Sine Wave Power)
- * 1.15 Service Factor (Sine Wave Power)
- * Maximum 40 Deg. C. Ambient, 3,300 Feet Altitude
- * NEMA Design "B"
- * 3 Phase 60 Hz

460 or 575 Volt

HP	Down Thrust (lbs) (#)	Standard Efficient				Premium Efficient				NRR List Adder	Disc. Sym
		Frame	BD (in)	SRC List	Type	Frame	BD (in)	SRC List	Type		
100	16600	5012P	24.5	\$81,840	RU	5012P	24.5	\$94,117	RUE	\$2,045	9VM
125	16600	5012P	24.5	\$97,420	RU	5012P	24.5	\$112,033	RUE	\$2,437	9VM
150	16600	5012P	24.5	\$113,850	RU	5012P	24.5	\$130,927	RUE	\$2,847	9VM
200	19500	5813P	30.5	\$146,148	RU	5813P	30.5	\$168,070	RUE	\$3,653	9VM
250	19500	5813P	30.5	\$148,716	RU	5813P	30.5	\$171,021	RUE	\$3,718	9VM
300	19500	5813P	30.5	\$170,183	RU	5813P	30.5	\$195,707	RUE	\$4,256	9VM
350	19500	5813P	30.5	\$191,646	RU	5813P	30.5	\$220,394	RUE	\$4,791	9VM
400	17000	6810P	30.5	\$210,810	RU	6810P	30.5	\$242,432	RUE	\$5,270	9VM
450	17000	6810P	30.5	\$229,986	RU	6810P	30.5	\$264,472	RUE	\$5,749	9VM
500	17000	6811P	30.5	\$250,049	RU	6811P	30.5	\$287,559	RUE	\$6,251	9VM

Momentary Upthrust Capacity is 30% of Standard High Thrust Design
 * NRR = Non-Reverse Ratchet SRC = Self Release Coupling

See Page M-83 For Available And Alternate BD Dimensions



Three Phase Modifiable Motors
Vertical HOLLOSHAFT®
High Thrust - "P" Base
Weather Protected Type I (WPI)
16 Pole, 450 RPM



APPLICATIONS:

For use on Turbine, Mix Flow and Propeller Pumps

FEATURES:

- * Class F Insulation, Class B Rise at Full Load (Sine Wave Power)
- * 1.0 Service Factor (Sine Wave Power)◆
- * Maximum 40 Deg. C. Ambient, 3,300 Feet Altitude
- * NEMA Design "B"
- * 3 Phase 60 Hz

2300 Volt*

HP	Down Thrust (lbs) (#)	Standard Efficient				Premium Efficient				NRR List Adder	Disc. Sym
		Frame	BD (in)	SRC List	Type	Frame	BD (in)	SRC List	Type		
250	19500	5813P	30.5	\$169,643	RU	5813P	30.5	\$195,089	RUE	\$4,239	9VM
300	19500	5813P	30.5	\$190,190	RU	5813P	30.5	\$218,718	RUE	\$4,754	9VM
350	19500	5813P	30.5	\$208,629	RU	5813P	30.5	\$239,925	RUE	\$5,218	9VM
400	17000	6810P	30.5	\$226,782	RU	6810P	30.5	\$260,798	RUE	\$5,669	9VM
450	17000	6810P	30.5	\$246,359	RU	6810P	30.5	\$283,312	RUE	\$6,481	9VM
500	17000	6811P	30.5	\$263,472	RU	6811P	30.5	\$302,993	RUE	\$6,587	9VM
600	17000	6811P	30.5	\$289,913	RU	6811P	30.5	\$333,399	RUE	\$7,249	9VM
700	17000	6813P	30.5	\$306,904	RU	6813P	30.5	\$352,941	RUE	\$7,674	9VM
800	16800	9603PH	42	\$341,094	RU	9603PH	42	\$392,261	RUE	\$8,528	9VM
900	16800	9603PH	42	\$383,739	RU	9603PH	42	\$441,298	RUE	\$9,592	9VM

Momentary Upthrust Capacity is 30% of Standard High Thrust Design

◆Make Adder for 1.15 Service Factor if Desired

* Make Special Voltage Adder for 4000 Volts

• NRR = Non-Reverse Ratchet SRC= Self Release Coupling

See Page M-83 For Available And Alternate BD Dimensions



Three Phase Modifiable Motors
Vertical HOLLOSHAFT®
High Thrust - “P” Base
Weather Protected Type I (WPI)
18 Pole, 400 RPM



APPLICATIONS:

For use on Turbine, Mix Flow and Propeller Pumps

FEATURES:

- * Class F Insulation, Class B Rise at Full Load (Sine Wave Power)
- * 1.15 Service Factor (Sine Wave Power)
- * Maximum 40 Deg. C. Ambient, 3,300 Feet Altitude
- * NEMA Design “B”
- * 3 Phase 60 Hz

460 or 575 Volt

HP	Down Thrust (lbs) (#)	Standard Efficient				Premium Efficient				NRR List Adder	Disc. Sym
		Frame	BD (in)	SRC List	Type	Frame	BD (in)	SRC List	Type		
250	20300	5813P	30.5	\$206,317	RU	5813P	30.5	\$237,265	RUE	\$4,644	9VM
300	20300	5813P	30.5	\$229,178	RU	5813P	30.5	\$263,556	RUE	\$5,157	9VM
350	18000	6810P	30.5	\$249,751	RU	6810P	30.5	\$287,214	RUE	\$5,620	9VM
400	18000	6810P	30.5	\$271,045	RU	6810P	30.5	\$311,702	RUE	\$6,098	9VM
450	18000	6811P	30.5	\$289,869	RU	6811P	30.5	\$333,352	RUE	\$6,524	9VM
500	18000	6813P	30.5	\$305,751	RU	6813P	30.5	\$351,617	RUE	\$6,879	9VM
600	18000	6813P	30.5	\$339,638	RU	6813P	30.5	\$390,587	RUE	\$7,456	9VM
700	17700	9606PH	42	\$360,423	RU	9606PH	42	\$414,486	RUE	\$8,111	9VM
800	17700	9607PH	42	\$380,847	RU	9607PH	42	\$437,977	RUE	\$8,569	9VM

Momentary Upthrust Capacity is 30% of Standard High Thrust Design
 • NRR = Non-Reverse Ratchet SRC= Self Release Coupling

See Page M-83 For Available And Alternate BD Dimensions



Three Phase Modifiable Motors
Vertical HOLLOSHAFT®
High Thrust - "P" Base
Weather Protected Type I (WPI)
18 Pole, 400 RPM



APPLICATIONS:

For use on Turbine, Mix Flow and Propeller Pumps

FEATURES:

- * Class F Insulation, Class B Rise at Full Load (Sine Wave Power)
- * 1.0 Service Factor (Sine Wave Power) ♦
- * Maximum 40 Deg. C. Ambient, 3,300 Feet Altitude
- * NEMA Design "B"
- * 3 Phase 60 Hz

2300 Volt*

HP	Down Thrust (lbs) (#)	Standard Efficient				Premium Efficient				NRR List Adder	Disc. Sym
		Frame	BD (in)	SRC List	Type	Frame	BD (in)	SRC List	Type		
250	20300	5813P	30.5	\$206,317	RU	5813P	30.5	\$237,265	RUE	\$5,160	9VM
300	20300	5813P	30.5	\$229,178	RU	5813P	30.5	\$263,556	RUE	\$5,730	9VM
350	18000	6810P	30.5	\$249,751	RU	6810P	30.5	\$287,214	RUE	\$6,244	9VM
400	18000	6810P	30.5	\$271,045	RU	6810P	30.5	\$311,702	RUE	\$6,775	9VM
450	18000	6811P	30.5	\$289,869	RU	6811P	30.5	\$333,352	RUE	\$7,249	9VM
500	18000	6813P	30.5	\$305,751	RU	6813P	30.5	\$351,617	RUE	\$7,643	9VM
600	18000	6813P	30.5	\$339,638	RU	6813P	30.5	\$390,587	RUE	\$8,284	9VM
700	17700	9606PH	42	\$360,423	RU	9606PH	42	\$414,486	RUE	\$9,012	9VM
800	17700	9607PH	42	\$380,847	RU	9607PH	42	\$437,977	RUE	\$9,521	9VM
900	17700	9607PH	42	\$401,270	RU	9607PH	42	\$461,462	RUE	\$10,033	9VM

Momentary Upthrust Capacity is 30% of Standard High Thrust Design

♦ Make Adder for 1.15 Service Factor if Desired

* Make Special Voltage Adder For 4000 Volts

• NRR = Non-Reverse Ratchet SRC= Self Release Coupling

See Page M-83 For Available And Alternate BD Dimensions



Three Phase Modifiable Motors
Vertical HOLLOSHAFT®
High Thrust - "P" Base
Totally Enclosed Fan Cooled (TEFC)
2 Pole, 3600 RPM

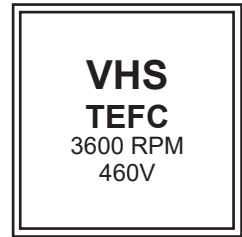

APPLICATIONS:

For use on Turbine, Mix Flow and Propeller Pumps

FEATURES:

- * Class F Insulation, Class B Rise at Full Load (Sine Wave Power)
- * 1.00 Service Factor (Sine Wave Power)
- * Maximum 40 Deg. C. Ambient, 3,300 Feet Altitude
- * NEMA Design "B"
- * 3 Phase 60 Hz

200, 230/460, 575 Volts (&)

HP	Down Thrust (lbs) (#)	Standard Efficient			Energy Efficient			Premium Efficient			NRR List Adder	Adder C.L.1 Grp.D Haz Loc.	Disc. Sym
		Frame	SRC List	Type	Frame	SRC List	Type	Frame	SRC List	Type			
3	2200	182TP	\$2,465	TU	182TP	\$2,820	TUE	182TP	\$2,968	TUS	\$333	\$634	7VM
5	2200	184TP	\$2,488	TU	184TP	\$2,881	TUE	184TP	\$3,033	TUS	\$333	\$634	7VM
7.5	2200	213TP	\$2,667	TU	213TP	\$3,005	TUE	213TP	\$3,164	TUS	\$343	\$822	7VM
10	2200	215TP	\$3,379	TU	215TP	\$3,884	TUE	215TP	\$4,088	TUS	\$352	\$822	7VM
15	2600	254TP	\$3,904	TU	254TP	\$4,387	TUE	254TP	\$4,618	TUS	\$413	\$1,502	7VM
20	2600	256TP	\$4,498	TU	256TP	\$5,006	TUE	256TP	\$5,270	TUS	\$446	\$1,502	7VM
25	2600	284TP	\$4,751	TU	284TP	\$5,576	TUE	284TP	\$5,869	TUS	\$474	\$2,347	7VM
30	2600	286TP	\$5,244	TU	286TP	\$6,030	TUE	286TP	\$6,347	TUS	\$521	\$2,347	7VM
40	3400	324TP	\$7,347	TU	324TP	\$8,259	TUE	324TP	\$8,694	TUS	\$648	\$3,192	7VM
50	3400	326TP	\$8,474	TU	326TP	\$9,299	TUE	326TP	\$9,788	TUS	\$746	\$3,192	7VM
60	3800	364TP	\$11,752	TU	364TP	\$13,204	TUE	364TP	\$13,899	TUS	\$953	\$4,225	7VM
75	3800	365TP	\$13,531	TU	365TP	\$15,677	TUE	365TP	\$16,502	TUS	\$1,192	\$4,225	7VM
100	3900	405TP	\$19,484	TU	405TP	\$21,171	TUE	405TP	\$22,285	TUS	\$1,718	\$4,930	7VM
125	3900	444TP	\$26,643	TU	444TP	\$31,229	TUE	447TP**	\$38,790	TUS	\$2,038	\$6,103	7VM

Momentary Upthrust Capacity is 30% of Standard High Thrust Design & Standard Voltages Thru; 405 Frame & Larger, Single Voltage 460 or 575 Standard
 • NRR = Non-Reverse Ratchet SRC= Self Release Coupling
 ** NEMA Design A

FRAME	STD. BD	ALT. BD	MAX BX	CD
180	10	---	1.001	17.563
210	10	---	1.001	17.563
250	10	12	1.251	22.938
280	10	12-16.5	1.251	26.563
320	16.5	12	1.501	28.500
360	16.5	---	1.501	30.000
400	16.5	20	1.688	39.938
444-5	16.5	20	1.937	42.500

FRAME	STD. BD	ALT. BD	MAX BX	CD
447	16.5	20	1.937	46.000
449	24.5	20	2.501	56.875
5008	24.5	20	2.501	56.500
5807	30.5	24.5	2.750	61.531
5809	30.5	24.5	2.750	68.531
5811	30.5	24.5	2.750	76.531
5812	30.5	36	2.750	83.880
6812	36.0	30.5-42	2.750	83.880

See Page M-84 For Available And Alternate BD Dimensions

* 60Hz 3600, 1800, 1200 & 900 RPM motors comply with U.S. D.O.E.'s Efficiency regulation 10 CFR Section 431 Subpart B – electric motors (See Page M-80 - M-81 for Nominal Efficiency Table)



Three Phase Modifiable Motors
Vertical HOLLOSHAFT®
High Thrust - "P" Base
Totally Enclosed Fan Cooled (TEFC)
4 Pole, 1800 RPM



APPLICATIONS:

For use on Turbine, Mix Flow and Propeller Pumps

FEATURES:

- * Class F Insulation, Class B Rise at Full Load (Sine Wave Power)
- * 1.00 Service Factor (Sine Wave Power)
- * Maximum 40 Deg. C. Ambient, 3,300 Feet Altitude
- * NEMA Design "B"
- * 3 Phase 60 Hz

200, 230/460, 575 Volts (&)

HP	Down Thrust (lbs)(#)	Standard Efficient			Energy Efficient			Premium Efficient			NRR List Adder	Adder C.L.1 Grp. D. Haz. Loc.	Disc. Sym
		Frame	SRC List	Type	Frame	SRC List	Type	Frame	SRC List	Type			
3	2500	182TP	\$2,709	TU	182TP	\$2,945	TUE	182TP	\$3,100	TUS	\$333	\$634	7VM
5	2500	184TP	\$2,768	TU	184TP	\$3,009	TUE	184TP	\$3,167	TUS	\$333	\$634	7VM
7.5	2500	213TP	\$2,888	TU	213TP	\$3,139	TUE	213TP	\$3,304	TUS	\$343	\$822	7VM
10	2500	215TP	\$3,611	TU	215TP	\$4,057	TUE	215TP	\$4,271	TUS	\$352	\$822	7VM
15	3300	254TP	\$4,263	TU	254TP	\$4,680	TUE	254TP	\$4,927	TUS	\$423	\$1,502	7VM
20	3300	256TP	\$4,854	TU	256TP	\$5,227	TUE	256TP	\$5,502	TUS	\$488	\$1,502	7VM
25	3300	284TP	\$5,413	TU	284TP	\$5,939	TUE	284TP	\$6,251	TUS	\$545	\$2,347	7VM
30	3300	286TP	\$6,089	TU	286TP	\$6,563	TUE	286TP	\$6,909	TUS	\$610	\$2,347	7VM
40	4500	324TP	\$7,700	TU	324TP	\$8,394	TUE	324TP	\$8,836	TUS	\$681	\$3,192	7VM
50	4500	326TP	\$9,136	TU	326TP	\$9,722	TUE	326TP	\$10,233	TUS	\$808	\$3,192	7VM
60	5600	364TP	\$11,793	TU	364TP	\$12,681	TUE	364TP	\$13,348	TUS	\$1,000	\$4,225	7VM
75	5600	365TP	\$13,770	TU	365TP	\$14,423	TUE	365TP	\$15,182	TUS	\$1,211	\$4,225	7VM
100	7000	405TP	\$18,554	TU	405TP	\$19,533	TUE	405TP	\$20,561	TUS	\$1,634	\$4,930	7VM
125	9300	444TP	\$24,399	TU	444TP	\$27,699	TUE	444TP	\$29,157	TUS	\$1,869	\$6,103	7VM
150	9300	447TP	\$29,803	TU	447TP	\$32,687	TUE	447TP	\$34,407	TUS	\$2,282	\$7,042	7VM
200	9300	447TP	\$41,653	TU	447TP	\$43,630	TUE	447TP	\$45,926	TUS	\$3,188	\$7,042	7VM
250	8800	449TP	\$56,406	JU	449TP	\$61,623	JU	449TP	\$64,866	JUE	\$1,352	N/A	8VM
	8800	5008P	\$68,981	EU	5008P	\$75,363	EU	5008P	\$79,329	EUE	\$1,352	---	8VM
300	8800	449TP	\$62,660	JU	449TP	\$68,456	JU	449TP	\$72,059	JUE	\$1,512	N/A	8VM
	8800	5008P	\$73,221	EU	5008P	\$79,994	EU	5008P	\$84,204	EUE	\$1,512	---	8VM
350	8800	449TP	\$73,596	JU	449TP	\$80,404	JU	449TP	\$84,636	JUE	\$1,784	N/A	8VM
	8800	5008P	\$84,925	EU	5807P	\$92,781	EU	5807P	\$97,664	EUE	\$1,784	---	8VM
400	9500	5807P	\$83,352	JU	5807P	\$91,061	JU	5807P	\$95,854	JUE	\$1,873	\$11,326	8VM
450	9500	5807P	\$93,638	JU	5807P	\$102,301	JU	5807P	\$107,685	JUE	\$1,873	\$13,465	8VM
500	9500	5809P	\$103,662	JU	5809P	\$113,250	JU	5809P	\$119,211	JUE	\$2,075	\$13,465	8VM
600	9500	5811P	\$149,812	JU	---	---	---	5811P	\$172,284	JUE	\$2,408	\$22,007	8VM
700	9300	5812P	\$169,286	JU	---	---	---	5812P	\$194,678	JUE	\$2,650	N/A	8VM
800	9300	5812P	\$195,386	JU	---	---	---	5812P	\$224,694	JUE	\$3,045	N/A	8VM

Momentary Upthrust Capacity is 30% of Standard High Thrust Design
 & Standard Voltages Thru 404 Frame; 405 Frame & Larger, Single Voltage 460 or 575 standard
 • NRR = Non-Reverse Ratchet SRC= Self Release Coupling

See Page M-84 For Available And Alternate BD Dimensions

* 60Hz 3600, 1800, 1200 & 900 RPM motors comply with U.S. D.O.E.'s Efficiency regulation 10 CFR Section 431 Subpart B – electric motors (See Page M-80 - M-81 for Nominal Efficiency Table)



† All marks shown within this document are properties of their respective owners.

Three Phase Modifiable Motors
Vertical HOLLOSHAFT®
High Thrust - "P" Base
Totally Enclosed Fan Cooled (TEFC)
4 Pole, 1800 RPM



APPLICATIONS:

For use on Turbine, Mix Flow and Propeller Pumps

FEATURES:

- * Class F Insulation, Class B Rise at Full Load (Sine Wave Power)
- * 1.00 Service Factor (Sine Wave Power)
- * Maximum 40 Deg. C. Ambient, 3,300 Feet Altitude

- * NEMA Design "B"
- * 3 Phase 60 Hz

2300 Volt

HP	Down Thrust (lbs) (#)	Standard Efficient				Premium Efficient				NRR List Adder	Adder C.L.1 Grp. D. Haz. Loc.	Disc. Sym
		Frame	BD (in)	SRC List	Type	Frame	BD(in)	SRC List	Type			
150	8800	449TP	24.5	\$59,493	JU	449TP	24.5	\$68,418	JUE	\$1,387	N/A	8VM
	8800	5008P	24.5	\$66,141	EU	5008P	24.5	\$76,061	EUE	\$1,387	---	8VM
200	8800	449TP	24.5	\$65,793	JU	449TP	24.5	\$75,662	JUE	\$1,535	N/A	8VM
	8800	5008P	24.5	\$73,462	EU	5008P	24.5	\$84,481	EUE	\$1,535	---	8VM
250	8800	449TP	24.5	\$71,380	JU	449TP	24.5	\$82,087	JUE	\$1,723	N/A	8VM
	8800	5008P	24.5	\$82,049	EU	5008P	24.5	\$94,357	EUE	\$1,723	---	8VM
300	9500	5807P	30.5	\$80,418	JU	5807P	30.5	\$92,481	JUE	\$1,854	\$10,563	8VM
350	9500	5807P	30.5	\$92,143	JU	5807P	30.5	\$105,965	JUE	\$1,854	\$13,469	8VM
400	9500	5807P	30.5	\$102,477	JU	5809P	30.5	\$117,847	JUE	\$2,061	\$13,469	8VM
450	9500	5809P	30.5	\$114,331	JU	5809P	30.5	\$131,481	JUE	\$2,286	\$19,484	8VM
500	9500	5811P	30.5	\$130,575	JU	5811P	30.5	\$150,162	JUE	\$2,627	\$19,484	8VM
600	9500	5811P	30.5	\$156,690	JU	5811P	30.5	\$180,195	JUE	\$3,134	\$22,007	8VM
700	9300	5812P	30.5	\$182,805	JU	5812P	30.5	\$210,225	JUE	\$4,573	N/A	8VM
800	9300	5812P	30.5	\$195,386	JU	5812P	30.5	\$224,694	JUE	\$5,170	N/A	8VM
900	9300	5812P	30.5	\$207,239	JU	5812P	30.5	\$238,325	JUE	\$5,484	N/A	8VM
1000	9300	5812P	30.5	\$218,474	JU	5812P	30.5	\$251,245	JUE	\$5,780	N/A	8VM
1250**	9300	5812P	30.5	\$244,226	JU	5812P	30.5	\$280,860	JUE	\$6,462	N/A	8VM
1500	10900	6812PA	36	\$266,206	JU	6812PA	36	\$306,137	JUE	\$6,850	N/A	9VM
1750	10900	6812PA	36	\$290,164	JU	6812PA	36	\$333,689	JUE	\$7,261	N/A	9VM
2000**	10900	6812PA	36	\$316,279	JU	6812PA	36	\$363,721	JUE	\$7,696	N/A	9VM

4160 Volt

HP	Down Thrust (lbs) (#)	Standard Efficient				Premium Efficient				NRR List Adder	Adder C.L.1 Grp. D. Haz. Loc.	Disc. Sym
		Frame	BD (in)	SRC List	Type	Frame	BD(in)	SRC List	Type			
150	8800	449TP	24.5	\$63,657	JU	449TP	24.5	\$73,207	JUE	\$1,387	N/A	8VM
	8800	5008P	24.5	\$70,305	EU	5008P	24.5	\$80,852	EUE	\$1,387	---	8VM
200	8800	449TP	24.5	\$70,397	JU	449TP	24.5	\$80,960	JUE	\$1,535	N/A	8VM
	8800	5008P	24.5	\$78,066	EU	5008P	24.5	\$89,775	EUE	\$1,535	---	8VM
250	9500	5807P	30.5	\$76,549	JU	5807P	30.5	\$88,033	JUE	\$1,723	N/A	8VM
	9500	5807P	30.5	\$87,218	EU	5807P	30.5	\$100,300	EUE	\$1,723	---	8VM
300	9500	5807P	30.5	\$86,232	JU	5807P	30.5	\$99,167	JUE	\$1,854	\$10,563	8VM
350	9500	5807P	30.5	\$98,845	JU	5807P	30.5	\$113,671	JUE	\$1,854	\$13,469	8VM
400	9500	5809P	30.5	\$108,439	JU	5809P	30.5	\$124,704	JUE	\$2,061	\$13,469	8VM
450	9500	5809P	30.5	\$120,986	JU	5811P	30.5	\$139,134	JUE	\$2,286	\$19,484	8VM
500	9500	5811P	30.5	\$138,176	JU	5811P	30.5	\$158,901	JUE	\$2,627	\$19,484	8VM
600	9500	5811P	30.5	\$165,810	JU	5811P	30.5	\$190,681	JUE	\$3,134	\$22,007	8VM
700	9300	5812P	30.5	\$193,446	JU	5812P	30.5	\$222,462	JUE	\$4,573	N/A	8VM
800	9300	5812P	30.5	\$205,155	JU	5812P	30.5	\$235,929	JUE	\$5,170	N/A	8VM
900	9300	5812P	30.5	\$217,600	JU	5812P	30.5	\$250,241	JUE	\$5,484	N/A	8VM
1000	9300	5812P	30.5	\$229,398	JU	5812P	30.5	\$263,807	JUE	\$5,780	N/A	8VM
1250**	9300	5812P	30.5	\$256,437	JU	5812P	30.5	\$294,903	JUE	\$6,462	N/A	8VM
1500	10900	6812PA	36	\$279,516	JU	6812PA	36	\$321,443	JUE	\$6,850	N/A	9VM
1750	10900	6812PA	36	\$304,672	JU	6812PA	36	\$350,373	JUE	\$7,261	N/A	9VM
2000**	10900	6812PA	36	\$332,093	JU	6812PA	36	\$381,907	JUE	\$7,696	N/A	9VM

Momentary Upthrust Capacity is 30% of Standard High Thrust Design

** Class B rise by embedded detector at 1.0 Service Factor. Price includes 100 ohm winding Resistance Temperature Detectors

• NRR = Non-Reverse Ratchet SRC= Self Release Coupling

See Page M-84 For Available And Alternate BD Dimensions



† All marks shown within this document are properties of their respective owners.

Three Phase Modifiable Motors
Vertical HOLLOSHAFT®
High Thrust - "P" Base
Totally Enclosed Fan Cooled (TEFC)
6 Pole, 1200 RPM



APPLICATIONS:

For use on Turbine, Mix Flow and Propeller Pumps

FEATURES:

- * Class F Insulation, Class B Rise at Full Load (Sine Wave Power)
- * 1.00 Service Factor (Sine Wave Power)
- * Maximum 40 Deg. C. Ambient, 3,300 Feet Altitude
- * NEMA Design "B"
- * 3 Phase 60 Hz

200, 230/460, 575 Volts (&)

HP	Down Thrust (lbs)(#)	Standard Efficient			Energy Efficient			Premium Efficient			NRR List Adder	Adder C.L.1 Grp. D. Haz. Loc.	Disc. Sym
		Frame	SRC List	Type	Frame	SRC List	Type	Frame	SRC List	Type			
2	2900	184TP	\$2,704	TU	184TP	\$2,953	TUE	184TP	\$3,101	TUS	\$286	\$634	7VM
3	2900	213TP	\$2,934	TU	213TP	\$3,418	TUE	213TP	\$3,589	TUS	\$291	\$822	7VM
5	2900	215TP	\$3,634	TU	215TP	\$4,369	TUE	215TP	\$4,587	TUS	\$394	\$822	7VM
7.5	3800	254TP	\$4,329	TU	254TP	\$5,063	TUE	254TP	\$5,317	TUS	\$469	\$1,502	7VM
10	3800	256TP	\$4,887	TU	256TP	\$5,756	TUE	256TP	\$6,045	TUS	\$488	\$1,502	7VM
15	3800	284TP	\$5,700	TU	284TP	\$6,822	TUE	284TP	\$7,162	TUS	\$568	\$2,347	7VM
20	3800	286TP	\$6,930	TU	286TP	\$8,052	TUE	286TP	\$8,455	TUS	\$690	\$2,347	7VM
25	5100	324TP	\$8,606	TU	324TP	\$10,073	TUE	324TP	\$10,577	TUS	\$761	\$3,192	7VM
30	5100	326TP	\$9,826	TU	326TP	\$11,293	TUE	326TP	\$11,859	TUS	\$864	\$3,192	7VM
40	6400	364TP	\$12,864	TU	364TP	\$15,467	TUE	364TP	\$16,239	TUS	\$1,136	\$4,225	7VM
50	6400	365TP	\$15,169	TU	365TP	\$17,772	TUE	365TP	\$18,662	TUS	\$1,338	\$4,225	7VM
60	8000	404TP	\$18,474	TU	404TP	\$22,092	TUE	404TP	\$23,197	TUS	\$1,634	\$4,930	7VM
75	8000	405TP	\$21,732	TU	405TP	\$27,263	TUE	405TP	\$28,627	TUS	\$1,915	\$4,930	7VM
100	10600	444TP	\$28,300	TU	444TP	\$33,831	TUE	444TP	\$35,523	TUS	\$2,925	\$6,103	7VM
125	10600	447TP	\$35,488	TU	447TP	\$41,019	TUE	447TP	\$43,068	TUS	\$3,371	\$7,042	7VM
150	10600	447TP	\$44,094	TU	447TP	\$50,275	TUE	447TP	\$52,789	TUS	\$3,371	\$7,042	7VM
200	10000	449TP	\$71,305	JU	449TP	\$77,900	JU	449TP	\$82,000	JUE	\$1,967	N/A	8VM
	10000	5008P	\$81,869	EU	5008P	\$89,441	EU	5008P	\$94,148	EUE	\$1,967	---	8VM
250	10000	449TP	\$75,354	JU	449TP	\$82,324	JU	449TP	\$86,657	JUE	\$2,077	N/A	8VM
	10000	5008P	\$87,477	EU	5008P	\$95,569	EU	5008P	\$100,599	EUE	\$2,077	---	8VM
300	10000	449TP	\$89,925	JU	449TP	\$98,242	JU	449TP	\$103,413	JUE	\$2,077	N/A	8VM
	11000	5807P	\$101,251	EU	5807P	\$110,617	EU	5807P	\$116,439	EUE	\$2,077	---	8VM
350	11000	5807P	\$104,754	JU	5807P	\$114,444	JU	5807P	\$120,467	JUE	\$2,096	\$13,469	8VM
400	11000	5807P	\$120,305	JU	5807P	\$131,434	JU	5807P	\$138,352	JUE	\$2,406	\$13,469	8VM
450	11000	5809P	\$135,343	JU	5809P	\$147,861	JU	5809P	\$155,643	JUE	\$2,709	\$19,484	8VM
500	11000	5809P	\$150,383	JU	5809P	\$164,292	JU	5809P	\$172,939	JUE	\$3,007	\$19,484	8VM
600	11000	5811P	\$180,458	JU	---	---	---	5811P	\$207,526	JUE	\$3,610	\$22,007	8VM
700	10600	5812P	\$193,883	JU	---	---	---	5812P	\$222,965	JUE	\$3,900	N/A	8VM

Momentary Upthrust Capacity is 30% of Standard High Thrust Design
 & Standard Voltages Thru 404 Frame; 405 Frame & Larger, Single Voltage 460 or 575 is standard
 • NRR = Non-Reverse Ratchet SRC= Self Release Coupling

See Page M-84 For Available And Alternate BD Dimensions

* 60Hz 3600, 1800, 1200 & 900 RPM motors comply with U.S. D.O.E.'s Efficiency regulation 10 CFR Section 431 Subpart B – electric motors (See Page M-80 - M-81 for Nominal Efficiency Table)



† All marks shown within this document are properties of their respective owners.

Three Phase Modifiable Motors
Vertical HOLLSHAFT®
High Thrust - "P" Base
Totally Enclosed Fan Cooled (TEFC)
6 Pole, 1200 RPM

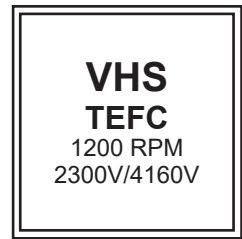

APPLICATIONS:

For use on Turbine, Mix Flow and Propeller Pumps

FEATURES:

- * Class F Insulation, Class B Rise at Full Load (Sine Wave Power)
- * 1.00 Service Factor (Sine Wave Power)
- * Maximum 40 Deg. C. Ambient, 3,300 Feet Altitude
- * NEMA Design "B"
- * 3 Phase 60 Hz

2300 Volts

HP	Down Thrust (lbs) (#)	Standard Efficient				Premium Efficient				NRR List Adder	Adder C.L.1 Grp. D. Haz. Loc.	Disc. Sym
		Frame	BD (in)	SRC List	Type	Frame	BD(in)	SRC List	Type			
125	10000	449TP	24.5	\$66,758	JU	449TP	24.5	\$76,772	JUE	\$2,174	N/A	8VM
	10000	5008P	24.5	\$73,406	EU	5008TP	24.5	\$84,418	EUE	\$2,174	---	8VM
150	10000	449TP	24.5	\$73,169	JU	449TP	24.5	\$84,146	JUE	\$2,174	N/A	8VM
	10000	5008P	24.5	\$79,270	EU	5008TP	24.5	\$91,160	EUE	\$2,174	---	8VM
200	10000	449TP	24.5	\$85,531	JU	449TP	24.5	\$98,359	JUE	\$2,174	N/A	8VM
	10000	5008P	24.5	\$94,737	EU	5008TP	24.5	\$108,948	EUE	\$2,174	---	8VM
250	11000	5807P	30.5	\$95,904	JU	5807P	30.5	\$110,289	JUE	\$2,200	\$11,326	8VM
300	11000	5807P	30.5	\$111,033	JU	5807P	30.5	\$127,688	JUE	\$2,225	\$13,469	8VM
350	11000	5807P	30.5	\$124,965	JU	5807P	30.5	\$143,709	JUE	\$2,261	\$13,469	8VM
400	11000	5809P	30.5	\$140,305	JU	5809P	30.5	\$161,352	JUE	\$2,406	\$19,484	8VM
450	11000	5809P	30.5	\$161,350	JU	5809P	30.5	\$185,552	JUE	\$2,918	\$19,484	8VM
500	11000	5811P	30.5	\$183,939	JU	5811P	30.5	\$211,531	JUE	\$3,324	\$19,484	8VM
600	10600	5812P	30.5	\$211,528	JU	5812P	30.5	\$243,261	JUE	\$3,824	N/A	8VM
700	10600	5812P	30.5	\$224,928	JU	5812P	30.5	\$258,667	JUE	\$5,952	N/A	8VM
800**	10600	5812P	30.5	\$241,438	JU	5812P	30.5	\$277,654	JUE	\$6,388	N/A	8VM
900	13700	6812PA	36	\$254,904	JU	6812PA	36	\$293,140	JUE	\$6,771	N/A	9VM
1000	13700	6812PA	36	\$268,723	JU	6812PA	36	\$309,031	JUE	\$7,178	N/A	9VM
1250	13700	6812PA	36	\$300,397	JU	6812PA	36	\$345,457	JUE	\$7,608	N/A	9VM

4160 Volts

HP	Down Thrust (lbs) (#)	Standard Efficient				Premium Efficient				NRR List Adder	Adder C.L.1 Grp. D. Haz. Loc.	Disc. Sym
		Frame	BD (in)	SRC List	Type	Frame	BD(in)	SRC List	Type			
150	10000	449TP	24.5	\$85,857	JU	449TP	24.5	\$98,735	JUE	\$2,174	N/A	8VM
	10000	5008P	24.5	\$91,944	EU	5008P	24.5	\$105,735	EUE	\$2,174	---	8VM
200	11000	5807P	30.5	\$96,850	JU	5807P	30.5	\$111,378	JUE	\$2,174	N/A	8VM
	11000	5807P	30.5	\$106,054	EU	5807P	30.5	\$121,962	EUE	\$2,174	---	8VM
250	11000	5807P	30.5	\$102,880	JU	5807P	30.5	\$118,310	JUE	\$2,200	\$11,326	8VM
300	11000	5807P	30.5	\$117,495	JU	5807P	30.5	\$135,120	JUE	\$2,225	\$13,469	8VM
350	11000	5807P	30.5	\$132,385	JU	5807P	30.5	\$152,242	JUE	\$2,261	\$13,469	8VM
400	11000	5809P	30.5	\$148,376	JU	5809P	30.5	\$170,631	JUE	\$2,406	\$19,484	8VM
450	11000	5811P	30.5	\$170,629	JU	5811P	30.5	\$196,223	JUE	\$2,918	\$19,484	8VM
500	11000	5811P	30.5	\$194,516	JU	5811P	30.5	\$223,695	JUE	\$3,324	\$19,484	8VM
600	10600	5812P	30.5	\$223,695	JU	5812P	30.5	\$257,249	JUE	\$3,824	N/A	8VM
700	10600	5812P	30.5	\$236,174	JU	5812P	30.5	\$271,600	JUE	\$5,952	N/A	8VM
800**	10600	5812P	30.5	\$253,509	JU	5812P	30.5	\$291,535	JUE	\$6,388	N/A	8VM
900	13700	6812PA	36	\$268,737	JU	6812PA	36	\$309,048	JUE	\$6,771	N/A	9VM
1000	13700	6812PA	36	\$282,159	JU	6812PA	36	\$324,483	JUE	\$7,178	N/A	9VM
1250	13700	6812PA	36	\$315,417	JU	6812PA	36	\$362,730	JUE	\$7,608	N/A	9VM

Momentary Upthrust Capacity is 30% of Standard High Thrust Design

** Class B rise by embedded detector at 1.0 Service Factor. Price includes 100 ohm winding Resistance Temperature Detectors

• NRR = Non-Reverse Ratchet SRC= Self Release Coupling

See Page M-84 For Available And Alternate BD Dimensions



† All marks shown within this document are properties of their respective owners.

Three Phase Modifiable Motors
Vertical HOLLOSHAFT®
High Thrust - "P" Base
Totally Enclosed Fan Cooled (TEFC)
8 Pole, 900 RPM



APPLICATIONS:

For use on Turbine, Mix Flow and Propeller Pumps

FEATURES:

- * Class F Insulation, Class B Rise at Full Load (Sine Wave Power)
- * 1.00 Service Factor (Sine Wave Power)
- * Maximum 40 Deg. C. Ambient, 3,300 Feet Altitude
- * NEMA Design "B"
- * 3 Phase 60 Hz

200, 230/460, 575 Volts (&)

HP	Down Thrust (lbs)(#)	Standard Efficient			Energy Efficient			Premium Efficient			NRR List Adder	Adder C.L.1 Grp. D. Haz. Loc.	Disc. Sym
		Frame	SRC List	Type	Frame	SRC List	Type	Frame	SRC List	Type			
1.5	3200	184TP	\$2,512	TU	184TP	\$2,995	TUE	184TP	\$3,146	TUS	\$286	\$634	7VM
2	3200	213TP	\$2,533	TU	213TP	\$3,268	TUE	213TP	\$3,432	TUS	\$291	\$822	7VM
3	3200	215TP	\$2,878	TU	215TP	\$3,613	TUE	215TP	\$3,793	TUS	\$385	\$822	7VM
5	4200	254TP	\$4,357	TU	254TP	\$5,225	TUE	254TP	\$5,486	TUS	\$469	\$1,502	7VM
7.5	4200	256TP	\$5,019	TU	256TP	\$5,887	TUE	256TP	\$6,181	TUS	\$540	\$1,502	7VM
10	4200	284TP	\$6,207	TU	284TP	\$7,329	TUE	284TP	\$7,695	TUS	\$540	\$2,347	7VM
15	4200	286TP	\$7,061	TU	286TP	\$8,183	TUE	286TP	\$8,592	TUS	\$704	\$2,347	7VM
20	5600	324TP	\$8,915	TU	324TP	\$10,383	TUE	324TP	\$10,901	TUS	\$784	\$3,192	7VM
25	5600	326TP	\$10,263	TU	326TP	\$11,730	TUE	326TP	\$12,317	TUS	\$894	\$3,192	7VM
30	7000	364TP	\$12,343	TU	364TP	\$14,946	TUE	364TP	\$15,692	TUS	\$1,089	\$4,225	7VM
40	7000	365TP	\$14,878	TU	365TP	\$17,481	TUE	365TP	\$18,354	TUS	\$1,310	\$4,225	7VM
50	8800	404TP	\$18,080	TU	404TP	\$21,697	TUE	404TP	\$22,782	TUS	\$1,596	\$4,930	7VM
60	8800	405TP	\$20,859	TU	405TP	\$24,477	TUE	405TP	\$25,700	TUS	\$1,840	\$4,930	7VM
75	11700	444TP	\$26,601	TU	444TP	\$32,131	TUE	444TP	\$33,737	TUS	\$2,033	\$6,103	7VM
100	11700	447TP	\$35,573	TU	447TP	\$41,103	TUE	447TP	\$43,160	TUS	\$2,718	\$7,042	7VM
125	11700	447TP	\$47,455	TU	447TP	\$52,986	TUE	447TP	\$55,636	TUS	\$2,718	\$7,042	7VM
150	11000	449TP	\$72,289	JU	449TP	\$78,974	JU	449TP	\$83,131	JUE	\$1,674	N/A	8VM
	11000	5008P	\$81,972	EU	5008P	\$89,555	EU	5008P	\$94,268	EUE	\$1,674	---	8VM
200	11000	449TP	\$83,101	JU	449TP	\$90,788	JU	449TP	\$95,566	JUE	\$1,674	N/A	8VM
	11000	5008P	\$92,972	EU	5008P	\$101,572	EU	5008P	\$106,918	EUE	\$1,674	---	8VM
250	11000	449TP	\$93,310	JU	449TP	\$101,943	JU	449TP	\$107,308	JUE	\$1,878	N/A	8VM
	12300	5807P	\$104,636	EU	5807P	\$114,314	EU	5807P	\$120,331	EUE	\$1,878	---	8VM
300	12300	5807P	\$110,915	JU	5807P	\$121,176	JU	5807P	\$127,554	JUE	\$2,690	\$13,465	8VM
350	12300	5807P	\$128,873	JU	5807P	\$140,794	JU	5807P	\$148,204	JUE	\$3,143	\$13,465	8VM
400	12300	5809P	\$146,784	JU	5809P	\$160,363	JU	5809P	\$168,803	JUE	\$3,671	\$19,484	8VM
450	12300	5809P	\$161,556	JU	5809P	\$176,500	JU	5809P	\$185,789	JUE	\$4,038	\$19,484	8VM
500	12300	5811P	\$183,392	JU	5811P	\$200,356	JU	5811P	\$210,901	JUE	\$4,587	\$22,007	8VM
600	11700	5812P	\$208,898	JU	---	---	---	5812P	\$240,233	JUE	\$5,153	N/A	8VM
700	15000	6812PA	\$236,054	JU	---	---	---	6812PA	\$271,463	JUE	\$5,563	N/A	9VM
800	15000	6812PA	\$266,741	JU	---	---	---	6812PA	\$306,752	JUE	\$6,146	N/A	9VM

Momentary Upthrust Capacity is 30% of Standard High Thrust Design
 & Standard Voltages Thru 404 Frame; 405 Frame & Larger, Single Voltage 460 or 575 standard
 • NRR = Non-Reverse Ratchet SRC= Self Release Coupling
 * 60Hz 3600, 1800, 1200 & 900 RPM motors comply with U.S. D.O.E.'s Efficiency regulation 10 CFR Section 431 Subpart B – electric motors (See Page M-80 - M-81 for Nominal Efficiency Table)

See Page M-84 For Available And Alternate BD Dimensions



† All marks shown within this document are properties of their respective owners.

Three Phase Modifiable Motors
Vertical HOLLOSHAFT®
High Thrust - "P" Base
Totally Enclosed Fan Cooled (TEFC)
8 Pole, 900 RPM

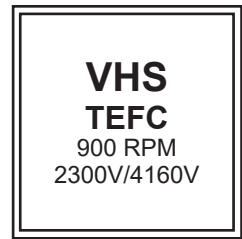

APPLICATIONS:

For use on Turbine, Mix Flow and Propeller Pumps

FEATURES:

- * Class F Insulation, Class B Rise at Full Load (Sine Wave Power)
- * 1.00 Service Factor (Sine Wave Power)
- * Maximum 40 Deg. C. Ambient, 3,300 Feet Altitude
- * NEMA Design "B"
- * 3 Phase 60 Hz

2300 Volts

HP	Down Thrust (lbs) (#)	Standard Efficient				Premium Efficient				NRR List Adder	Adder C.L.1 Grp. D. Haz. Loc.	Disc. Sym
		Frame	BD (in)	SRC List	Type	Frame	BD (in)	SRC List	Type			
125	11000	449TP	24.5	\$77,042	JU	449TP	24.5	\$88,599	JUE	\$1,955	N/A	8VM
	11000	5008P	24.5	\$87,606	EU	5008P	24.5	\$100,746	EUE	\$1,955	---	8VM
150	11000	449TP	24.5	\$85,925	JU	449TP	24.5	\$98,815	JUE	\$2,185	N/A	8VM
	11000	5008P	24.5	\$96,488	EU	5008P	24.5	\$110,962	EUE	\$2,185	---	8VM
200	12300	5807P	30.5	\$106,756	JU	5807P	30.5	\$122,770	JUE	\$2,230	\$13,469	8VM
250	12300	5807P	30.5	\$119,437	JU	5807P	30.5	\$137,352	JUE	\$2,390	\$13,469	8VM
300	12300	5807P	30.5	\$136,068	JU	5807P	30.5	\$156,479	JUE	\$2,721	\$13,469	8VM
350	12300	5809P	30.5	\$154,049	JU	5809P	30.5	\$177,157	JUE	\$3,852	\$19,484	8VM
400	12300	5809P	30.5	\$176,056	JU	5809P	30.5	\$202,465	JUE	\$4,385	\$19,484	8VM
450	12300	5811P	30.5	\$204,667	JU	5811P	30.5	\$235,366	JUE	\$5,117	\$22,007	8VM
500	12300	5811P	30.5	\$227,406	JU	5811P	30.5	\$261,516	JUE	\$5,688	\$22,007	8VM
600	11700	5812P	30.5	\$246,179	JU	5812P	30.5	\$283,106	JUE	\$6,620	N/A	8VM
700	15000	6812PA	36	\$265,415	JU	6812PA	36	\$305,227	JUE	\$7,704	N/A	9VM
800	15000	6812PA	36	\$284,896	JU	6812PA	36	\$327,631	JUE	\$8,937	N/A	9VM
900	15000	6812PA	36	\$300,787	JU	6812PA	36	\$345,905	JUE	\$9,301	N/A	9VM
1000	15000	6812PA	36	\$317,093	JU	6812PA	36	\$364,657	JUE	\$10,417	N/A	9VM

4160 Volts

HP	Down Thrust (lbs) (#)	Standard Efficient				Premium Efficient				NRR List Adder	Adder C.L.1 Grp. D. Haz. Loc.	Disc. Sym
		Frame	BD (in)	SRC List	Type	Frame	BD (in)	SRC List	Type			
150	11000	449TP	24.5	\$101,669	JU	449TP	24.5	\$116,920	JUE	\$2,185	N/A	8VM
	11000	5008P	24.5	\$112,232	EU	5008P	24.5	\$129,068	EUE	\$2,185	---	8VM
200	12300	5807P	30.5	\$127,047	JU	5807P	30.5	\$146,103	JUE	\$2,230	\$13,469	8VM
250	12300	5807P	30.5	\$139,514	JU	5807P	30.5	\$160,441	JUE	\$2,390	\$13,469	8VM
300	12300	5809P	30.5	\$157,019	JU	5809P	30.5	\$180,573	JUE	\$2,721	\$19,484	8VM
350	12300	5809P	30.5	\$177,789	JU	5809P	30.5	\$204,246	JUE	\$3,852	\$19,484	8VM
400	12300	5811P	30.5	\$203,185	JU	5811P	30.5	\$233,664	JUE	\$4,385	\$22,007	8VM
450	12300	5811P	30.5	\$228,585	JU	5811P	30.5	\$262,873	JUE	\$5,117	\$22,007	8VM
500	11700	5812P	30.5	\$253,980	JU	5812P	30.5	\$292,077	JUE	\$5,688	N/A	8VM
600	11700	5812P	30.5	\$258,488	JU	5812P	30.5	\$297,261	JUE	\$6,620	N/A	8VM
700	15000	6812PA	36	\$278,685	JU	6812PA	36	\$320,488	JUE	\$7,704	N/A	9VM
800	15000	6812PA	36	\$296,606	JU	6812PA	36	\$341,097	JUE	\$8,937	N/A	9VM
900	15000	6812PA	36	\$314,422	JU	6812PA	36	\$361,585	JUE	\$9,301	N/A	9VM
1000	15000	6812PA	36	\$330,126	JU	6812PA	36	\$379,645	JUE	\$10,417	N/A	9VM

Momentary Upthrust Capacity is 30% of Standard High Thrust Design
 • NRR = Non-Reverse Ratchet SRC= Self Release Coupling

See Page M-84 For Available And Alternate BD Dimensions



† All marks shown within this document are properties of their respective owners.

Three Phase Modifiable Motors
Vertical HOLLOSHAFT®
High Thrust - "P" Base
Totally Enclosed Fan Cooled (TEFC)
10 Pole, 720 RPM



APPLICATIONS:

For use on Turbine, Mix Flow and Propeller Pumps

FEATURES:

- * Class F Insulation, Class B Rise at Full Load (Sine Wave Power)
- * 1.00 Service Factor (Sine Wave Power)
- * Maximum 40 Deg. C. Ambient, 3,300 Feet Altitude
- * NEMA Design "B"
- * 3 Phase 60 Hz

200, 230/460, 575 Volts (&)

HP	Down Thrust (lbs)(#)	Standard Efficient			Premium Efficient			NRR List Adder	Adder C.L.1 Grp. D. Haz. Loc.	Disc. Sym
		Frame	SRC List	Type	Frame	SRC List	Type			
1.5	3400	213TP	\$3,258	TU	213TP	\$3,850	TUS	\$326	\$822	7VM
2	3400	215TP	\$3,838	TU	215TP	\$4,535	TUS	\$385	\$822	7VM
3	4500	254TP	\$5,697	TU	254TP	\$6,732	TUS	\$570	\$1,502	7VM
5	4500	256TP	\$7,040	TU	256TP	\$8,315	TUS	\$702	\$1,502	7VM
7.5	4500	284TP	\$8,103	TU	284TP	\$9,420	TUS	\$810	\$2,347	7VM
10	4500	286TP	\$8,962	TU	286TP	\$10,587	TUS	\$894	\$2,347	7VM
15	6000	324TP	\$11,408	TU	324TP	\$13,157	TUS	\$1,026	\$3,192	7VM
20	7600	364TP	\$13,371	TU	364TP	\$15,580	TUS	\$1,202	\$4,225	7VM
25	7600	365TP	\$15,401	TU	365TP	\$17,711	TUS	\$1,385	\$4,225	7VM
30	9500	404TP	\$18,427	TU	404TP	\$21,768	TUS	\$1,526	\$4,930	7VM
40	9500	405TP	\$22,204	TU	405TP	\$26,047	TUS	\$1,631	\$4,930	7VM
50	12600	444TP	\$26,796	TU	444TP	\$31,525	TUS	\$1,854	\$6,103	7VM
60	12600	447TP	\$30,911	TU	447TP	\$36,254	TUS	\$1,869	\$7,042	7VM
75	12600	447TP	\$36,784	TU	447TP	\$44,028	TUS	\$1,995	\$7,042	7VM
100	11900	449TP	\$64,068	JU	449TP	\$73,678	JUE	\$1,887	N/A	9VM
	11900	5008P	\$75,364	EU	5008P	\$86,669	EUE	\$1,887	---	9VM
125	11900	449TP	\$67,075	JU	449TP	\$77,136	JUE	\$2,014	N/A	9VM
	11900	5008P	\$81,756	EU	5008P	\$94,019	EUE	\$2,014	---	9VM
150	11900	449TP	\$89,143	JU	449TP	\$102,514	JUE	\$2,674	N/A	9VM
	11900	5008P	\$102,514	EU	5008P	\$117,892	EUE	\$2,674	---	9VM
200	13100	5807P	\$121,164	JU	5807P	\$139,338	JUE	\$3,634	\$13,469	9VM
250	13100	5809P	\$137,279	JU	5809P	\$157,871	JUE	\$4,385	\$13,469	9VM
300	13100	5809P	\$147,843	JU	5809P	\$170,019	JUE	\$5,261	\$13,469	9VM
350	13100	5811P	\$169,542	JU	5811P	\$194,974	JUE	\$5,589	\$19,484	9VM
400	13100	5811P	\$195,223	JU	5811P	\$224,507	JUE	\$5,918	\$19,484	9VM
500	12600	5812P	\$207,060	JU	5812P	\$238,119	JUE	\$6,388	N/A	9VM
600	16300	6812PA	\$233,979	JU	6812PA	\$269,076	JUE	\$7,730	N/A	9VM
700	16300	6812PA	\$264,396	JU	6812PA	\$304,055	JUE	\$8,344	N/A	9VM

Momentary Upthrust Capacity is 30% of Standard High Thrust Design

& Standard Voltages Thru 404 Frame; 405 Frame & Larger, Single Voltage 460 or 575 is standard

• NRR = Non-Reverse Ratchet SRC= Self Release Coupling

See Page M-84 For Available And Alternate BD Dimensions



Three Phase Modifiable Motors
Vertical HOLLOSHAFT®
High Thrust - "P" Base
Totally Enclosed Fan Cooled (TEFC)
10 Pole, 720 RPM



APPLICATIONS:

For use on Turbine, Mix Flow and Propeller Pumps

FEATURES:

- * Class F Insulation, Class B Rise at Full Load (Sine Wave Power)
- * 1.00 Service Factor (Sine Wave Power)
- * Maximum 40 Deg. C. Ambient, 3,300 Feet Altitude
- * NEMA Design "B"
- * 3 Phase 60 Hz

2300 Volts

HP	Down Thrust (lbs) (#)	Standard Efficient				Premium Efficient				NRR List Adder	Adder C.L.1 Grp. D. Haz. Loc.	Disc. Sym
		Frame	BD (in)	SRC List	Type	Frame	BD (in)	SRC List	Type			
150	13100	5807P	30.5	\$128,538	JU	5807P	30.5	\$147,818	JUE	\$2,390	\$13,469	9VM
200	13100	5809P	30.5	\$144,186	JU	5809P	30.5	\$165,814	JUE	\$2,721	\$19,484	9VM
250	13100	5809P	30.5	\$162,676	JU	5809P	30.5	\$187,077	JUE	\$3,852	\$19,484	9VM
300	13100	5811P	30.5	\$175,016	JU	5811P	30.5	\$201,269	JUE	\$4,385	\$22,007	9VM
350	13100	5811P	30.5	\$200,906	JU	5811P	30.5	\$231,042	JUE	\$5,117	\$22,007	9VM
400	12600	5812P	30.5	\$228,408	JU	5812P	30.5	\$262,669	JUE	\$5,688	N/A	9VM
450	12600	5812P	30.5	\$265,050	JU	5812P	30.5	\$304,808	JUE	\$6,620	N/A	9VM
500	12600	5812P	30.5	\$294,498	JU	5812P	30.5	\$338,673	JUE	\$7,613	N/A	9VM
600	12600	5812P	30.5	\$320,033	JU	5812P	30.5	\$368,038	JUE	\$8,755	N/A	9VM
700	16300	6812PA	36	\$345,039	JU	6812PA	36	\$396,795	JUE	\$10,068	N/A	9VM
800	16300	6812PA	36	\$370,365	JU	6812PA	36	\$425,920	JUE	\$11,578	N/A	9VM

4160 Volts

HP	Down Thrust (lbs) (#)	Standard Efficient				Premium Efficient				NRR List Adder	Adder C.L.1 Grp. D. Haz. Loc.	Disc. Sym
		Frame	BD (in)	SRC List	Type	Frame	BD (in)	SRC List	Type			
150	13100	5807P	30.5	\$137,109	JU	5807P	30.5	\$157,675	JUE	\$2,390	\$13,469	9VM
200	13100	5809P	30.5	\$171,582	JU	5809P	30.5	\$197,319	JUE	\$2,721	\$19,484	9VM
250	13100	5809P	30.5	\$193,584	JU	5809P	30.5	\$222,622	JUE	\$3,852	\$19,484	9VM
300	13100	5811P	30.5	\$208,270	JU	5811P	30.5	\$239,510	JUE	\$4,385	\$22,007	9VM
350	13100	5811P	30.5	\$239,078	JU	5811P	30.5	\$274,940	JUE	\$5,117	\$22,007	9VM
400	12600	5812P	30.5	\$271,805	JU	5812P	30.5	\$312,576	JUE	\$5,688	N/A	9VM
450	12600	5812P	30.5	\$315,410	JU	5812P	30.5	\$362,722	JUE	\$6,620	N/A	9VM
500	12600	5812P	30.5	\$350,452	JU	5812P	30.5	\$403,020	JUE	\$7,613	N/A	9VM
600	12600	5812P	30.5	\$380,839	JU	5812P	30.5	\$437,965	JUE	\$8,755	N/A	9VM
700	16300	6812PA	36	\$410,597	JU	6812PA	36	\$472,187	JUE	\$10,068	N/A	9VM
800	16300	6812PA	36	\$440,735	JU	6812PA	36	\$506,845	JUE	\$11,578	N/A	9VM

Momentary Upthrust Capacity is 30% of Standard High Thrust Design
 • NRR = Non-Reverse Ratchet

See Page M-84 For Available And Alternate BD Dimensions



† All marks shown within this document are properties of their respective owners.

Three Phase Modifiable Motors
Vertical Solid Shaft
High Thrust - "P" Base
Weather Protected Type I (WPI)
2 Pole, 3600 RPM



APPLICATIONS:

For use on Turbine, Mix Flow and Propeller Pumps

FEATURES:

- * Class F Insulation, Class B Rise at Full Load (Sine Wave Power)
- * 1.15 Service Factor (Sine Wave Power)
- * Maximum 40 Deg. C. Ambient, 3,300 Feet Altitude
- * NEMA Design "B"
- * 3 Phase 60 Hz

200, 230/460, 575 Volts (&)

HP	Down Thrust (lbs) (#)	Standard Efficient			Energy Efficient			Premium Efficient			NRR List Adder	Disc. Sym
		Frame	List	Type	Frame	List	Type	Frame	List	Type		
20	2600	254VP	\$3,170	AV-4	254VP	\$3,942	AVE-4	254VP	\$4,150	AVS-4	\$347	7VHTM
25	2600	256VP	\$3,405	AV-4	256VP	\$4,240	AVE-4	256VP	\$4,463	AVS-4	\$371	7VHTM
30	2600	284VPZ	\$3,660	AV-4	284VPZ	\$4,718	AVE-4	284VPZ	\$4,967	AVS-4	\$399	7VHTM
40	2600	286VPZ	\$4,440	AV-4	286VPZ	\$5,742	AVE-4	286VPZ	\$6,044	AVS-4**	\$526	7VHTM
50	4600	324VP	\$5,471	RV-4	324VP	\$6,413	RVE-4	324VP	\$6,750	RVS-4	\$535	7VHTM
60	4600	326VP	\$6,231	RV-4	326VP	\$7,318	RVE-4	326VP	\$7,703	RVS-4	\$638	7VHTM
75	4500	364VP	\$7,223	RV-4	364VP	\$8,494	RVE-4	364VP	\$8,941	RVS-4	\$793	7VHTM
100	4500	365VP	\$10,177	RV-4	365VP	\$11,969	RVE-4	365VP	\$12,599	RVS-4	\$1,075	7VHTM
125	5200	404VP	\$13,293	RV-4	404VP	\$15,073	RVE-4	404VP	\$15,866	RVS-4	\$1,347	7VHTM
150	5200	405VP	\$15,977	RV-4	405VP	\$21,011	RVE-4	405VP	\$22,117	RVS-4	\$1,347	7VHTM
200	7000	444VP	\$22,018	RV-4	444VP	\$27,473	RVE-4	444VP	\$28,919	RVS-4	N/A	7VHTM
250	7000	445VP	\$28,177	RV-4	445VP	\$32,182	RVE-4	445VP	\$33,876	RVS-4	N/A	7VHTM
300	7000	5008VP	\$45,338	RV-4	5008VP	\$53,844	RV-4	5008VP	\$56,678	RVE-4	N/A	8VM
350	7000	5008VP	\$58,979	RV-4	5008VP	\$70,037	RV-4	5008VP	\$73,723	RVE-4	N/A	8VM
400	7000	5008VP	\$70,488	RV-4	5008VP	\$83,703	RV-4	5008VP	\$88,108	RVE-4	N/A	8VM
450	7000	5008VP	\$73,458	RV-4	5008VP	\$87,235	RV-4	5008VP	\$91,826	RVE-4	N/A	8VM
500	7000	5008VP	\$76,427	RV-4	5008VP	\$90,752	RV-4	5008VP	\$95,528	RVE-4	N/A	8VM
600	7000	5012VP	\$91,711	RV-4	---	---	---	5012VP	\$114,636	RVE-4	N/A	8VM

The Open Motor Product Is Not Available Below 254 Frame, Use TEFC
 # Momentary Upthrust Capacity is 30% of Standard High Thrust Design
 & Standard Voltages Through 365 Frame; Single Voltage 400 or 575 Is Standard
 Non-reverse ratchets are not available on 2-pole, 440 frames and larger
 • NRR = Non-Reverse Ratchet
 ** Cast Iron Frame

See Page M-83 For Available And Alternate BD Dimensions
 * 60Hz 3600, 1800, 1200 & 900 RPM motors comply with U.S. D.O.E.'s Efficiency regulation 10 CFR Section 431 Subpart B – electric motors (See Page M-80 - M-81 for Nominal Efficiency Table)



Three Phase Modifiable Motors
Vertical Solid Shaft
High Thrust - "P" Base
Weather Protected Type I (WPI)
2 Pole, 3600 RPM



APPLICATIONS:

For use on Turbine, Mix Flow and Propeller Pumps

FEATURES:

- * Class F Insulation, Class B Rise at Full Load (Sine Wave Power)
- * 1.15 Service Factor (Sine Wave Power)
- * Maximum 40 Deg. C. Ambient, 3,300 Feet Altitude
- * NEMA Design "B"
- * 3 Phase 60 Hz

2300 Volt

HP	Down Thrust (lbs) (#)	Standard Efficient				Premium Efficient				NRR List Adder	Disc. Sym
		Frame	BD (in)	List	Type	Frame	BD(in)	List	Type		
150	7000	5008VP	24.5	\$42,690	RV-4	5008VP	24.5	\$49,094	RVE-4	N/A	8VM
200	7000	5008VP	24.5	\$44,033	RV-4	5008VP	24.5	\$50,634	RVE-4	N/A	8VM
250	7000	5008VP	24.5	\$52,573	RV-4	5008VP	24.5	\$60,460	RVE-4	N/A	8VM
300	7000	5008VP	24.5	\$60,225	RV-4	5008VP	24.5	\$69,261	RVE-4	N/A	8VM
350	7000	5008VP	24.5	\$67,883	RV-4	5008VP	24.5	\$78,063	RVE-4	N/A	8VM
400	7000	5008VP	24.5	\$75,200	RV-4	5008VP	24.5	\$86,479	RVE-4	N/A	8VM
450	7000	5008VP	24.5	\$83,188	RV-4	5008VP	24.5	\$95,667	RVE-4	N/A	8VM
500	7000	5012VP	24.5	\$90,840	RV-4	5012VP	24.5	\$104,467	RVE-4	N/A	8VM
600	7000	5012VP	24.5	\$112,660	RV-4	5012VP	24.5	\$129,556	RVE-4	N/A	8VM
700	7000	5012VP	24.5	\$127,277	RV-4	5012VP	24.5	\$146,369	RVE-4	N/A	8VM
800	7000	5012VP	24.5	\$141,892	RV-4	5012VP	24.5	\$163,178	RVE-4	N/A	8VM

4160 Volt

HP	Down Thrust (lbs) (#)	Standard Efficient				Premium Efficient				NRR List Adder	Disc. Sym
		Frame	BD (in)	List	Type	Frame	BD(in)	List	Type		
150	7000	5008VP	24.5	\$49,094	RV-4	5008VP	24.5	\$56,458	RVE-4	N/A	8VM
200	7000	5008VP	24.5	\$50,634	RV-4	5008VP	24.5	\$58,228	RVE-4	N/A	8VM
250	7000	5008VP	24.5	\$60,467	RV-4	5008VP	24.5	\$69,538	RVE-4	N/A	8VM
300	7000	5008VP	24.5	\$69,263	RV-4	5008VP	24.5	\$79,655	RVE-4	N/A	8VM
350	7000	5008VP	24.5	\$78,063	RV-4	5008VP	24.5	\$89,775	RVE-4	N/A	8VM
400	7000	5008VP	24.5	\$86,479	RV-4	5012VP	24.5	\$99,451	RVE-4	N/A	8VM
450	7000	5008VP	24.5	\$95,667	RV-4	5012VP	24.5	\$110,014	RVE-4	N/A	8VM
500	7000	5012VP	24.5	\$104,467	RV-4	5012VP	24.5	\$120,136	RVE-4	N/A	8VM
600	7000	5012VP	24.5	\$128,089	RV-4	5012VP	24.5	\$147,303	RVE-4	N/A	8VM
700	7000	5012VP	24.5	\$143,188	RV-4	5012VP	24.5	\$164,667	RVE-4	N/A	8VM
800	7000	5012VP	24.5	\$159,631	RV-4	5012VP	24.5	\$183,575	RVE-4	N/A	8VM

Momentary Upthrust Capacity is 30% of Standard High Thrust Design
 • NRR = Non-Reverse Ratchet - Not available on these ratings

See Page M-83 For Available And Alternate BD Dimensions



† All marks shown within this document are properties of their respective owners.

Three Phase Modifiable Motors
Vertical Solid Shaft
High Thrust - "P" Base
Weather Protected Type I (WPI)
4 Pole, 1800 RPM



APPLICATIONS:

For use on Turbine, Mix Flow and Propeller Pumps

FEATURES:

- * Class F Insulation, Class B Rise at Full Load (Sine Wave Power)
- * 1.15 Service Factor (Sine Wave Power)
- * Maximum 40 Deg. C. Ambient, 3,300 Feet Altitude
- * NEMA Design "B"
- * 3 Phase 60 Hz

200, 230/460, 575 Volts (&)

HP	Down Thrust (lbs) (#)	Standard Efficient			Energy Efficient			Premium Efficient			NRR List Adder	Disc. Sym
		Frame	List	Type	Frame	List	Type	Frame	List	Type		
15	3300	254VP	\$3,018	AV-4	254VP	\$3,661	AVE-4	254VP	\$3,854	AVS-4	\$329	7VHTM
20	3300	256VP	\$3,350	AV-4	256VP	\$4,013	AVE-4	256VP	\$4,224	AVS-4	\$376	7VHTM
25	3300	284VPZ	\$3,832	AV-4	284VPZ	\$4,567	AVE-4	284VPZ	\$4,807	AVS-4	\$418	7VHTM
30	3300	286VPZ	\$4,173	AV-4	286VPZ	\$4,975	AVE-4	286VPZ	\$5,236	AVS-4	\$465	7VHTM
40	5700	324VP	\$4,681	RV-4	324VP	\$6,357	RVE-4	324VP	\$6,692	RVS-4	\$484	7VHTM
50	5700	326VP	\$5,488	RV-4	326VP	\$7,083	RVE-4	326VP	\$7,456	RVS-4	\$577	7VHTM
60	5700	364VP	\$6,456	RV-4	364VP	\$8,448	RVE-4	364VP	\$8,893	RVS-4	\$662	7VHTM
75	5700	365VP	\$7,696	RV-4	365VP	\$9,609	RVE-4	365VP	\$10,115	RVS-4	\$808	7VHTM
100	6700	404VP	\$9,863	RV-4	404VP	\$11,461	RVE-4	404VP	\$12,064	RVS-4	\$1,019	7VHTM
125	6700	405VP	\$12,256	RV-4	405VP	\$14,268	RVE-4	405VP	\$15,019	RVS-4	\$1,235	7VHTM
150	9800	H444VP	\$16,304	RV-4	H444VP	\$18,590	RVE-4	H444VP	\$19,568	RVS-4	\$1,300	7VHTM
200	9800	H445VP	\$20,826	RV-4	H445VP	\$23,828	RVE-4	H445VP	\$25,082	RVS-4	\$1,347	7VHTM
250	9800	H445VP	\$26,590	RV-4	H445VP	\$30,312	RVE-4	H445VP	\$31,907	RVS-4	\$1,347	7VHTM
300	9800	447VP@	\$30,578	RV-4	447VP@	\$34,859	RVE-4	447VP@	\$36,693	RVS-4	\$1,559	7VHTM
350	9800	447VP@	\$34,400	RV-4	447VP@	\$39,216	RVE-4	447VP@	\$41,280	RVS-4	\$1,559	7VHTM
400	9500	449VP@	\$49,305	RV-4	449VP@	\$58,549	RV-4	449VP@	\$61,631	RVS-4	\$1,570	8VM
450	9500	449VP@	\$55,458	RV-4	449VP@	\$65,856	RV-4	449VP@	\$69,322	RVS-4	\$1,596	8VM
500	9500	449VP@	\$64,522	RV-4	449VP@	\$70,490	RV-4	449VP@	\$74,200	RVE-4	\$1,761	8VM
600	9500	5008VP	\$73,063	RV-4	---	---	---	5008VP	\$91,329	RVE-4	\$1,908	8VM
700	10300	5012VP	\$85,242	RV-4	---	---	---	5012VP	\$106,549	RVE-4	\$2,214	8VM
800	10300	5012VP	\$97,418	RV-4	---	---	---	5012VP	\$121,772	RVE-4	\$2,531	8VM

The Open Motor Product Is Not Available Below 254 Frame, use TEFC
 # Momentary Upthrust Capacity is 30% of Standard High Thrust Design
 & Standard Voltages Thru 404 Frame; 405 Frame & Larger, Single Voltage 460 or 575 is standard
 @Contact your Nidec Motor Corporation Technical Representative for WPII frame size confirmation prior to quoting.
 + 10,300 Lbs. Downthrust For 5012 Frame
 • NRR = Non-Reverse Ratchet

See Page M-83 For Available And Alternate BD Dimensions
 * 60Hz 3600, 1800, 1200 & 900 RPM motors comply with U.S. D.O.E.'s Efficiency regulation 10 CFR Section 431 Subpart B – electric motors (See Page M-80 - M-81 for Nominal Efficiency Table)



Three Phase Modifiable Motors
Vertical Solid Shaft
High Thrust - "P" Base
Weather Protected Type I (WPI)
4 Pole, 1800 RPM



APPLICATIONS:

For use on Turbine, Mix Flow and Propeller Pumps

FEATURES:

- * Class F Insulation, Class B Rise at Full Load (Sine Wave Power)
- * 1.15 Service Factor (Sine Wave Power)
- * Maximum 40 Deg. C. Ambient, 3,300 Feet Altitude
- * NEMA Design "B"
- * 3 Phase 60 Hz

2300 Volt

HP	Down Thrust (lbs) (#)	Standard Efficient				Premium Efficient				NRR List Adder	Disc. Sym
		Frame	BD(in)	List	Type	Frame	BD(in)	List	Type		
150	9800	447VP@	20	\$30,833	RV-4	447VP@	20	\$35,458	RVS-4	\$1,761	8VM
200	9800	447VP@	20	\$34,096	RV-4	447VP@	20	\$39,211	RVS-4	\$1,761	8VM
250	9800	447VP@	20	\$39,190	RV-4	449VP@	24.5	\$45,068	RVS-4	\$1,843	8VM
300	9500	449VP@	24.5	\$44,085	RV-4	449VP@	24.5	\$50,695	RVS-4	\$1,873	8VM
350	9500	5008VP	24.5	\$50,007	RV-4	5008VP	24.5	\$57,507	RVE-4	\$1,873	8VM
400	9500	5008VP	24.5	\$52,836	RV-4	5008VP	24.5	\$60,758	RVE-4	\$1,960	8VM
450	9500	5008VP	24.5	\$58,650	RV-4	5008VP	24.5	\$67,448	RVE-4	\$1,960	8VM
500	9500	5008VP	24.5	\$67,354	RV-4	5012VP+	24.5	\$77,455	RVE-4	\$1,995	8VM
600	10300	5012VP	24.5	\$81,432	RV-4	5012VP	24.5	\$93,646	RVE-4	\$2,183	8VM
700	10300	5012VP	24.5	\$92,535	RV-4	5012VP	24.5	\$106,415	RVE-4	\$2,425	8VM
800	10300	5012VP	24.5	\$104,061	RV-4	5012VP	24.5	\$119,669	RVE-4	\$2,425	8VM
900	10300	5012VP	24.5	\$117,068	RV-4	5012VP	24.5	\$134,627	RVE-4	\$2,484	8VM
1000	10300	5012VP	24.5	\$129,944	RV-4	5012VP	24.5	\$149,434	RVE-4	\$2,484	8VM
1250	11900	5813VP	30.5	\$162,430	RV-4	5813VP	30.5	\$186,793	RVE-4	\$3,312	8VM
1500	11900	5813VP	30.5	\$186,545	RV-4	5813VP	30.5	\$214,526	RVE-4	\$3,930	8VM
1750	11900	5813VP	30.5	\$217,636	RV-4	5813VP	30.5	\$250,279	RVE-4	\$5,441	8VM
2000	10300	6810VP	30.5	\$233,087	RV-4	6810VP	30.5	\$268,049	RVE-4	\$5,977	9VM
2250	10300	6810VP	30.5	\$240,293	RV-4	6810VP	30.5	\$276,336	RVE-4	\$6,165	9VM
2500	10300	6811VP	30.5	\$247,725	RV-4	6811VP	30.5	\$284,883	RVE-4	\$6,352	9VM
3000	10300	6813P	30.5	\$358,305	RV-4	6813P	30.5	\$412,052	RVE-4	\$10,289	9VM
3500	10300	6813P	30.5	\$395,812	RV-4	6813P	30.5	\$455,185	RVE-4	\$11,369	9VM
4000*	10300	6813P	30.5	\$413,732	RV-4	6813P	30.5	\$475,793	RVE-4	\$11,880	9VM
4500*	8600	9608PH	42	\$438,829	RV-4	9608PH	42	\$504,655	RVE-4	\$12,603	9VM
5000*	8600	9608PH	42	\$462,582	RV-4	9608PH	42	\$531,969	RVE-4	\$12,603	9VM

Momentary Upthrust Capacity is 30% of Standard High Thrust Design
+ 10,300 Lbs. Downthrust for 5012 Frame
@Contact your Nidec Motor Corporation Technical Representative for WPII frame size confirmation prior to quoting.
*Maximum Full Load Test Capacity is 3500 HP
• NRR = Non-Reverse Ratchet

See Page M-83 For Available And Alternate BD Dimensions



Three Phase Modifiable Motors
Vertical Solid Shaft
High Thrust - "P" Base
Weather Protected Type I (WPI)
4 Pole, 1800 RPM



APPLICATIONS:

For use on Turbine, Mix Flow and Propeller Pumps

FEATURES:

- * Class F Insulation, Class B Rise at Full Load (Sine Wave Power)
- * 1.15 Service Factor (Sine Wave Power)
- * Maximum 40 Deg. C. Ambient, 3,300 Feet Altitude
- * NEMA Design "B"
- * 3 Phase 60 Hz

4000 Volt

HP	Down Thrust (lbs)(#)	Standard Efficient				Premium Efficient				NRR List Adder	Disc. Sym
		Frame	BD	List	Type	Frame	BD	List	Type		
250	9500	449VP@	24.5	\$44,599	RV-4	449VP@	24.5	\$51,289	RVS-4	\$1,843	8VM
300	9500	449VP@	24.5	\$50,167	RV-4	449VP@	24.5	\$57,695	RVS-4	\$1,873	8VM
350	9500	5008VP	24.5	\$56,908	RV-4	5008VP	24.5	\$65,444	RVE-4	\$1,873	8VM
400	9500	5008VP	24.5	\$60,512	RV-4	5008VP	24.5	\$69,587	RVE-4	\$1,960	8VM
450	9500	5008VP	24.5	\$67,171	RV-4	5008VP	24.5	\$77,249	RVE-4	\$1,960	8VM
500	9500	5008VP	24.5	\$77,455	RV-4	5012VP+	24.5	\$89,075	RVE-4	\$1,995	8VM
600	10300	5012VP	24.5	\$91,610	RV-4	5012VP	24.5	\$105,352	RVE-4	\$2,183	8VM
700	10300	5012VP	24.5	\$104,531	RV-4	5012VP	24.5	\$120,211	RVE-4	\$2,425	8VM
800	10300	5012VP	24.5	\$117,549	RV-4	5012VP	24.5	\$135,183	RVE-4	\$2,425	8VM
900	10300	5012VP	24.5	\$131,962	RV-4	5012VP	24.5	\$151,758	RVE-4	\$2,484	8VM
1000	10300	5012VP	24.5	\$146,122	RV-4	5012VP	24.5	\$168,040	RVE-4	\$2,484	8VM
1250	11900	5813VP	30.5	\$179,657	RV-4	5813VP	30.5	\$206,606	RVE-4	\$3,312	8VM
1500	11900	5813VP	30.5	\$205,237	RV-4	5813VP	30.5	\$236,023	RVE-4	\$3,930	8VM
1750	11900	5813VP	30.5	\$243,751	RV-4	5813VP	30.5	\$280,315	RVE-4	\$5,441	8VM
2000	10300	6810VP	30.5	\$261,059	RV-4	6810VP	30.5	\$300,218	RVE-4	\$5,977	9VM
2250	10300	6810VP	30.5	\$269,129	RV-4	6810VP	30.5	\$309,498	RVE-4	\$5,977	9VM
2500	10300	6811VP	30.5	\$277,453	RV-4	6811VP	30.5	\$319,070	RVE-4	\$6,352	9VM
3000	10300	6813P	30.5	\$401,300	RV-4	6813P	30.5	\$461,493	RVE-4	\$10,289	9VM
3500	10300	6813P	30.5	\$443,310	RV-4	6813P	30.5	\$509,808	RVE-4	\$11,369	9VM
4000*	10300	6813P	30.5	\$463,380	RV-4	6813P	30.5	\$532,887	RVE-4	\$11,880	9VM
4500*	8600	9608PH	42	\$491,491	RV-4	9608PH	42	\$565,214	RVE-4	\$12,603	9VM
5000*	8600	9608PH	42	\$518,089	RV-4	9608PH	42	\$595,805	RVE-4	\$13,284	9VM

Momentary Upthrust Capacity is 30% of Standard High Thrust Design

+ 10,300 Lbs. Downthrust for 5012 Frame

*Maximum Full Load Test Capacity is 3500 HP

• NRR = Non-Reverse Ratchet

@Contact your Nidec Motor Corporation Technical Representative for WPII frame size confirmation prior to quoting.

See Page M-83 For Available And Alternate BD Dimensions



Three Phase Modifiable Motors
Vertical Solid Shaft
High Thrust - "P" Base
Weather Protected Type I (WPI)
6 Pole, 1200 RPM



APPLICATIONS:

For use on Turbine, Mix Flow and Propeller Pumps

FEATURES:

- * Class F Insulation, 60 Degrees C Rise At Full Load (Sine Wave Power)
- * 1.15 Service Factor (Sine Wave Power)
- * Maximum 40 Deg. C. Ambient, 3,300 Feet Altitude
- * NEMA Design "B"
- * 3 Phase 60 Hz

200, 230/460, 575 Volts (&)

HP	Down Thrust (lbs)(#)	Standard Efficient			Energy Efficient			Premium Efficient			NRR List Adder	Disc. Sym
		Frame	List	Type	Frame	List	Type	Frame	List	Type		
7.5	3800	254VP	\$3,239	AV-4	254VP	\$3,887	AVE-4	254VP	\$4,092	AVS-4	\$376	7VHTM
10	3800	256VP	\$3,692	AV-4	256VP	\$4,429	AVE-4	256VP	\$4,662	AVS-4	\$385	7VHTM
15	3800	284VPZ	\$4,398	AV-4	284VPZ	\$5,268	AVE-4	284VPZ	\$5,545	AVS-4	\$411	7VHTM
20	3800	286VPZ	\$5,140	AV-4	286VPZ	\$6,171	AVE-4	286VPZ	\$6,496	AVS-4	\$469	7VHTM
25	6700	324VP	\$6,100	RV-4	324VP	\$7,142	RVE-4	324VP	\$7,518	RVS-4	\$540	7VHTM
30	6700	326VP	\$6,786	RV-4	326VP	\$7,958	RVE-4	326VP	\$8,376	RVS-4	\$620	7VHTM
40	6700	364VP	\$8,981	RV-4	364VP	\$10,483	RVE-4	364VP	\$11,035	RVS-4	\$756	7VHTM
50	6700	365VP	\$10,194	RV-4	365VP	\$11,923	RVE-4	365VP	\$12,551	RVS-4	\$869	7VHTM
60	7800	404VP	\$12,189	RV-4	404VP	\$14,070	RVE-4	404VP	\$14,810	RVS-4	\$1,019	7VHTM
75	7800	405VP	\$13,794	RV-4	405VP	\$15,955	RVE-4	405VP	\$16,795	RVS-4	\$1,197	7VHTM
100	11250	H444VP	\$18,001	RV-4	H444VP	\$20,469	RVE-4	H444VP	\$21,546	RVS-4	\$1,549	7VHTM
125	11250	H445VP	\$20,779	RV-4	H445VP	\$23,685	RVE-4	H445VP	\$24,931	RVS-4	\$1,549	7VHTM
150	11250	H445VP	\$24,123	RV-4	H445VP	\$27,754	RVE-4	H445VP	\$29,004	RVS-4	\$1,878	7VHTM
200	11250	447VP@	\$30,154	RV-4	447VP@	\$34,443	RV-4	447VP@	\$36,255	RVS-4	\$1,756	7VHTM
250	11250	447VP@	\$36,938	RV-4	447VP@	\$42,191	RV-4	447VP@	\$44,412	RVS-4	\$1,756	7VHTM
300	11000	449VP@	\$48,803	RV-4	449VP@	\$58,378	RV-4	449VP@	\$61,451	RVS-4	\$1,770	8VM
350	11000	5008VP	\$56,568	RV-4	5008VP	\$67,606	RV-4	5008VP	\$71,164	RVE-4	\$1,784	8VM
400	11000	5008VP	\$64,965	RV-4	5012VP+	\$77,606	RV-4	5012VP+	\$81,690	RVE-4	\$1,808	8VM
450	11900	5012VP	\$71,937	RV-4	5012VP	\$86,000	RV-4	5012VP	\$90,526	RVE-4	\$2,066	8VM
500	11900	5012VP	\$79,225	RV-4	5012VP	\$92,839	RV-4	5012VP	\$97,725	RVE-4	\$2,272	8VM
600	11900	5012VP	\$95,061	RV-4	---	---	---	5012VP	\$118,817	RVE-4	\$2,448	8VM
700	11900	5012VP	\$110,894	RV-4	---	---	---	5012VP	\$138,617	RVE-4	\$2,854	8VM
800	13700	5813VP	\$126,737	RV-4	---	---	---	5813VP	\$158,423	RVE-4	\$3,258	8VM

The Open Motor Product Is Not Available Below 254 Frame, Use TEFC
 # Momentary Upthrust Capacity is 30% of Standard High Thrust Design
 & Standard Voltages Thru 405 Frame; 444 Frame & Larger, Single Voltage 460 or 575 is Standard
 @Contact your Nidec Motor Corporation Technical Representative for WPII frame size confirmation prior to quoting.
 + 11,900 Lbs. Downthrust
 • NRR = Non-Reverse Ratchet SRC= Self Release Coupling

See Page M-83 For Available And Alternate BD Dimensions

* 60Hz 3600, 1800, 1200 & 900 RPM motors comply with U.S. D.O.E.'s Efficiency regulation 10 CFR Section 431 Subpart B – electric motors (See Page M-80 - M-81 for Nominal Efficiency Table)



Three Phase Modifiable Motors
Vertical Solid Shaft
High Thrust - "P" Base
Weather Protected Type I (WPI)
6 Pole, 1200 RPM



APPLICATIONS:

For use on Turbine, Mix Flow and Propeller Pumps

FEATURES:

- * Class F Insulation, Class B Rise at Full Load (Sine Wave Power)
- * 1.15 Service Factor (Sine Wave Power)
- * Maximum 40 Deg. C. Ambient, 3,300 Feet Altitude
- * NEMA Design "B"
- * 3 Phase 60 Hz

2300 Volt

HP	Down Thrust (lbs) (#)	Standard Efficient				Premium Efficient				NRR List Adder	Disc. Sym
		Frame	BD (in)	List	Type	Frame	BD (in)	List	Type		
150	11000	449VP@	24.5	\$37,101	RV-4	449VP@	24.5	\$42,667	RVS-4	\$1,761	8VM
200	11000	449VP@	24.5	\$43,418	RV-4	449VP@	24.5	\$49,932	RVS-4	\$1,761	8VM
250	11000	449VP@	24.5	\$52,049	RV-4	449VP@	24.5	\$59,857	RVS-4	\$1,831	8VM
300	11000	5008VP	24.5	\$56,960	RV-4	5008VP	24.5	\$65,505	RVE-4	\$1,890	8VM
350	11000	5008VP	24.5	\$67,366	RV-4	5008VP	24.5	\$77,472	RVE-4	\$2,120	8VM
400	11000	5008VP	24.5	\$74,495	RV-4	5012VP+	24.5	\$85,669	RVE-4	\$2,214	8VM
450	11000	5008VP	24.5	\$81,638	RV-4	5012VP+	24.5	\$93,883	RVE-4	\$2,343	8VM
500	11900	5012VP	24.5	\$88,075	RV-4	5012VP	24.5	\$101,286	RVE-4	\$2,531	8VM
600	11900	5012VP	24.5	\$104,176	RV-4	5012VP	24.5	\$119,800	RVE-4	\$2,608	8VM
700	11900	5012VP	24.5	\$113,498	RV-4	5012VP	24.5	\$130,523	RVE-4	\$4,991	8VM
800	13700	5813VP	30.5	\$124,162	RV-4	5813VP	30.5	\$142,784	RVE-4	\$5,502	8VM
900	13700	5813VP	30.5	\$140,336	RV-4	5813VP	30.5	\$161,385	RVE-4	\$5,777	8VM
1000	13700	5813VP	30.5	\$152,674	RV-4	5813VP	30.5	\$175,575	RVE-4	\$5,981	8VM
1250	13700	5813VP	30.5	\$175,397	RV-4	5813VP	30.5	\$201,704	RVE-4	\$6,099	8VM
1500	11900	6810VP	30.5	\$199,866	RV-4	6810VP	30.5	\$229,845	RVE-4	\$6,176	8VM
1750	11900	6810VP	30.5	\$225,735	RV-4	6810VP	30.5	\$259,596	RVE-4	\$6,305	9VM
2000	11900	6811VP	30.5	\$257,981	RV-4	6811VP	30.5	\$296,678	RVE-4	\$6,599	9VM
2250	11900	6813P	30.5	\$290,230	RV-4	6813P	30.5	\$333,765	RVE-4	\$7,420	9VM
2500	11900	6813P	30.5	\$322,477	RV-4	6813P	30.5	\$370,847	RVE-4	\$8,249	9VM
3000	10400	9606PH	42	\$361,817	RV-4	9606PH	42	\$416,089	RVE-4	\$9,995	9VM
3500	10400	9607PH	42	\$409,937	RV-4	9607PH	42	\$471,427	RVE-4	\$11,324	9VM
4000*	10400	9608PH	42	\$468,962	RV-4	9608PH	42	\$539,305	RVE-4	\$12,953	9VM

Momentary Upthrust Capacity is 30% of Standard High Thrust Design
+11,900 Lbs. Downthrust for 5012 Frame
* Maximum Full Load Test Capacity is 3500 HP
• NRR = Non-Reverse Ratchet
@Contact your Nidec Motor Corporation Technical Representative for WPII frame size confirmation prior to quoting.

See Page M-83 For Available And Alternate BD Dimensions



Three Phase Modifiable Motors
Vertical Solid Shaft
High Thrust - "P" Base
Weather Protected Type I (WPI)
6 Pole, 1200 RPM



APPLICATIONS:

For use on Turbine, Mix Flow and Propeller Pumps

FEATURES:

- * Class F Insulation, Class B Rise at Full Load (Sine Wave Power)
- * 1.15 Service Factor (Sine Wave Power)
- * Maximum 40 Deg. C. Ambient, 3,300 Feet Altitude
- * NEMA Design "B"
- * 3 Phase 60 Hz

4000 Volt

HP	Down Thrust (lbs) (#)	Standard Efficient				Premium Efficient				NRR List Adder	Disc. Sym
		Frame	BD (in)	List	Type	Frame	BD (in)	List	Type		
150	11000	449VP@	24.5	\$47,441	RV-4	449VP@	24.5	\$54,556	RVS-4	\$1,761	8VM
200	11000	5008VP	24.5	\$55,394	RV-4	5008VP	24.5	\$63,704	RVE-4	\$1,831	8VM
250	11000	5008VP	24.5	\$59,272	RV-4	5008VP	24.5	\$68,164	RVE-4	\$1,831	8VM
300	11000	5008VP	24.5	\$65,284	RV-4	5008VP	24.5	\$75,077	RVE-4	\$1,890	8VM
350	11000	5008VP	24.5	\$76,716	RV-4	5008VP	24.5	\$88,225	RVE-4	\$2,120	8VM
400	11000	5008VP	24.5	\$84,838	RV-4	5012VP+	24.5	\$97,566	RVE-4	\$2,214	8VM
450	11000	5008VP	24.5	\$92,054	RV-4	5012VP+	24.5	\$105,864	RVE-4	\$2,343	8VM
500	11900	5012VP	24.5	\$99,063	RV-4	5012VP	24.5	\$113,923	RVE-4	\$2,531	8VM
600	11900	5012VP	24.5	\$116,228	RV-4	5012VP	24.5	\$133,662	RVE-4	\$2,608	8VM
700	11900	5012VP	24.5	\$126,634	RV-4	5012VP	24.5	\$145,631	RVE-4	\$4,991	8VM
800	13700	5813VP	30.5	\$138,533	RV-4	5813VP	30.5	\$159,315	RVE-4	\$5,502	8VM
900	13700	5813VP	30.5	\$151,561	RV-4	5813VP	30.5	\$174,296	RVE-4	\$5,777	8VM
1000	13700	5813VP	30.5	\$164,890	RV-4	5813VP	30.5	\$189,622	RVE-4	\$5,981	8VM
1250	13700	5813VP	30.5	\$189,427	RV-4	5813VP	30.5	\$217,843	RVE-4	\$6,099	8VM
1500	11900	6810VP	30.5	\$215,854	RV-4	6810VP	30.5	\$248,230	RVE-4	\$6,176	8VM
1750	11900	6810VP	30.5	\$243,791	RV-4	6810VP	30.5	\$280,362	RVE-4	\$6,305	9VM
2000	11900	6811VP	30.5	\$278,622	RV-4	6811VP	30.5	\$320,413	RVE-4	\$6,599	9VM
2250	11900	6813P	30.5	\$313,448	RV-4	6813P	30.5	\$360,465	RVE-4	\$7,420	9VM
2500	11900	6813P	30.5	\$348,275	RV-4	6813P	30.5	\$400,516	RVE-4	\$8,249	9VM
3000	10400	9606PH	42	\$390,761	RV-4	9606PH	42	\$449,376	RVE-4	\$9,995	9VM
3500	10400	9607PH	42	\$442,725	RV-4	9607PH	42	\$509,134	RVE-4	\$11,324	9VM
4000	10400	9608PH	42	\$506,474	RV-4	9608PH	42	\$582,444	RVE-4	\$12,953	9VM

Momentary Upthrust Capacity is 30% of Standard High Thrust Design

+11,900 Lbs. Downthrust for 5012 Frame

• NRR = Non-Reverse Ratchet

@Contact your Nidec Motor Corporation Technical Representative for WPII frame size confirmation prior to quoting.

See Page M-83 For Available And Alternate BD Dimensions



Three Phase Modifiable Motors
Vertical Solid Shaft
High Thrust - "P" Base
Weather Protected Type I (WPI)
8 Pole, 900 RPM



APPLICATIONS:

For use on Turbine, Mix Flow and Propeller Pumps

FEATURES:

- * Class F Insulation, Class B Rise at Full Load (Sine Wave Power)
- * 1.15 Service Factor (Sine Wave Power)
- * Maximum 40 Deg. C. Ambient, 3,300 Feet Altitude
- * NEMA Design "B"
- * 3 Phase 60 Hz

200, 230/460 575 Volts (&)

HP	Down Thrust (lbs) (#)	Standard Efficient			Energy Efficient			Premium Efficient			NRR List Adder	Disc. Sym
		Frame	List	Type	Frame	List	Type	Frame	List	Type		
5	4200	254VP	\$3,372	AV-4	254VP	\$4,038	AVE-4	254VP	\$4,250	AVS-4	\$333	7VHTM
7.5	4200	256VP	\$3,771	AV-4	256VP	\$4,523	AVE-4	256VP	\$4,761	AVS-4	\$385	7VHTM
10	4200	284VPZ	\$4,306	AV-4	284VPZ	\$5,156	AVE-4	284VPZ	\$5,427	AVS-4	\$427	7VHTM
15	4200	286VPZ	\$5,220	AV-4	286VPZ	\$6,270	AVE-4	286VPZ	\$6,600	AVS-4	\$540	7VHTM
20	7400	324VP	\$6,271	RV-4	324VP	\$7,345	RVE-4	324VP	\$7,732	RVS-4	\$563	7VHTM
25	7400	326VP	\$7,034	RV-4	326VP	\$8,250	RVE-4	326VP	\$8,685	RVS-4	\$643	7VHTM
30	7400	364VP	\$8,706	RV-4	364VP	\$10,154	RVE-4	364VP	\$10,689	RVS-4	\$728	7VHTM
40	7400	365VP	\$10,039	RV-4	365VP	\$11,739	RVE-4	365VP	\$12,357	RVS-4	\$873	7VHTM
50	8600	404VP	\$11,994	RV-4	404VP	\$13,839	RVE-4	404VP	\$14,568	RVS-4	\$995	7VHTM
60	8600	405VP	\$13,541	RV-4	405VP	\$15,447	RVE-4	405VP	\$16,260	RVS-4	\$1,150	7VHTM
75	12500	H444VP	\$15,304	RV-4	H444VP	\$17,457	RVE-4	H444VP	\$18,376	RVS-4	\$1,164	7VHTM
100	12500	H445VP	\$19,612	RV-4	H445VP	\$22,429	RVE-4	H445VP	\$23,609	RVS-4	\$1,554	7VHTM
125	12500	447VP@	\$27,457	RV-4	447VP@	\$31,400	RV-4	447VP@	\$33,053	RVS-4	\$1,937	7VHTM
150	12500	447VP@	\$30,889	RV-4	447VP@	\$35,325	RV-4	447VP@	\$37,185	RVS-4	\$1,937	7VHTM
200	12000	449VP@	\$41,761	RV-4	449VP@	\$45,622	RV-4	449VP@	\$48,023	RVS-4	\$1,981	8VM
250	12000	5008VP	\$50,641	RV-4	5012VP+	\$55,323	RV-4	5012VP+	\$58,235	RVE-4	\$2,011	8VM
300	13200	5012VP	\$59,894	RV-4	5012VP	\$65,436	RV-4	5012VP	\$68,880	RVE-4	\$2,054	8VM
350	13200	5012VP	\$69,589	RV-4	5012VP	\$76,025	RV-4	5012VP	\$80,026	RVE-4	\$2,230	8VM
400	13200	5012VP	\$78,908	RV-4	5012VP	\$86,209	RV-4	5012VP	\$90,746	RVE-4	\$2,265	8VM
450	13200	5012VP	\$88,099	RV-4	5012VP	\$96,249	RV-4	5012VP	\$101,315	RVE-4	\$2,531	8VM
500	13200	5012VP	\$97,439	RV-4	5012VP	\$106,451	RV-4	5012VP	\$112,054	RVE-4	\$3,516	8VM
600	15000	5813VP	\$128,305	RV-4	---	---	---	5813VP	\$145,824	RVE-4	\$4,608	8VM
700	15000	5813VP	\$143,286	RV-4	---	---	---	5813VP	\$163,746	RVE-4	\$5,143	8VM
800	15000	5813VP	\$163,758	RV-4	---	---	---	5813VP	\$187,171	RVE-4	\$5,878	8VM

The Open Motor Product Is Not Available Below 254 Frame. Use TEFC
 # Momentary Upthrust Capacity is 30% of Standard High Thrust Design
 & Standard Voltages Thru 405 Frame; 444 Frame & Larger, Single Voltage 460 or 575 is standard
 @Contact your Nidec Motor Corporation Technical Representative for WPII frame size confirmation prior to quoting.
 + 13,200 Lbs Down Thrust
 • NRR = Non-Reverse Ratchet SRC= Self Release Coupling

See Page M-83 For Available And Alternate BD Dimensions
 * 60Hz 3600, 1800, 1200 & 900 RPM motors comply with U.S. D.O.E.'s Efficiency regulation 10 CFR Section 431 Subpart B – electric motors (See Page M-80 - M-81 for Nominal Efficiency Table)



Three Phase Modifiable Motors
Vertical Solid Shaft
High Thrust - "P" Base
Weather Protected Type I (WPI)
8 Pole, 900 RPM



APPLICATIONS:

For use on Turbine, Mix Flow and Propeller Pumps

FEATURES:

- * Class F Insulation, Class B Rise at Full Load (Sine Wave Power)
- * 1.15 Service Factor (Sine Wave Power)
- * Maximum 40 Deg. C. Ambient, 3,300 Feet Altitude
- * NEMA Design "B"
- * 3 Phase 60 Hz

2300 Volt

HP	Down Thrust (lbs) (#)	Standard Efficient				Premium Efficient				NRR List Adder	Disc. Sym
		Frame	BD (in)	List	Type	Frame	BD (in)	List	Type		
150	12000	449VP@	24.5	\$43,617	RV-4	449VP@	24.5	\$50,162	RVS-4	\$1,995	8VM
200	12000	5008VP	24.5	\$54,059	RV-4	5008VP	24.5	\$62,167	RVE-4	\$2,009	8VM
250	12000	5008VP	24.5	\$64,495	RV-4	5012VP+	24.5	\$74,169	RVE-4	\$2,049	8VM
300	13200	5012VP	24.5	\$73,474	RV-4	5012VP	24.5	\$84,495	RVE-4	\$2,167	8VM
350	13200	5012VP	24.5	\$82,406	RV-4	5012VP	24.5	\$94,768	RVE-4	\$2,366	8VM
400	13200	5012VP	24.5	\$91,087	RV-4	5012VP	24.5	\$104,749	RVE-4	\$2,617	8VM
450	13200	5012VP	24.5	\$98,998	RV-4	5012VP	24.5	\$113,847	RVE-4	\$2,840	8VM
500	13200	5012VP	24.5	\$115,620	RV-4	5012VP	24.5	\$132,960	RVE-4	\$3,516	8VM
600	15000	5813VP	30.5	\$127,920	RV-4	5813VP	30.5	\$147,108	RVE-4	\$3,521	8VM
700	15000	5813VP	30.5	\$137,195	RV-4	5813VP	30.5	\$157,772	RVE-4	\$3,695	8VM
800	15000	5813VP	30.5	\$151,153	RV-4	5813VP	30.5	\$173,826	RVE-4	\$3,979	8VM
900	15000	5813VP	30.5	\$166,012	RV-4	5813VP	30.5	\$190,915	RVE-4	\$4,096	8VM
1000	15000	5813VP	30.5	\$178,319	RV-4	5813VP	30.5	\$205,068	RVE-4	\$4,343	8VM
1250	13100	6811VP	30.5	\$196,291	RV-4	6811VP	30.5	\$225,735	RVE-4	\$5,138	8VM
1500	13100	6811VP	30.5	\$227,526	RV-4	6811VP	30.5	\$261,655	RVE-4	\$6,254	9VM
1750	13100	6813P	30.5	\$263,580	RV-4	6813P	30.5	\$303,117	RVE-4	\$7,296	9VM
2000	13100	6813P	30.5	\$301,228	RV-4	6813P	30.5	\$346,418	RVE-4	\$8,336	9VM
2250	13100	8011PH	42	\$338,887	RV-4	8011PH~	42	\$389,721	RVE-4	\$9,380	9VM
2500	12100	9605PH	42	\$376,540	RV-4	9605PH	42	\$433,023	RVE-4	\$10,420	9VM
3000	12100	9607PH	42	\$422,474	RV-4	9607PH	42	\$485,845	RVE-4	\$11,690	9VM
3500	12100	9608PH	42	\$478,660	RV-4	9608PH	42	\$550,458	RVE-4	\$13,246	9VM

Momentary Upthrust Capacity is 30% of Standard High Thrust Design
+13,200 Lbs. Downthrust for 5012 Frame
~Not for WPII Enclosure
• NRR = Non-Reverse Ratchet
@Contact your Nidec Motor Corporation Technical Representative for WPII frame size confirmation prior to quoting.

See Page M-83 For Available And Alternate BD Dimensions



Three Phase Modifiable Motors
Vertical Solid Shaft
High Thrust - "P" Base
Weather Protected Type I (WPI)
8 Pole, 900 RPM



APPLICATIONS:

For use on Turbine, Mix Flow and Propeller Pumps

FEATURES:

- * Class F Insulation, Class B Rise at Full Load (Sine Wave Power)
- * 1.15 Service Factor (Sine Wave Power)
- * Maximum 40 Deg. C. Ambient, 3,300 Feet Altitude
- * NEMA Design "B"
- * 3 Phase 60 Hz

4000 Volt

HP	Down Thrust (lbs) (#)	Standard Efficient				Premium Efficient				NRR List Adder	Disc. Sym
		Frame	BD (in)	List	Type	Frame	BD (in)	List	Type		
150	12000	449VP@	24.5	\$61,803	RV-4	449VP@	24.5	\$71,070	RVS-4	\$1,995	8VM
200	12000	5008VP	24.5	\$63,650	RV-4	5008VP	24.5	\$73,200	RVE-4	\$2,009	8VM
250	12000	5008VP	24.5	\$73,394	RV-4	5012VP+	24.5	\$84,404	RVE-4	\$2,049	8VM
300	13200	5012VP	24.5	\$83,615	RV-4	5012VP	24.5	\$96,157	RVE-4	\$2,178	8VM
350	13200	5012VP	24.5	\$91,885	RV-4	5012VP	24.5	\$105,667	RVE-4	\$2,366	8VM
400	13200	5012VP	24.5	\$101,561	RV-4	5012VP	24.5	\$116,796	RVE-4	\$2,617	8VM
450	13200	5012VP	24.5	\$110,383	RV-4	5012VP	24.5	\$126,939	RVE-4	\$2,840	8VM
500	13200	5012VP	24.5	\$129,002	RV-4	5012VP	24.5	\$148,354	RVE-4	\$3,516	8VM
600	15000	5813VP	30.5	\$142,725	RV-4	5813VP	30.5	\$164,134	RVE-4	\$3,521	8VM
700	15000	5813VP	30.5	\$151,815	RV-4	5813VP	30.5	\$174,587	RVE-4	\$3,695	8VM
800	15000	5813VP	30.5	\$167,725	RV-4	5813VP	30.5	\$192,885	RVE-4	\$3,979	8VM
900	15000	5813VP	30.5	\$184,216	RV-4	5813VP	30.5	\$211,850	RVE-4	\$4,096	8VM
1000	15000	5813VP	30.5	\$198,871	RV-4	5813VP	30.5	\$228,700	RVE-4	\$4,343	8VM
1250	13100	6811VP	30.5	\$218,756	RV-4	6811VP	30.5	\$251,570	RVE-4	\$5,138	9VM
1500	13100	6811VP	30.5	\$248,993	RV-4	6811VP	30.5	\$286,345	RVE-4	\$6,254	9VM
1750	13100	6813P	30.5	\$284,667	RV-4	6813P	30.5	\$327,366	RVE-4	\$7,296	9VM
2000	13100	6813P	30.5	\$325,331	RV-4	6813P	30.5	\$374,131	RVE-4	\$8,336	9VM
2250	12100	9606PH	42	\$365,998	RV-4	9606PH	42	\$420,899	RVE-4	\$9,380	9VM
2500	12100	9606PH	42	\$406,664	RV-4	9607PH	42	\$467,664	RVE-4	\$10,420	9VM
3000	12100	9607PH	42	\$456,275	RV-4	9607PH	42	\$524,716	RVE-4	\$11,690	9VM
3500	12100	9608PH	42	\$516,955	RV-4	9608PH	42	\$594,498	RVE-4	\$13,246	9VM

Momentary Upthrust Capacity is 30% of Standard High Thrust Design
+ 13,200 Lbs. Downthrust for 5012 Frame
~ Not for WPII Enclosure
• NRR = Non-Reverse Ratchet
@Contact your Nidec Motor Corporation Technical Representative for WPII frame size confirmation prior to quoting.

See Page M-83 For Available And Alternate BD Dimensions



Three Phase Modifiable Motors
Vertical Solid Shaft
High Thrust - "P" Base
Weather Protected Type I (WPI)
10 Pole, 720 RPM



APPLICATIONS:

For use on Turbine, Mix Flow and Propeller Pumps

FEATURES:

- * Class F Insulation, Class B Rise at Full Load (Sine Wave Power)
- * 1.15 Service Factor (Sine Wave Power)
- * Maximum 40 Deg. C. Ambient, 3,300 Feet Altitude
- * NEMA Design "B"
- * 3 Phase 60 Hz

200, 230/460, 575 Volts (&)

HP	Down Thrust (lbs) (#)	Standard Efficient			Premium Efficient			NRR List Adder	Disc. Sym
		Frame	List	Type	Frame	List	Type		
15	8000	326VP	\$6,848	RV-4	326VP	\$8,560	RVS-4	\$685	7VHTM
20	8000	364VP	\$8,023	RV-4	364VP	\$10,029	RVS-4	\$803	7VHTM
25	8000	365VP	\$9,243	RV-4	365VP	\$11,554	RVS-4	\$925	7VHTM
30	9300	404VP	\$10,257	RV-4	404VP	\$12,821	RVS-4	\$1,038	7VHTM
40	9300	405VP	\$12,355	RV-4	405VP	\$15,444	RVS-4	\$1,225	7VHTM
50	13500	H444VP	\$16,037	RV-4	H444VP	\$20,046	RVS-4	\$1,230	7VHTM
60	13500	H445VP	\$18,555	RV-4	H445VP	\$23,194	RVS-4	\$1,526	7VHTM
75	13500	H445VP	\$21,587	RV-4	H445VP	\$26,984	RVS-4	\$1,671	7VHTM
100	13500	447VP@	\$26,984	RV-4	447VP@	\$33,730	RVS-4	\$1,873	7VHTM
125	13500	447VP@	\$30,357	RV-4	447VP@	\$37,946	RVS-4	\$1,897	7VHTM
150	13000	449VP@	\$47,829	RV-4	449VP@	\$55,002	RVE-4	\$2,000	9VM
200	13000	5008VP	\$61,913	RV-4	5008VP	\$71,200	RVE-4	\$2,354	9VM
250	14100	5012VP	\$67,401	RV-4	5012VP	\$77,509	RVE-4	\$2,425	9VM
300	14100	5012VP	\$72,887	RV-4	5012VP	\$83,822	RVE-4	\$2,495	9VM
350	14100	5012VP	\$83,662	RV-4	5012VP	\$96,211	RVE-4	\$2,671	9VM
400	16300	5813VP	\$122,148	RV-4	5813VP	\$140,469	RVE-4	\$3,756	9VM
450	16300	5813VP	\$134,627	RV-4	5813VP	\$154,822	RVE-4	\$4,143	9VM
500	16300	5813VP	\$137,754	RV-4	5813VP	\$158,413	RVE-4	\$4,239	9VM
600	16300	5813VP	\$164,789	RV-4	5813VP	\$189,507	RVE-4	\$5,070	9VM
700	16300	5813VP	\$192,254	RV-4	5813VP	\$221,092	RVE-4	\$6,181	9VM
800	16300	5813VP	\$219,718	RV-4	5813VP	\$252,676	RVE-4	\$6,761	9VM

Momentary Upthrust Capacity is 30% of Standard High Thrust Design
 & Standard Voltages Thru 405 Frame; 444 Frame & Larger, Single Voltage 460 or 575 is standard
 @Contact your Nidec Motor Corporation Technical Representative for WPII frame size confirmation prior to quoting.
 • NRR = Non-Reverse Ratchet

See Page M-83 For Available And Alternate BD Dimensions



Three Phase Modifiable Motors
Vertical Solid Shaft
High Thrust - "P" Base
Weather Protected Type I (WPI)
10 Pole, 720 RPM



APPLICATIONS:

For use on Turbine, Mix Flow and Propeller Pumps

FEATURES:

- * Class F Insulation, Class B Rise at Full Load (Sine Wave Power)
- * 1.15 Service Factor (Sine Wave Power)
- * Maximum 40 Deg. C. Ambient, 3,300 Feet Altitude
- * NEMA Design "B"
- * 3 Phase 60 Hz

2300 Volt

HP	Down Thrust (lbs) (#)	Standard Efficient				Premium Efficient				NRR List Adder	Disc. Sym
		Frame	BD (in)	List	Type	Frame	BD (in)	List	Type		
150	13000	5008VP	24.5	\$56,615	RV-4	5008VP	24.5	\$65,106	RVE-4	\$2,439	9VM
200	13000	5008VP	24.5	\$69,965	RV-4	5008VP	24.5	\$80,460	RVE-4	\$2,439	9VM
250	14100	5012VP	24.5	\$73,477	RV-4	5012VP	24.5	\$84,498	RVE-4	\$2,671	9VM
300	14100	5012VP	24.5	\$84,707	RV-4	5012VP	24.5	\$97,413	RVE-4	\$2,721	9VM
350	14100	5012VP	24.5	\$95,420	RV-4	5012VP	24.5	\$109,732	RVE-4	\$3,070	9VM
400	16300	5813VP	30.5	\$116,427	RV-4	5813VP	30.5	\$133,892	RVE-4	\$3,331	9VM
450	16300	5813VP	30.5	\$128,906	RV-4	5813VP	30.5	\$148,242	RVE-4	\$3,700	9VM
500	16300	5813VP	30.5	\$132,031	RV-4	5813VP	30.5	\$151,833	RVE-4	\$3,793	9VM
600	16300	5813VP	30.5	\$159,068	RV-4	5813VP	30.5	\$183,047	RVE-4	\$4,568	9VM
700	16300	5813VP	30.5	\$159,378	RV-4	5813VP	30.5	\$183,284	RVE-4	\$4,577	9VM
800	16300	5813VP	30.5	\$172,284	RV-4	5813VP	30.5	\$198,124	RVE-4	\$4,948	9VM
900	14100	6810VP	30.5	\$185,477	RV-4	6810VP	30.5	\$213,298	RVE-4	\$5,326	9VM
1000	14100	6811VP	30.5	\$206,972	RV-4	6811VP	30.5	\$238,016	RVE-4	\$5,946	9VM
1250	14100	6813P	30.5	\$238,225	RV-4	6813P	30.5	\$273,958	RVE-4	\$6,556	9VM
1500	14100	6813P	30.5	\$276,333	RV-4	6813P	30.5	\$317,782	RVE-4	\$7,608	9VM
1750	14100	8011PH	42	\$314,446	RV-4	8011PH~	42	\$361,610	RVE-4	\$8,653	9VM
2000	13500	9606PH	42	\$352,566	RV-4	9606PH	42	\$405,448	RVE-4	\$9,892	9VM
2250	13500	9606PH	42	\$395,535	RV-4	9606PH	42	\$454,866	RVE-4	\$11,099	9VM
2500	13500	9607PH	42	\$434,779	RV-4	9607PH	42	\$499,998	RVE-4	\$12,453	9VM

Momentary Upthrust Capacity is 30% of Standard High Thrust Design
 ~ Not For WPII Enclosure
 • NRR = Non-Reverse Ratchet

See Page M-83 For Available And Alternate BD Dimensions



Three Phase Modifiable Motors
Vertical Solid Shaft
High Thrust - "P" Base
Weather Protected Type I (WPI)
10 Pole, 720 RPM



APPLICATIONS:

For use on Turbine, Mix Flow and Propeller Pumps

FEATURES:

- * Class F Insulation, Class B Rise at Full Load (Sine Wave Power)
- * 1.15 Service Factor (Sine Wave Power)
- * Maximum 40 Deg. C. Ambient, 3,300 Feet Altitude
- * NEMA Design "B"
- * 3 Phase 60 Hz

4000 Volt

HP	Down Thrust (lbs) (#)	Standard Efficient				Premium Efficient				NRR List Adder	Disc. Sym
		Frame	BD (in)	List	Type	Frame	BD (in)	List	Type		
150	13000	5008VP	24.5	\$69,185	RV-4	5008VP	24.5	\$79,563	RVE-4	\$2,439	9VM
200	14100	5012VP	24.5	\$79,073	RV-4	5012VP	24.5	\$90,934	RVE-4	\$2,439	9VM
250	14100	5012VP	24.5	\$82,613	RV-4	5012VP	24.5	\$95,002	RVE-4	\$2,671	9VM
300	14100	5012VP	24.5	\$95,160	RV-4	5012VP	24.5	\$109,434	RVE-4	\$2,721	9VM
350	14100	5012VP	24.5	\$107,185	RV-4	5012VP	24.5	\$123,263	RVE-4	\$3,070	9VM
400	16300	5813VP	30.5	\$130,397	RV-4	5813VP	30.5	\$149,955	RVE-4	\$3,331	9VM
450	16300	5813VP	30.5	\$144,373	RV-4	5813VP	30.5	\$166,028	RVE-4	\$3,700	9VM
500	16300	5813VP	30.5	\$147,876	RV-4	5813VP	30.5	\$170,056	RVE-4	\$3,793	9VM
600	16300	5813VP	30.5	\$178,155	RV-4	5813VP	30.5	\$204,878	RVE-4	\$4,568	9VM
700	16300	5813VP	30.5	\$178,505	RV-4	5813VP	30.5	\$205,279	RVE-4	\$4,577	9VM
800	16300	5813VP	30.5	\$192,953	RV-4	5813VP	30.5	\$221,897	RVE-4	\$4,948	9VM
900	14100	6810VP	30.5	\$207,732	RV-4	6810VP	30.5	\$238,892	RVE-4	\$5,326	9VM
1000	14100	6811VP	30.5	\$231,808	RV-4	6811VP	30.5	\$266,580	RVE-4	\$5,946	9VM
1250	14100	6813P	30.5	\$255,751	RV-4	6813P	30.5	\$294,115	RVE-4	\$6,556	9VM
1500	14100	6813P	30.5	\$296,667	RV-4	6813P	30.5	\$341,169	RVE-4	\$7,608	9VM
1750	13500	9606PH	42	\$337,585	RV-4	9606PH	42	\$388,223	RVE-4	\$8,653	9VM
2000	13500	9606PH	42	\$385,786	RV-4	9607PH	42	\$443,653	RVE-4	\$9,892	9VM
2250	13500	9607PH	42	\$434,779	RV-4	9607PH	42	\$499,998	RVE-4	\$11,099	9VM
2500	13500	9608PH	42	\$485,653	RV-4	9608PH	42	\$558,500	RVE-4	\$12,453	9VM

Momentary Upthrust Capacity is 30% of Standard High Thrust Design
 ~ Not For WPII Enclosure
 • NRR = Non-Reverse Ratchet

See Page M-83 For Available And Alternate BD Dimensions



Three Phase Modifiable Motors
Vertical Solid Shaft
High Thrust - "P" Base
Weather Protected Type I (WPI)
12 Pole, 600 RPM



APPLICATIONS:

For use on Turbine, Mix Flow and Propeller Pumps

FEATURES:

- * Class F Insulation, Class B Rise at Full Load (Sine Wave Power)
- * 1.15 Service Factor (Sine Wave Power)
- * Maximum 40 Deg. C. Ambient, 3,300 Feet Altitude
- * NEMA Design "B"
- * 3 Phase 60 Hz

460 or 575 Volt

HP	Down Thrust (lbs)(#)	Standard Efficient			Premium Efficient			NRR List Adder	Disc. Sym
		Frame	List	Type	Frame	List	Type		
10	8500	326VP	\$6,722	RV-4	326VP	\$8,403	RVS-4	\$674	7VHTM
15	8500	364VP	\$8,632	RV-4	364VP	\$10,790	RVS-4	\$857	7VHTM
20	8500	365VP	\$10,029	RV-4	365VP	\$12,536	RVS-4	\$1,002	7VHTM
25	9900	404VP	\$11,431	RV-4	404VP	\$14,289	RVS-4	\$1,155	7VHTM
30	9900	405VP	\$12,821	RV-4	405VP	\$16,026	RVS-4	\$1,293	7VHTM
40	14400	H444VP	\$15,039	RV-4	H444VP	\$18,799	RVS-4	\$1,305	7VHTM
50	14400	H445VP	\$17,560	RV-4	H445VP	\$21,950	RVS-4	\$1,526	7VHTM
60	14400	447VP@	\$24,530	RV-4	447VP@	\$30,663	RVS-4	\$1,789	7VHTM
75	14400	447VP@	\$28,987	RV-4	447VP@	\$36,234	RVS-4	\$1,803	7VHTM
100	13600	449VP@	\$41,427	RV-4	449VP@	\$47,641	RVS-4	\$1,901	9VM
125	13600	449VP@	\$50,054	HV-4	449VP@	\$57,559	RVS-4	\$1,901	9VM
150	13600	5008VP	\$57,535	RV-4	5008VP	\$66,164	RVE-4	\$2,190	9VM
200	15100	5012VP	\$73,070	RV-4	5012VP	\$84,028	RVE-4	\$2,202	9VM
250	15100	5012VP	\$74,789	RV-4	5012VP	\$86,007	RVE-4	\$2,225	9VM
300	15100	5012VP	\$87,465	RV-4	5012VP	\$100,585	RVE-4	\$2,512	9VM
350	17300	5813VP	\$119,695	RV-4	5813VP	\$137,650	RVE-4	\$2,948	9VM
400	17300	5813VP	\$136,359	RV-4	5813VP	\$156,815	RVE-4	\$3,364	9VM
450	17300	5813VP	\$150,751	RV-4	5813VP	\$173,364	RVE-4	\$3,718	9VM
500	17300	5813VP	\$167,230	RV-4	5813VP	\$192,315	RVE-4	\$4,397	9VM

Momentary Upthrust Capacity is 30% of Standard High Thrust Design
 @Contact your Nidec Motor Corporation Technical Representative for WPII frame size confirmation prior to quoting.
 + 15,100 Lbs. Downthrust for 5012 Frame
 • NRR = Non-Reverse Ratchet

See Page M-83 For Available And Alternate BD Dimensions



Three Phase Modifiable Motors
Vertical Solid Shaft
High Thrust - "P" Base
Weather Protected Type I (WPI)
12 Pole, 600 RPM



APPLICATIONS:

For use on Turbine, Mix Flow and Propeller Pumps

FEATURES:

- * Class F Insulation, Class B Rise at Full Load (Sine Wave Power)
- * 1.00 Service Factor (Sine Wave Power) ♦
- * Maximum 40 Deg. C. Ambient, 3,300 Feet Altitude
- * NEMA Design "B"
- * 3 Phase 60 Hz

2300 Volt*

HP	Down Thrust (lbs)(#)	Standard Efficient				Premium Efficient				NRR List Adder	Disc. Sym
		Frame	BD (in)	List	Type	Frame	BD (in)	List	Type		
200	15100	5012VP	24.5	\$81,829	RV-4	5012VP	24.5	\$94,103	RVE-4	\$2,096	9VM
250	15100	5012VP	24.5	\$105,315	RV-4	5012VP	24.5	\$121,113	RVE-4	\$2,700	9VM
300	17300	5813VP	30.5	\$126,552	RV-4	5813VP	30.5	\$145,535	RVE-4	\$3,242	9VM
350	17300	5813VP	30.5	\$136,075	RV-4	5813VP	30.5	\$156,486	RVE-4	\$3,486	9VM
400	17300	5813VP	30.5	\$146,289	RV-4	5813VP	30.5	\$168,230	RVE-4	\$3,751	9VM
450	17300	5813VP	30.5	\$176,136	RV-4	5813VP	30.5	\$202,556	RVE-4	\$4,514	9VM
500	17300	5813VP	30.5	\$189,397	RV-4	5813VP	30.5	\$217,805	RVE-4	\$4,854	9VM
600	15000	6810VP	30.5	\$206,016	RV-4	6810VP	30.5	\$236,920	RVE-4	\$5,279	9VM
700	15000	6810VP	30.5	\$224,505	RV-4	6810VP	30.5	\$258,181	RVE-4	\$5,754	9VM
800	15000	6811VP	30.5	\$242,718	RV-4	6811VP	30.5	\$279,127	RVE-4	\$6,221	9VM
900	15000	6811VP	30.5	\$262,108	RV-4	6811VP	30.5	\$301,423	RVE-4	\$6,716	9VM
1000	15000	6813P	30.5	\$283,401	RV-4	6813P	30.5	\$325,911	RVE-4	\$7,263	9VM
1250	15000	6813P	30.5	\$314,915	RV-4	6813P	30.5	\$362,150	RVE-4	\$8,070	9VM
1500	14700	9607PH	42	\$355,890	RV-4	9607PH	42	\$409,272	RVE-4	\$9,120	9VM

- # Momentary Upthrust Capacity is 30% of Standard High Thrust Design
- ♦ Make Adder for 1.15 Service Factor if Desired
- * Make Special Voltage Adder For 4000 Volts
- NRR = Non-Reverse Ratchet

See Page M-83 For Available And Alternate BD Dimensions



Three Phase Modifiable Motors
Vertical Solid Shaft
High Thrust - "P" Base
Weather Protected Type I (WPI)
14 Pole, 514 RPM



APPLICATIONS:

For use on Turbine, Mix Flow and Propeller Pumps

FEATURES:

- * Class F Insulation, Class B Rise at Full Load (Sine Wave Power)
- * 1.15 Service Factor (Sine Wave Power)
- * Maximum 40 Deg. C. Ambient, 3,300 Feet Altitude
- * NEMA Design "B"
- * 3 Phase 60 Hz

460 or 575 Volt

HP	Down Thrust (lbs) (#)	Standard Efficient				Premium Efficient				NRR List Adder	Disc. Sym
		Frame	BD (in)	List	Type	Frame	BD (in)	List	Type		
100	14200	5008VP	24.5	\$71,322	RV-4	5008VP	24.5	\$82,019	RVE-4	\$1,408	9VM
125	16000	5012VP	24.5	\$75,516	RV-4	5012VP	24.5	\$86,843	RVE-4	\$1,657	9VM
150	16000	5012VP	24.5	\$82,690	RV-4	5012VP	24.5	\$95,094	RVE-4	\$1,887	9VM
200	16000	5012VP	24.5	\$94,354	RV-4	5012VP	24.5	\$108,554	RVE-4	\$2,418	9VM
250	18500	5813VP	30.5	\$103,716	RV-4	5813VP	30.5	\$119,272	RVE-4	\$2,561	9VM
300	18500	5813VP	30.5	\$114,399	RV-4	5813VP	30.5	\$131,559	RVE-4	\$2,932	9VM
350	18500	5813VP	30.5	\$136,000	RV-4	5813VP	30.5	\$156,399	RVE-4	\$3,298	9VM
400	18500	5813VP	30.5	\$149,599	RV-4	5813VP	30.5	\$172,038	RVE-4	\$3,653	9VM
450	18500	5813VP	30.5	\$164,556	RV-4	5813VP	30.5	\$189,239	RVE-4	\$3,979	9VM
500	16000	6810VP	30.5	\$181,012	RV-4	6810VP	30.5	\$208,164	RVE-4	\$4,305	9VM

Momentary Upthrust Capacity is 30% of Standard High Thrust Design
 • NRR = Non-Reverse Ratchet

See Page M-83 For Available And Alternate BD Dimensions



Three Phase Modifiable Motors
Vertical Solid Shaft
High Thrust - "P" Base
Weather Protected Type I (WPI)
14 Pole, 514 RPM



APPLICATIONS:

For use on Turbine, Mix Flow and Propeller Pumps

FEATURES:

- * Class F Insulation, Class B Rise at Full Load (Sine Wave Power)
- * 1.00 Service Factor (Sine Wave Power) ◆
- * Maximum 40 Deg. C. Ambient, 3,300 Feet Altitude
- * NEMA Design "B"
- * 3 Phase 60 Hz

2300 Volt*

HP	Down Thrust (lbs)(#)	Standard Efficient				Premium Efficient				NRR List Adder	Disc. Sym
		Frame	BD (in)	List	Type	Frame	BD (in)	List	Type		
200	16000	5012VP	24.5	\$132,908	RV-4	5012VP	24.5	\$152,847	RVE-4	\$3,404	9VM
250	18500	5813VP	30.5	\$139,847	RV-4	5813VP	30.5	\$160,824	RVE-4	\$3,582	9VM
300	18500	5813VP	30.5	\$156,573	RV-4	5813VP	30.5	\$180,059	RVE-4	\$4,012	9VM
350	18500	5813VP	30.5	\$172,185	RV-4	5813VP	30.5	\$198,014	RVE-4	\$4,413	9VM
400	18500	5813VP	30.5	\$187,796	RV-4	5813VP	30.5	\$215,965	RVE-4	\$4,812	9VM
450	18500	5813VP	30.5	\$203,404	RV-4	5813VP	30.5	\$233,915	RVE-4	\$5,211	9VM
500	16000	6810VP	30.5	\$217,338	RV-4	6810VP	30.5	\$249,939	RVE-4	\$5,570	9VM
600	16000	6810VP	30.5	\$237,087	RV-4	6810VP	30.5	\$272,650	RVE-4	\$6,075	9VM
700	16000	6811VP	30.5	\$258,437	RV-4	6811VP	30.5	\$297,202	RVE-4	\$6,622	9VM
800	16000	6811VP	30.5	\$286,704	RV-4	6811VP	30.5	\$329,709	RVE-4	\$7,347	9VM
900	16000	6813P	30.5	\$310,430	RV-4	6813P	30.5	\$356,993	RVE-4	\$7,955	9VM
1000	16000	6813P	30.5	\$340,272	RV-4	6813P	30.5	\$391,315	RVE-4	\$8,721	9VM
1250	15800	9606PH	42	\$386,352	RV-4	9606PH	42	\$444,305	RVE-4	\$9,901	9VM
1500	15800	9608PH	42	\$419,951	RV-4	9608PH	42	\$482,944	RVE-4	\$10,500	9VM

- # Momentary Upthrust Capacity is 30% of Standard High Thrust Design
- ◆ Make Adder for 1.15 Service Factor if Desired
- * Make Special Voltage Adder For 4000 Volts
- NRR = Non-Reverse Ratchet

See Page M-83 For Available And Alternate BD Dimensions



Three Phase Modifiable Motors
Vertical Solid Shaft
High Thrust - "P" Base
Weather Protected Type I (WPI)
16 Pole, 450 RPM



APPLICATIONS:

For use on Turbine, Mix Flow and Propeller Pumps

FEATURES:

- * Class F Insulation, Class B Rise at Full Load (Sine Wave Power)
- * 1.15 Service Factor (Sine Wave Power)
- * Maximum 40 Deg. C. Ambient, 3,300 Feet Altitude
- * NEMA Design "B"
- * 3 Phase 60 Hz

460 or 575 Volt

HP	Down Thrust (lbs) (#)	Standard Efficient				Premium Efficient				NRR List Adder	Disc. Sym
		Frame	BD (in)	List	Type	Frame	BD (in)	List	Type		
100	16600	5012VP	24.5	\$79,845	RV-4	5012VP	24.5	\$91,822	RVE-4	\$2,045	9VM
125	16600	5012VP	24.5	\$95,045	RV-4	5012VP	24.5	\$109,303	RVE-4	\$2,437	9VM
150	16600	5012VP	24.5	\$111,075	RV-4	5012VP	24.5	\$127,735	RVE-4	\$2,847	9VM
200	19500	5813VP	30.5	\$142,582	RV-4	5813VP	30.5	\$163,969	RVE-4	\$3,653	9VM
250	19500	5813VP	30.5	\$145,089	RV-4	5813VP	30.5	\$166,852	RVE-4	\$3,718	9VM
300	19500	5813VP	30.5	\$166,031	RV-4	5813VP	30.5	\$190,934	RVE-4	\$4,256	9VM
350	19500	5813VP	30.5	\$186,972	RV-4	5813VP	30.5	\$215,019	RVE-4	\$4,791	9VM
400	17000	6810VP	30.5	\$205,669	RV-4	6810VP	30.5	\$236,521	RVE-4	\$5,270	9VM
450	17000	6810VP	30.5	\$224,366	RV-4	6810VP	30.5	\$258,023	RVE-4	\$5,749	9VM
500	17000	6811VP	30.5	\$243,953	RV-4	6811VP	30.5	\$280,547	RVE-4	\$6,251	9VM

Momentary Upthrust Capacity is 30% of Standard High Thrust Design
 • NRR = Non-Reverse Ratchet

See Page M-83 For Available And Alternate BD Dimensions



Three Phase Modifiable Motors
Vertical Solid Shaft
High Thrust - "P" Base
Weather Protected Type I (WPI)
16 Pole, 450 RPM



APPLICATIONS:

For use on Turbine, Mix Flow and Propeller Pumps

FEATURES:

- * Class F Insulation, Class B Rise at Full Load (Sine Wave Power)
- * 1.00 Service Factor (Sine Wave Power) ♦
- * Maximum 40 Deg. C. Ambient, 3,300 Feet Altitude
- * NEMA Design "B"
- * 3 Phase 60 Hz

2300 Volt*

HP	Down Thrust (lbs) (#)	Standard Efficient				Premium Efficient				NRR List Adder	Disc. Sym
		Frame	BD (in)	List	Type	Frame	BD (in)	List	Type		
250	19500	5813VP	30.5	\$165,505	RV-4	5813VP	30.5	\$190,331	RVE-4	\$4,239	9VM
300	19500	5813VP	30.5	\$185,552	RV-4	5813VP	30.5	\$213,383	RVE-4	\$4,754	9VM
350	19500	5813VP	30.5	\$203,542	RV-4	5813VP	30.5	\$234,073	RVE-4	\$5,218	9VM
400	17000	6810VP	30.5	\$221,251	RV-4	6810VP	30.5	\$254,437	RVE-4	\$5,669	9VM
450	17000	6810VP	30.5	\$240,350	RV-4	6810VP	30.5	\$276,404	RVE-4	\$6,481	9VM
500	17000	6811VP	30.5	\$257,045	RV-4	6811VP	30.5	\$295,601	RVE-4	\$6,587	9VM
600	17000	6811VP	30.5	\$282,840	RV-4	6811VP	30.5	\$325,268	RVE-4	\$7,249	9VM
700	17000	6813P	30.5	\$299,420	RV-4	6813P	30.5	\$344,331	RVE-4	\$7,674	9VM
800	16800	9603PH	42	\$332,777	RV-4	9603PH	42	\$382,695	RVE-4	\$8,528	9VM
900	16800	9603PH	42	\$374,378	RV-4	9603PH	42	\$430,535	RVE-4	\$9,592	9VM

Momentary Upthrust Capacity is 30% of Standard High Thrust Design

♦ Make Adder for 1.15 Service Factor if Desired

* Make Special Voltage Adder for 4000 Volts

• NRR = Non-Reverse Ratchet

See Page M-83 For Available And Alternate BD Dimensions



Three Phase Modifiable Motors
Vertical Solid Shaft
High Thrust - "P" Base
Weather Protected Type I (WPI)
18 Pole, 400 RPM



APPLICATIONS:

For use on Turbine, Mix Flow and Propeller Pumps

FEATURES:

- * Class F Insulation, Class B Rise at Full Load (Sine Wave Power)
- * 1.15 Service Factor (Sine Wave Power)
- * Maximum 40 Deg. C. Ambient, 3,300 Feet Altitude
- * NEMA Design "B"
- * 3 Phase 60 Hz

460 or 575 Volt

HP	Down Thrust (lbs) (#)	Standard Efficient				Premium Efficient				NRR List Adder	Disc. Sym
		Frame	BD (in)	List	Type	Frame	BD (in)	List	Type		
250	20300	5813VP	30.5	\$201,286	RV-4	5813VP	30.5	\$231,479	RVE-4	\$4,644	9VM
300	20300	5813VP	30.5	\$223,589	RV-4	5813VP	30.5	\$257,127	RVE-4	\$5,157	9VM
350	18000	6810VP	30.5	\$243,660	RV-4	6810VP	30.5	\$280,209	RVE-4	\$5,620	9VM
400	18000	6810VP	30.5	\$264,434	RV-4	6810VP	30.5	\$304,099	RVE-4	\$6,098	9VM
450	18000	6811VP	30.5	\$282,800	RV-4	6811VP	30.5	\$325,221	RVE-4	\$6,524	9VM
500	18000	6813P	30.5	\$298,296	RV-4	6813P	30.5	\$343,040	RVE-4	\$6,879	9VM
600	18000	6813P	30.5	\$331,357	RV-4	6813P	30.5	\$381,059	RVE-4	\$7,456	9VM
700	17700	9606PH	42	\$351,631	RV-4	9606PH	42	\$404,376	RVE-4	\$8,111	9VM
800	17700	9607PH	42	\$371,559	RV-4	9607PH	42	\$427,291	RVE-4	\$8,569	9VM
900	17700	9607PH	42	\$391,486	RV-4	9607PH	42	\$450,209	RVE-4	\$9,030	9VM

Momentary Upthrust Capacity is 30% of Standard High Thrust Design
 • NRR = Non-Reverse Ratchet

See Page M-83 For Available And Alternate BD Dimensions



Three Phase Modifiable Motors
Vertical Solid Shaft
High Thrust - "P" Base
Weather Protected Type I (WPI)
18 Pole, 400 RPM



APPLICATIONS:

For use on Turbine, Mix Flow and Propeller Pumps

FEATURES:

- * Class F Insulation, Class B Rise at Full Load (Sine Wave Power)
- * 1.0 Service Factor (Sine Wave Power) ♦
- * Maximum 40 Deg. C. Ambient, 3,300 Feet Altitude
- * NEMA Design "B"
- * 3 Phase 60 Hz

2300 Volt

HP	Down Thrust (lbs) (#)	Standard Efficient				Premium Efficient				NRR List Adder	Disc. Sym
		Frame	BD (in)	List	Type	Frame	BD (in)	List	Type		
250	20300	5813VP	30.5	\$201,286	RV-4	5813VP	30.5	\$231,479	RVE-4	\$5,160	9VM
300	20300	5813VP	30.5	\$223,589	RV-4	5813VP	30.5	\$257,127	RVE-4	\$5,730	9VM
350	18000	6810VP	30.5	\$243,660	RV-4	6810VP	30.5	\$280,209	RVE-4	\$6,244	9VM
400	18000	6810VP	30.5	\$264,434	RV-4	6810VP	30.5	\$304,099	RVE-4	\$6,775	9VM
450	18000	6811VP	30.5	\$282,800	RV-4	6811VP	30.5	\$325,221	RVE-4	\$7,249	9VM
500	18000	6813P	30.5	\$298,296	RV-4	6813P	30.5	\$343,040	RVE-4	\$7,643	9VM
600	18000	6813P	30.5	\$331,357	RV-4	6813P	30.5	\$381,059	RVE-4	\$8,284	9VM
700	17700	9606PH	42	\$351,631	RV-4	9606PH	42	\$404,376	RVE-4	\$9,012	9VM
800	17700	9607PH	42	\$371,559	RV-4	9607PH	42	\$427,291	RVE-4	\$9,521	9VM
900	17700	9607PH	42	\$391,486	RV-4	9607PH	42	\$450,209	RVE-4	\$10,033	9VM

Momentary Upthrust Capacity is 30% of Standard High Thrust Design

♦ Make Adder for 1.15 Service Factor if Desired

* Make Special Voltage Adder for 4000 Volts

• NRR = Non-Reverse Ratchet

See Page M-83 For Available And Alternate BD Dimensions



Three Phase Modifiable Motors
Vertical Solid Shaft
High Thrust - "P" Base
Totally Enclosed Fan Cooled (TEFC)
2 Pole, 3600 RPM



APPLICATIONS:

For use on Turbine, Mix Flow and Propeller Pumps

FEATURES:

- * Class F Insulation, Class B Rise at Full Load (Sine Wave Power)
- * 1.00 Service Factor (Sine Wave Power)
- * Maximum 40 Deg. C. Ambient, 3,300 Feet Altitude
- * NEMA Design "B"
- * 3 Phase 60 Hz

200, 230/460, 575 Volts (&)

HP	Down Thrust (lbs)(#)	Standard Efficient			Energy Efficient			Premium Efficient			NRR List Adder	Adder C.L.1 Grp. D. Haz. Loc.	Disc. Sym
		Frame	List	Type	Frame	List	Type	Frame	List	Type			
3	1400	182VP	\$2,214	TV-4	182VP	\$2,679	TVE-4	182VP	\$2,820	TVS-4	\$333	\$643	7VHTM
5	1400	184VP	\$2,237	TV-4	184VP	\$2,737	TVE-4	184VP	\$2,881	TVS-4	\$333	\$634	7VHTM
7.5	2200	213VP	\$2,397	TV-4	213VP	\$2,856	TVE-4	213VP	\$3,006	TVS-4	\$343	\$822	7VHTM
10	2200	215VP	\$2,646	TV-4	215VP	\$3,690	TVE-4	215VP	\$3,884	TVS-4	\$352	\$822	7VHTM
15	2600	254VP	\$2,988	TV-4	254VP	\$4,168	TVE-4	254VP	\$4,387	TVS-4	\$413	\$1,502	7VHTM
20	2600	256VP	\$3,986	TV-4	256VP	\$4,756	TVE-4	256VP	\$5,007	TVS-4	\$446	\$1,502	7VHTM
25	2600	284VP	\$4,456	TV-4	284VP	\$5,297	TVE-4	284VP	\$5,576	TVS-4	\$474	\$2,347	7VHTM
30	2600	286VP	\$4,814	TV-4	286VP	\$5,728	TVE-4	286VP	\$6,030	TVS-4	\$521	\$2,347	7VHTM
40	3400	324VP	\$6,607	TV-4	324VP	\$7,764	TVE-4	324VP	\$8,172	TVS-4	\$648	\$3,192	7VHTM
50	3400	326VP	\$7,429	TV-4	326VP	\$8,741	TVE-4	326VP	\$9,201	TVS-4	\$746	\$3,192	7VHTM
60	3800	364VP	\$9,742	TV-4	364VP	\$12,412	TVE-4	364VP	\$13,065	TVS-4	\$953	\$4,225	7VHTM
75	3800	365VP	\$12,566	TV-4	365VP	\$14,736	TVE-4	365VP	\$15,512	TVS-4	\$1,192	\$4,225	7VHTM
100	3900	405VP	\$16,902	TV-4	405VP	\$19,689	TVE-4	405VP	\$20,725	TVS-4	\$1,718	\$4,930	7VHTM
125	3900	444VP	\$25,142	TV-4	444VP	\$33,902	TVE-4	444VP	\$35,687	TVS-4	\$2,038	\$6,103	7VHTM
150	3900	447VP	\$29,373	TV-4	447VP	\$39,607	TVE-4	447VP	\$41,692	TVS-4	\$2,479	\$7,042	7VHTM
200	7000	449VP	\$52,523	JV-4	449VP	\$57,381	JV-4	449VP	\$60,401	JVE-4	---	N/A	8VM
	7000	5008P	\$61,326	EV-4	5008P	\$67,000	EV-4	5008VP	\$70,526	EVE-4	---	---	8VM
250	7000	449VP	\$58,648	JV-4	449VP	\$64,072	JV-4	449VP	\$67,444	JVE-4	---	N/A	8VM
	7000	5008P	\$67,451	EV-4	5008P	\$73,690	EV-4	5008VP	\$77,568	EVE-4	---	---	8VM
300	7000	449VP	\$76,385	JV-4	449VP	\$83,451	JV-4	449VP	\$87,843	JVE-4	---	N/A	8VM
	7000	5008P	\$87,711	EV-4	5008P	\$95,826	EV-4	5008VP	\$100,869	EVE-4	---	---	8VM
350	7000	5807P	\$91,892	JV-4	5807P	\$100,392	JV-4	5807P	\$105,676	JVE-4	---	N/A	8VM
	7000	5807P	\$104,803	EV-4	5807P	\$114,497	EV-4	5807P	\$120,523	EVE-4	---	---	8VM
400	7000	5807P	\$110,394	JV-4	5807P	\$120,605	JV-4	5807P	\$126,953	JVE-4	---	\$13,469	8VM
450	7000	5809P	\$118,887	JV-4	5809P	\$129,885	JV-4	5809P	\$136,721	JVE-4	---	\$19,484	8VM
500	7000	5811P	\$132,099	JV-4	5811P	\$144,317	JV-4	5811P	\$151,913	JVE-4	---	\$22,007	8VM
600	7000	5811P	\$158,519	JV-4	---	---	---	5811P	\$182,296	JVE-4	---	\$22,007	8VM

Momentary Upthrust Capacity is 30% of Standard High Thrust Design
 & Standard Voltages Thru 405 Frame; 444 Frame & Larger, Single Voltage 460 or 575 Standard
 • NRR = Non-Reverse Ratchet

See Page M-84 For Available And Alternate BD Dimensions

* 60Hz 3600, 1800, 1200 & 900 RPM motors comply with U.S. D.O.E.'s Efficiency regulation 10 CFR Section 431 Subpart B – electric motors (See Page M-80 - M-81 for Nominal Efficiency Table)



† All marks shown within this document are properties of their respective owners.

Three Phase Modifiable Motors
Vertical Solid Shaft
High Thrust - "P" Base
Totally Enclosed Fan Cooled (TEFC)
2 Pole, 3600 RPM



APPLICATIONS:

For use on Turbine, Mix Flow and Propeller Pumps

FEATURES:

- * Class F Insulation, Class B Rise at Full Load (Sine Wave Power)
- * 1.00 Service Factor (Sine Wave Power)
- * Maximum 40 Deg. C. Ambient, 3,300 Feet Altitude
- * NEMA Design "B"
- * 3 Phase 60 Hz

2300 Volt

HP	Down Thrust (lbs) (#)	Standard Efficient				Premium Efficient				NRR List Adder	Adder C.L.1 Grp. D Haz. Loc.	Disc. Sym
		Frame	BD (in)	List	Type	Frame	BD(in)	List	Type			
125*	7000	449VP	24.5	\$57,277	JV-4	449VP	24.5	\$65,869	JVE-4	N/A	N/A	8VM
150	7000	449VP	24.5	\$62,965	JV-4	449VP	24.5	\$72,408	JVE-4	N/A	N/A	8VM
	7000	5008P	24.5	\$72,925	EV-4	5008P	24.5	\$83,864	EVE-4	N/A	---	8VM
200	7000	449VP	24.5	\$75,293	JV-4	449VP	24.5	\$86,587	JVE-4	N/A	N/A	8VM
	7000	5008P	24.5	\$86,927	EV-4	5008P	24.5	\$99,967	EVE-4	N/A	---	8VM
250	7000	449VP	24.5	\$83,242	JV-4	449VP	24.5	\$95,728	JVE-4	N/A	N/A	8VM
	7000	5008P	24.5	\$96,427	EV-4	5008P	24.5	\$110,892	EVE-4	N/A	---	8VM
300	7000	5807P	30.5	\$107,631	JV-4	5807P	30.5	\$123,777	JVE-4	N/A	\$13,469	8VM
350	7000	5807P	30.5	\$125,573	JV-4	5807P	30.5	\$144,408	JVE-4	N/A	\$13,469	8VM
400	7000	5809P	30.5	\$129,754	JV-4	5809P	30.5	\$149,216	JVE-4	N/A	\$19,484	8VM
450	7000	5809P	30.5	\$145,974	JV-4	5809P	30.5	\$167,871	JVE-4	N/A	\$19,484	8VM
500	7000	5811P	30.5	\$154,857	JV-4	5811P	30.5	\$178,085	JVE-4	N/A	\$22,007	8VM
600	7000	5811P	30.5	\$185,829	JV-4	5811P	30.5	\$213,702	JVE-4	N/A	\$22,007	8VM

4160 Volt

HP	Down Thrust (lbs) (#)	Standard Efficient				Premium Efficient				NRR List Adder	Adder C.L.1 Grp. D. Haz. Loc.	Disc. Sym
		Frame	BD (in)	List	Type	Frame	BD(in)	List	Type			
150*	7000	449VP	24.5	\$76,211	JV-4	449VP	24.5	\$87,643	JVE-4	N/A	N/A	8VM
	7000	5008P	24.5	\$86,174	EV-4	5008P	24.5	\$99,101	EVE-4	N/A	---	8VM
200	7000	449VP	24.5	\$90,352	JV-4	449VP	24.5	\$103,906	JVE-4	N/A	N/A	8VM
	7000	5008P	24.5	\$101,986	EV-4	5008P	24.5	\$117,284	EVE-4	N/A	---	8VM
250	7000	5807P	30.5	\$99,059	JV-4	5807P	30.5	\$113,918	JVE-4	N/A	\$13,469	8VM
300	7000	5807P	30.5	\$134,540	JV-4	5807P	30.5	\$154,721	JVE-4	N/A	\$13,469	8VM
350	7000	5809P	30.5	\$140,641	JV-4	5809P	30.5	\$161,735	JVE-4	N/A	\$19,484	8VM
400	7000	5809P	30.5	\$145,324	JV-4	5809P	30.5	\$167,122	JVE-4	N/A	\$19,484	8VM
450	7000	5811P	30.5	\$161,376	JV-4	5811P	30.5	\$185,582	JVE-4	N/A	\$22,007	8VM
500	7000	5811P	30.5	\$200,692	JV-4	5811P	30.5	\$230,796	JVE-4	N/A	\$22,007	8VM

Momentary Upthrust Capacity is 30% of Standard High Thrust Design

* NEMA Design A

• NRR = Non-Reverse Ratchet

See Page M-84 For Available And Alternate BD Dimensions



Three Phase Modifiable Motors
Vertical Solid Shaft
High Thrust - "P" Base
Totally Enclosed Fan Cooled (TEFC)
4 Pole, 1800 RPM



APPLICATIONS:

For use on Turbine, Mix Flow and Propeller Pumps

FEATURES:

- * Class F Insulation, Class B Rise at Full Load (Sine Wave Power)
- * 1.00 Service Factor (Sine Wave Power)
- * Maximum 40 Deg. C. Ambient, 3,300 Feet Altitude
- * NEMA Design "B"
- * 3 Phase 60 Hz

200, 230/460, 575 Volts (&)

HP	Down Thrust (lbs)(#)	Standard Efficient			Energy Efficient			Premium Efficient			NRR List Adder	Adder C.L.1 Grp. D. Haz. Loc.	Disc. Sym
		Frame	List	Type	Frame	List	Type	Frame	List	Type			
3	1800	182VP	\$2,191	TV-4	182VP	\$2,798	TVE-4	182VP	\$2,945	TVS-4	\$333	\$634	7VHTM
5	1800	184VP	\$2,239	TV-4	184VP	\$2,859	TVE-4	184VP	\$3,009	TVS-4	\$333	\$634	7VHTM
7.5	2500	213VP	\$2,344	TV-4	213VP	\$2,982	TVE-4	213VP	\$3,139	TVS-4	\$343	\$822	7VHTM
10	2500	215VP	\$2,576	TV-4	215VP	\$3,854	TVE-4	215VP	\$4,057	TVS-4	\$352	\$822	7VHTM
15	3300	254VP	\$3,724	TV-4	254VP	\$4,447	TVE-4	254VP	\$4,681	TVS-4	\$423	\$1,502	7VHTM
20	3300	256VP	\$4,155	TV-4	256VP	\$4,966	TVE-4	256VP	\$5,227	TVS-4	\$488	\$1,502	7VHTM
25	3300	284VP	\$4,728	TV-4	284VP	\$5,642	TVE-4	284VP	\$5,938	TVS-4	\$545	\$2,347	7VHTM
30	3300	286VP	\$5,218	TV-4	286VP	\$6,235	TVE-4	286VP	\$6,564	TVS-4	\$610	\$2,347	7VHTM
40	4500	324VP	\$6,703	TV-4	324VP	\$7,891	TVE-4	324VP	\$8,306	TVS-4	\$681	\$3,192	7VHTM
50	4500	326VP	\$7,748	TV-4	326VP	\$9,138	TVE-4	326VP	\$9,619	TVS-4	\$808	\$3,192	7VHTM
60	5600	364VP	\$9,693	TV-4	364VP	\$11,920	TVE-4	364VP	\$12,547	TVS-4	\$1,000	\$4,225	7VHTM
75	5600	365VP	\$11,486	TV-4	365VP	\$13,558	TVE-4	365VP	\$14,271	TVS-4	\$1,211	\$4,225	7VHTM
100	7000	405VP	\$15,561	TV-4	405VP	\$18,166	TVE-4	405VP	\$19,122	TVS-4	\$1,634	\$4,930	7VHTM
125	9300	444VP	\$22,261	TV-4	444VP	\$25,483	TVE-4	444VP	\$26,824	TVS-4	\$1,869	\$6,103	7VHTM
150	9300	447VP	\$26,215	TV-4	447VP	\$30,072	TVE-4	447VP	\$31,654	TVS-4	\$2,282	\$7,042	7VHTM
200	9300	447VP	\$34,893	TV-4	447VP	\$40,139	TVE-4	447VP	\$42,252	TVS-4	\$3,188	\$7,042	7VHTM
250	8800	449VP	\$54,714	JV-4	449VP	\$59,774	JV-4	449VP	\$62,920	JVE-4	\$1,352	N/A	8VM
	8800	5008P	\$68,066	EV-4	5008P	\$74,361	EV-4	5008P	\$78,275	EVE-4	\$1,352	---	8VM
300	8800	449VP	\$60,434	JV-4	449VP	\$66,025	JV-4	449VP	\$69,500	JVE-4	\$1,512	N/A	8VM
	8800	5008P	\$70,998	EV-4	5008P	\$77,566	EV-4	5008P	\$81,648	EVE-4	\$1,512	---	8VM
350	8800	449VP	\$71,380	JV-4	449VP	\$77,983	JV-4	449VP	\$82,087	JVE-4	\$1,784	N/A	8VM
	8800	5008P	\$82,707	EV-4	5008P	\$90,357	EV-4	5008P	\$95,113	EVE-4	\$1,784	---	8VM
400	9500	5807P	\$80,833	JV-4	5807P	\$88,310	JV-4	5807P	\$92,958	JVE-4	\$1,873	\$11,326	8VM
450	9500	5807P	\$90,831	JV-4	5807P	\$99,232	JV-4	5807P	\$104,455	JVE-4	\$1,873	\$13,469	8VM
500	9500	5809P	\$100,552	JV-4	5809P	\$109,852	JV-4	5809P	\$115,634	JVE-4	\$1,981	\$15,549	8VM
600	9500	5811P	\$146,160	JV-4	---	---	---	5811P	\$168,082	JVE-4	\$2,408	\$22,007	8VM
700	9300	5812VP	\$165,160	JV-4	---	---	---	5812VP	\$189,932	JVE-4	\$2,650	\$22,007	8VM
800	9300	5812VP	\$189,720	JV-4	---	---	---	5812VP	\$218,178	JVE-4	\$3,045	N/A	8VM

Momentary Upthrust Capacity is 30% of Standard High Thrust Design
 & Standard Voltages Thru 405 Frame; 444 Frame & Larger, Single Voltage 460 or 575 Standard
 • NRR = Non-Reverse Ratchet

See Page M-84 For Available And Alternate BD Dimensions

* 60Hz 3600, 1800, 1200 & 900 RPM motors comply with U.S. D.O.E.'s Efficiency regulation 10 CFR Section 431 Subpart B – electric motors (See Page M-80 - M-81 for Nominal Efficiency Table)



† All marks shown within this document are properties of their respective owners.

Three Phase Modifiable Motors
Vertical Solid Shaft
High Thrust - "P" Base
Totally Enclosed Fan Cooled (TEFC)
4 Pole, 1800 RPM

VSS-HT
TEFC
1800 RPM
2300V/4160V

APPLICATIONS:

For use on Turbine, Mix Flow and Propeller Pumps

FEATURES:

- * Class F Insulation, Class B Rise at Full Load (Sine Wave Power)
- * 1.00 Service Factor (Sine Wave Power)
- * Maximum 40 Deg. C. Ambient, 3,300 Feet Altitude
- * NEMA Design "B"
- * 3 Phase 60 Hz

2300 Volt

HP	Down Thrust (lbs) (#)	Standard Efficient				Premium Efficient				NRR List Adder	Adder C.L.1 Grp. D. Haz. Loc.	Disc. Sym
		Frame	BD (in)	List	Type	Frame	BD(in)	List	Type			
150	8800	449VP	24.5	\$55,495	JV-4	449VP	24.5	\$63,819	JVE-4	\$1,387	N/A	8VM
	8800	5008P	24.5	\$62,146	EV-4	5008P	24.5	\$71,467	EVE-4	\$1,387	---	8VM
200	8800	449VP	24.5	\$61,373	JV-4	449VP	24.5	\$70,580	JVE-4	\$1,535	N/A	8VM
	8800	5008P	24.5	\$69,045	EV-4	5008P	24.5	\$79,401	EVE-4	\$1,535	---	8VM
250	8800	449VP	24.5	\$68,944	JV-4	449VP	24.5	\$79,286	JVE-4	\$1,723	N/A	8VM
	8800	5008P	24.5	\$79,507	EV-4	5008P	24.5	\$91,434	EVE-4	\$1,723	---	8VM
300	9500	5807P	30.5	\$77,559	JV-4	5807P	30.5	\$89,192	JVE-4	\$1,854	\$10,563	8VM
350	9500	5807P	30.5	\$89,366	JV-4	5807P	30.5	\$102,772	JVE-4	\$1,854	\$13,469	8VM
400	9500	5807P	30.5	\$99,390	JV-4	5809P	30.5	\$114,298	JVE-4	\$2,061	\$13,469	8VM
450	9500	5809P	30.5	\$110,901	JV-4	5809P	30.5	\$127,535	JVE-4	\$2,286	\$19,484	8VM
500	9500	5809P	30.5	\$123,239	JV-4	5809P	30.5	\$141,725	JVE-4	\$2,627	\$19,484	8VM
600	9500	5811P	30.5	\$147,887	JV-4	5811P	30.5	\$170,070	JVE-4	\$3,134	\$22,007	8VM
700	9300	5812P	30.5	\$172,535	JV-4	5812P	30.5	\$198,415	JVE-4	\$4,573	N/A	8VM
800	9300	5812P	30.5	\$189,720	JV-4	5812P	30.5	\$218,178	JVE-4	\$5,170	N/A	8VM
900	9300	5812P	30.5	\$201,229	JV-4	5812P	30.5	\$231,413	JVE-4	\$5,484	N/A	8VM
1000	9300	5812P	30.5	\$212,138	JV-4	5812P	30.5	\$243,959	JVE-4	\$5,780	N/A	8VM
1250**	9300	5812P	30.5	\$237,143	JV-4	5812P	30.5	\$272,715	JVE-4	\$6,462	N/A	8VM
1500	10900	6812VPA	36	\$258,486	JV-4	6812VPA	36	\$297,259	JVE-4	\$7,108	N/A	9VM
1750	10900	6812VPA	36	\$281,750	JV-4	6812VPA	36	\$324,013	JVE-4	\$7,819	N/A	9VM
2000**	10900	6812VPA	36	\$307,107	JV-4	6812VPA	36	\$353,173	JVE-4	\$8,601	N/A	9VM

4160 Volt

HP	Down Thrust (lbs) (#)	Standard Efficient				Premium Efficient				NRR List Adder	Adder C.L.1 Grp. D. Haz. Loc.	Disc. Sym
		Frame	BD (in)	List	Type	Frame	BD(in)	List	Type			
150	8800	449VP	24.5	\$59,660	JV-4	449VP	24.5	\$68,608	JVE-4	\$1,387	N/A	8VM
	8800	5008P	24.5	\$66,310	EV-4	5008P	24.5	\$76,256	EVE-4	\$1,387	---	8VM
200	8800	449VP	24.5	\$65,977	JV-4	449VP	24.5	\$75,873	JVE-4	\$1,535	N/A	8VM
	8800	5008P	24.5	\$73,648	EV-4	5008P	24.5	\$84,695	EVE-4	\$1,535	---	8VM
250	9500	5807P	30.5	\$74,115	JV-4	5807P	24.5	\$85,230	JVE-4	\$1,723	N/A	8VM
	9500	5807P	30.5	\$84,678	EV-4	5807P	24.5	\$97,380	EVE-4	\$1,723	---	8VM
300	9500	5807P	30.5	\$83,376	JV-4	5807P	30.5	\$95,880	JVE-4	\$1,854	\$10,563	8VM
350	9500	5807P	30.5	\$96,068	JV-4	5807P	30.5	\$110,479	JVE-4	\$1,854	\$13,469	8VM
400	9500	5809P	30.5	\$105,352	JV-4	5809P	30.5	\$121,155	JVE-4	\$2,061	\$13,469	8VM
450	9500	5809P	30.5	\$117,556	JV-4	5809P	30.5	\$135,190	JVE-4	\$2,286	\$19,484	8VM
500	9500	5811P	30.5	\$130,840	JV-4	5811P	30.5	\$150,465	JVE-4	\$2,627	\$19,484	8VM
600	9500	5811P	30.5	\$157,007	JV-4	5811P	30.5	\$180,559	JVE-4	\$3,134	\$22,007	8VM
700	9300	5812P	30.5	\$186,338	JV-4	5812P	30.5	\$214,289	JVE-4	\$4,573	N/A	8VM
800	9300	5812P	30.5	\$199,205	JV-4	5812P	30.5	\$229,086	JVE-4	\$5,170	N/A	8VM
900	9300	5812P	30.5	\$211,290	JV-4	5812P	30.5	\$242,984	JVE-4	\$5,484	N/A	8VM
1000	9300	5812P	30.5	\$222,745	JV-4	5812P	30.5	\$256,157	JVE-4	\$5,780	N/A	8VM
1250**	9300	5812P	30.5	\$249,000	JV-4	5812P	30.5	\$286,350	JVE-4	\$6,462	N/A	8VM
1500	10900	6812VPA	36	\$271,410	JV-4	6812VPA	36	\$312,122	JVE-4	\$6,850	N/A	9VM
1750	10900	6812VPA	36	\$295,837	JV-4	6812VPA	36	\$340,213	JVE-4	\$7,261	N/A	9VM
2000**	10900	6812VPA	36	\$322,462	JV-4	6812VPA	36	\$370,831	JVE-4	\$7,696	N/A	9VM

Momentary Upthrust Capacity is 30% of Standard High Thrust Design

** Class B rise by embedded detector at 1.0 Service Factor. Price includes 100 ohm winding Resistance Temperature Detectors

• NRR = Non-Reverse Ratchet SRC = Self Release Coupling

See Page M-84 For Available And Alternate BD Dimensions



† All marks shown within this document are properties of their respective owners.

Three Phase Modifiable Motors
Vertical Solid Shaft
High Thrust - "P" Base
Totally Enclosed Fan Cooled (TEFC)
6 Pole, 1200 RPM



APPLICATIONS:

For use on Turbine, Mix Flow and Propeller Pumps

FEATURES:

- * Class F Insulation, Class B Rise at Full Load (Sine Wave Power)
- * 1.00 Service Factor (Sine Wave Power)
- * Maximum 40 Deg. C. Ambient, 3,300 Feet Altitude
- * NEMA Design "B"
- * 3 Phase 60 Hz

200, 230/460, 575 Volts (&)

HP	Down Thrust (lbs)(#)	Standard Efficient			Energy Efficient			Premium Efficient			NRR List Adder	Adder C.L.1 Grp. D. Haz. Loc.	Disc. Sym
		Frame	List	Type	Frame	List	Type	Frame	List	Type			
2	2000	184VP	\$2,548	TV-4	184VP	\$2,799	TVE-4	184VP	\$2,946	TVS-4	\$286	\$634	7VHTM
3	2900	213VP	\$2,716	TV-4	213VP	\$3,239	TVE-4	213VP	\$3,410	TVS-4	\$291	\$822	7VHTM
5	2900	215VP	\$3,478	TV-4	215VP	\$4,140	TVE-4	215VP	\$4,358	TVS-4	\$394	\$822	7VHTM
7.5	3800	254VP	\$4,025	TV-4	254VP	\$4,799	TVE-4	254VP	\$5,051	TVS-4	\$469	\$1,502	7VHTM
10	3800	256VP	\$4,577	TV-4	256VP	\$5,456	TVE-4	256VP	\$5,743	TVS-4	\$488	\$1,502	7VHTM
15	3800	284VP	\$5,432	TV-4	284VP	\$6,464	TVE-4	284VP	\$6,804	TVS-4	\$568	\$2,347	7VHTM
20	3800	286VP	\$6,397	TV-4	286VP	\$7,631	TVE-4	286VP	\$8,032	TVS-4	\$690	\$2,347	7VHTM
25	5100	324VP	\$8,039	TV-4	324VP	\$9,445	TVE-4	324VP	\$9,942	TVS-4	\$761	\$3,192	7VHTM
30	5100	326VP	\$9,001	TV-4	326VP	\$10,590	TVE-4	326VP	\$11,147	TVS-4	\$864	\$3,192	7VHTM
40	6400	364VP	\$12,365	TV-4	364VP	\$14,501	TVE-4	364VP	\$15,265	TVS-4	\$1,136	\$4,225	7VHTM
50	6400	365VP	\$14,185	TV-4	365VP	\$16,665	TVE-4	365VP	\$17,542	TVS-4	\$1,338	\$4,225	7VHTM
60	8000	404VP	\$17,656	TV-4	404VP	\$20,495	TVE-4	404VP	\$21,573	TVS-4	\$1,634	\$4,930	7VHTM
75	8000	405VP	\$20,227	TV-4	405VP	\$25,292	TVE-4	405VP	\$26,623	TVS-4	\$1,915	\$4,930	7VHTM
100	10600	444VP	\$27,978	TV-4	444VP	\$31,047	TVE-4	444VP	\$32,681	TVS-4	\$2,925	\$6,103	7VHTM
125	10600	447VP	\$32,839	TV-4	447VP	\$37,641	TVE-4	447VP	\$39,623	TVS-4	\$3,371	\$7,042	7VHTM
150	10600	447VP	\$40,215	TV-4	447VP	\$46,138	TVE-4	447VP	\$48,566	TVS-4	\$3,371	\$7,042	7VHTM
200	10000	449VP	\$69,521	JV-4	449VP	\$75,953	JV-4	449VP	\$79,951	JVE-4	\$1,967	N/A	8VM
	10000	5008P	\$79,822	EV-4	5008P	\$87,206	EV-4	5008P	\$91,796	EVE-4	\$1,967	---	8VM
250	10000	449VP	\$73,469	JV-4	449VP	\$80,264	JV-4	449VP	\$84,488	JVE-4	\$2,077	N/A	8VM
	10000	5008P	\$85,291	EV-4	5008P	\$93,183	EV-4	5008P	\$98,087	EVE-4	\$2,077	---	8VM
300	10000	449VP	\$87,214	JV-4	449VP	\$95,278	JV-4	449VP	\$100,293	JVE-4	\$2,077	N/A	8VM
	11000	5807P	\$98,540	EV-4	5807P	\$107,658	EV-4	5807P	\$113,324	EVE-4	\$2,077	---	8VM
350	11000	5807P	\$101,610	JV-4	5807P	\$111,009	JV-4	5807P	\$116,852	JVE-4	\$2,096	\$13,469	8VM
400	11000	5807P	\$117,298	JV-4	5807P	\$128,147	JV-4	5807P	\$134,892	JVE-4	\$2,406	\$13,469	8VM
450	11000	5809P	\$133,070	JV-4	5809P	\$142,814	JV-4	5809P	\$150,331	JVE-4	\$2,709	\$19,484	8VM
500	11000	5809P	\$145,246	JV-4	5809P	\$158,681	JV-4	5809P	\$167,033	JVE-4	\$3,007	\$19,484	8VM
600	11000	5811P	\$174,296	JV-4	---	---	---	5811P	\$200,441	JVE-4	\$3,610	\$22,007	8VM
700	10600	5812P	\$188,260	JV-4	---	---	---	5812P	\$216,499	JVE-4	\$3,900	N/A	8VM

Momentary Upthrust Capacity is 30% of Standard High Thrust Design
 & Standard Voltages Thru 405 Frame; 444 Frame & Larger, Single Voltage 460 or 575 is standard
 • NRR = Non-Reverse Ratchet

See Page M-84 For Available And Alternate BD Dimensions

* 60Hz 3600, 1800, 1200 & 900 RPM motors comply with U.S. D.O.E.'s Efficiency regulation 10 CFR Section 431 Subpart B – electric motors (See Page M-80 - M-81 for Nominal Efficiency Table)



† All marks shown within this document are properties of their respective owners.

Three Phase Modifiable Motors
Vertical Solid Shaft
High Thrust - "P" Base
Totally Enclosed Fan Cooled (TEFC)
6 Pole, 1200 RPM



APPLICATIONS:

For use on Turbine, Mix Flow and Propeller Pumps

FEATURES:

- * Class F Insulation, Class B Rise at Full Load (Sine Wave Power)
- * 1.00 Service Factor (Sine Wave Power)
- * Maximum 40 Deg. C. Ambient, 3,300 Feet Altitude

- * NEMA Design "B"
- * 3 Phase 60 Hz

2300 Volt

HP	Down Thrust (lbs) (#)	Standard Efficient				Premium Efficient				NRR List Adder	Adder C.L.1 Grp. D. Haz. Loc.	Disc. Sym
		Frame	BD (in)	List	Type	Frame	BD(in)	List	Type			
125	10000	449VP	24.5	\$62,275	JV-4	449VP	24.5	\$71,615	JVE-4	\$2,174	N/A	8VM
	10000	5008P	24.5	\$68,923	EV-4	5008P	24.5	\$79,261	EVE-4	\$2,174	---	8VM
150	10000	449VP	24.5	\$66,784	JV-4	449VP	24.5	\$76,803	JVE-4	\$2,174	N/A	8VM
	10000	5008P	24.5	\$74,455	EV-4	5008P	24.5	\$85,624	EVE-4	\$2,174	---	8VM
200	10000	449VP	24.5	\$82,582	JV-4	449VP	24.5	\$94,969	JVE-4	\$2,174	N/A	8VM
	10000	5008P	24.5	\$91,700	EV-4	5008P	24.5	\$105,455	EVE-4	\$2,174	---	8VM
250	11000	5807P	30.5	\$93,026	JV-4	5807P	30.5	\$106,977	JVE-4	\$2,200	\$11,326	8VM
300	11000	5807P	30.5	\$107,700	JV-4	5807P	30.5	\$123,854	JVE-4	\$2,225	\$13,469	8VM
350	11000	5807P	30.5	\$120,986	JV-4	5807P	30.5	\$139,134	JVE-4	\$2,261	\$13,469	8VM
400	11000	5809P	30.5	\$134,509	JV-4	5809P	30.5	\$154,685	JVE-4	\$2,406	\$19,484	8VM
450	11000	5809P	30.5	\$154,636	JV-4	5809P	30.5	\$177,831	JVE-4	\$2,918	\$19,484	8VM
500	11000	5811P	30.5	\$176,286	JV-4	5811P	30.5	\$202,728	JVE-4	\$3,324	\$19,484	8VM
600	10600	5812P	30.5	\$202,730	JV-4	5812P	30.5	\$233,138	JVE-4	\$3,824	N/A	8VM
700	10600	5812P	30.5	\$218,405	JV-4	5812P	30.5	\$251,166	JVE-4	\$5,952	N/A	8VM
800**	10600	5812P	30.5	\$234,436	JV-4	5812P	30.5	\$269,601	JVE-4	\$6,388	N/A	8VM
900	13700	6812VPA	36	\$247,512	JV-4	6812VPA	36	\$284,639	JVE-4	\$6,771	N/A	9VM
1000	13700	6812VPA	36	\$260,930	JV-4	6812VPA	36	\$300,070	JVE-4	\$7,178	N/A	9VM
1250	13700	6812VPA	36	\$291,686	JV-4	6812VPA	36	\$335,439	JVE-4	\$7,608	N/A	9VM

4160 Volt

HP	Down Thrust (lbs) (#)	Standard Efficient				Premium Efficient				NRR List Adder	Adder C.L.1 Grp. D. Haz. Loc.	Disc. Sym
		Frame	BD (in)	List	Type	Frame	BD(in)	List	Type			
150	10000	449VP	24.5	\$79,472	JV-4	449VP	24.5	\$91,392	JVE-4	\$2,174	N/A	8VM
	10000	5008P	24.5	\$87,143	EV-4	5008P	24.5	\$100,214	EVE-4	\$2,174	---	8VM
200	11000	5807P	30.5	\$93,901	JV-4	5807P	30.5	\$107,986	JVE-4	\$2,174	N/A	8VM
	11000	5807P	30.5	\$103,016	EV-4	5807P	30.5	\$118,469	EVE-4	\$2,174	---	8VM
250	11000	5807P	30.5	\$99,791	JV-4	5807P	30.5	\$114,761	JVE-4	\$2,200	\$11,326	8VM
300	11000	5807P	30.5	\$114,162	JV-4	5807P	30.5	\$131,284	JVE-4	\$2,225	\$13,469	8VM
350	11000	5807P	30.5	\$128,404	JV-4	5807P	30.5	\$147,664	JVE-4	\$2,261	\$13,469	8VM
400	11000	5809P	30.5	\$142,580	JV-4	5809P	30.5	\$163,967	JVE-4	\$2,406	\$19,484	8VM
450	11000	5811P	30.5	\$163,915	JV-4	5811P	30.5	\$188,502	JVE-4	\$2,918	\$19,484	8VM
500	11000	5811P	30.5	\$186,864	JV-4	5811P	30.5	\$214,892	JVE-4	\$3,324	\$19,484	8VM
600	10600	5812P	30.5	\$214,894	JV-4	5812P	30.5	\$247,129	JVE-4	\$3,824	N/A	8VM
700	10600	5812P	30.5	\$229,325	JV-4	5812P	30.5	\$263,724	JVE-4	\$5,952	N/A	8VM
800**	10600	5812P	30.5	\$246,158	JV-4	5812P	30.5	\$283,082	JVE-4	\$6,388	N/A	8VM
900	13700	6812VPA	36	\$260,943	JV-4	6812VPA	36	\$300,084	JVE-4	\$6,771	N/A	9VM
1000	13700	6812VPA	36	\$273,976	JV-4	6812VPA	36	\$315,072	JVE-4	\$7,178	N/A	9VM
1250	13700	6812VPA	36	\$306,270	JV-4	6812VPA	36	\$352,211	JVE-4	\$7,608	N/A	9VM

Momentary Upthrust Capacity is 30% of Standard High Thrust Design

** Class B rise by embedded detector at 1.0 Service Factor. Price includes 100 ohm winding Resistance Temperature Detectors

• NRR = Non-Reverse Ratchet SRC = Self Release Coupling

See Page M-84 For Available And Alternate BD Dimensions



† All marks shown within this document are properties of their respective owners.

Three Phase Modifiable Motors
Vertical Solid Shaft
High Thrust - "P" Base
Totally Enclosed Fan Cooled (TEFC)
8 Pole, 900 RPM



APPLICATIONS:

For use on Turbine, Mix Flow and Propeller Pumps

FEATURES:

- * Class F Insulation, Class B Rise at Full Load (Sine Wave Power)
- * 1.00 Service Factor (Sine Wave Power)
- * Maximum 40 Deg. C. Ambient, 3,300 Feet Altitude
- * NEMA Design "B"
- * 3 Phase 60 Hz

200, 230/460, 575 Volts (&)

HP	Down Thrust (lbs)(#)	Standard Efficient			Energy Efficient			Premium Efficient			NRR List Adder	Adder C.L.1 Grp. D. Haz. Loc.	Disc. Sym
		Frame	List	Type	Frame	List	Type	Frame	List	Type			
1.5	2000	184VP	\$2,157	TV-4	184VP	\$2,839	TVE-4	184VP	\$2,989	TVS-4	\$286	\$634	7VHTM
2	3200	213VP	\$2,384	TV-4	213VP	\$3,097	TVE-4	213VP	\$3,260	TVS-4	\$291	\$822	7VHTM
3	3200	215VP	\$2,887	TV-4	215VP	\$3,423	TVE-4	215VP	\$3,603	TVS-4	\$385	\$822	7VHTM
5	4200	254VP	\$4,162	TV-4	254VP	\$4,951	TVE-4	254VP	\$5,212	TVS-4	\$469	\$1,502	7VHTM
7.5	4200	256VP	\$4,681	TV-4	256VP	\$5,578	TVE-4	256VP	\$5,872	TVS-4	\$540	\$1,502	7VHTM
10	4200	284VP	\$5,830	TV-4	284VP	\$6,945	TVE-4	284VP	\$7,310	TVS-4	\$540	\$2,347	7VHTM
15	4200	286VP	\$6,501	TV-4	286VP	\$7,754	TVE-4	286VP	\$8,162	TVS-4	\$704	\$2,347	7VHTM
20	5600	324VP	\$8,282	TV-4	324VP	\$9,735	TVE-4	324VP	\$10,247	TVS-4	\$784	\$3,192	7VHTM
25	5600	326VP	\$9,348	TV-4	326VP	\$10,999	TVE-4	326VP	\$11,578	TVS-4	\$894	\$3,192	7VHTM
30	7000	364VP	\$11,223	TV-4	364VP	\$14,013	TVE-4	364VP	\$14,750	TVS-4	\$1,089	\$4,225	7VHTM
40	7000	365VP	\$13,953	TV-4	365VP	\$16,390	TVE-4	365VP	\$17,253	TVS-4	\$1,310	\$4,225	7VHTM
50	8800	404VP	\$17,345	TV-4	404VP	\$20,128	TVE-4	404VP	\$21,187	TVS-4	\$1,596	\$4,930	7VHTM
60	8800	405VP	\$19,735	TV-4	405VP	\$22,706	TVE-4	405VP	\$23,901	TVS-4	\$1,840	\$4,930	7VHTM
75	11700	444VP	\$25,792	TV-4	444VP	\$29,486	TVE-4	444VP	\$31,038	TVS-4	\$2,033	\$6,103	7VHTM
100	11700	447VP	\$32,907	TV-4	447VP	\$37,722	TVE-4	447VP	\$39,707	TVS-4	\$2,718	\$7,042	7VHTM
125	11700	447VP	\$43,187	TV-4	447VP	\$48,626	TVE-4	447VP	\$51,185	TVS-4	\$2,718	\$7,042	7VHTM
150	11000	449VP	\$69,326	JV-4	449VP	\$75,737	JV-4	449VP	\$79,723	JVE-4	\$1,674	N/A	8VM
	11000	5008P	\$79,009	EV-4	5008P	\$86,319	EV-4	5008P	\$90,862	EVE-4	\$1,674	---	8VM
200	11000	449VP	\$80,596	JV-4	449VP	\$88,051	JV-4	449VP	\$92,685	JVE-4	\$1,674	N/A	8VM
	11000	5008P	\$90,467	EV-4	5008P	\$98,836	EV-4	5008P	\$104,038	EVE-4	\$1,674	---	8VM
250	11000	449VP	\$90,500	JV-4	449VP	\$98,869	JV-4	449VP	\$104,073	JVE-4	\$1,878	N/A	8VM
	12300	5807P	\$101,826	EV-4	5807P	\$111,246	EV-4	5807P	\$117,101	EVE-4	\$1,878	---	8VM
300	12300	5807P	\$107,589	JV-4	5807P	\$117,539	JV-4	5807P	\$123,725	JVE-4	\$2,690	\$13,465	8VM
350	12300	5807P	\$125,653	JV-4	5807P	\$137,275	JV-4	5807P	\$144,500	JVE-4	\$3,143	\$13,465	8VM
400	12300	5809P	\$143,603	JV-4	5809P	\$156,886	JV-4	5809P	\$165,143	JVE-4	\$3,671	\$19,484	8VM
450	12300	5809P	\$158,451	JV-4	5809P	\$173,107	JV-4	5809P	\$182,218	JVE-4	\$4,038	\$19,484	8VM
500	12300	5811P	\$179,505	JV-4	5811P	\$196,109	JV-4	5811P	\$206,430	JVE-4	\$4,587	\$22,007	8VM
600	11700	5812P	\$202,840	JV-4	---	---	---	5812P	\$233,226	JVE-4	\$5,153	N/A	8VM
700	15000	6812VPA	\$229,209	JV-4	---	---	---	6812VPA	\$263,590	JVE-4	\$5,563	N/A	9VM
800	15000	6812VPA	\$259,006	JV-4	---	---	---	6812VPA	\$297,857	JVE-4	\$6,146	N/A	9VM

Momentary Upthrust Capacity is 30% of Standard High Thrust Design
 & Standard Voltages Thru 405 Frame; 444 Frame & Larger, Single Voltage 460 or 575 is standard
 • NRR = Non-Reverse Ratchet
 See Page M-84 For Available And Alternate BD Dimensions
 * 60Hz 3600, 1800, 1200 & 900 RPM motors comply with U.S. D.O.E.'s Efficiency regulation 10 CFR Section 431 Subpart B – electric motors (See Page M-80 - M-81 for Nominal Efficiency Table)



† All marks shown within this document are properties of their respective owners.

Three Phase Modifiable Motors
Vertical Solid Shaft
High Thrust - "P" Base
Totally Enclosed Fan Cooled (TEFC)
8 Pole, 900 RPM

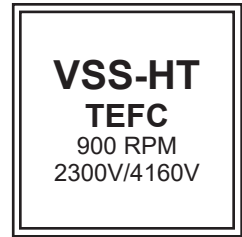

APPLICATIONS:

For use on Turbine, Mix Flow and Propeller Pumps

FEATURES:

- * Class F Insulation, Class B Rise at Full Load (Sine Wave Power)
- * 1.00 Service Factor (Sine Wave Power)
- * Maximum 40 Deg. C. Ambient, 3,300 Feet Altitude
- * NEMA Design "B"
- * 3 Phase 60 Hz

2300 Volt

HP	Down Thrust (lbs) (#)	Standard Efficient				Premium Efficient				NRR List Adder	Adder C.L.1 Grp. D. Haz.Loc.	Disc. Sym
		Frame	BD (in)	List	Type	Frame	BD(in)	List	Type			
125	11000	449VP	24.5	\$74,303	JV-4	449VP	24.5	\$85,446	JVE-4	\$1,955	N/A	8VM
	11000	5008P	24.5	\$84,866	EV-4	5008P	24.5	\$97,596	EVE-4	\$1,955	---	8VM
150	11000	449VP	24.5	\$82,873	JV-4	449VP	24.5	\$95,303	JVE-4	\$2,185	N/A	8VM
	11000	5008P	24.5	\$93,592	EV-4	5008P	24.5	\$107,631	EVE-4	\$2,185	---	8VM
200	12300	5807P	30.5	\$103,540	JV-4	5807P	30.5	\$119,070	JVE-4	\$2,230	\$13,469	8VM
250	12300	5807P	30.5	\$115,852	JV-4	5807P	30.5	\$133,228	JVE-4	\$2,390	\$13,469	8VM
300	12300	5807P	30.5	\$131,984	JV-4	5807P	30.5	\$151,782	JVE-4	\$2,721	\$13,469	8VM
350	12300	5809P	30.5	\$149,427	JV-4	5809P	30.5	\$171,840	JVE-4	\$3,852	\$19,484	8VM
400	12300	5809P	30.5	\$170,775	JV-4	5809P	30.5	\$196,392	JVE-4	\$4,385	\$19,484	8VM
450	12300	5811P	30.5	\$197,972	JV-4	5811P	30.5	\$227,669	JVE-4	\$5,117	\$22,007	8VM
500	12300	5811P	30.5	\$219,967	JV-4	5811P	30.5	\$252,962	JVE-4	\$5,688	\$22,007	8VM
600	11700	5812P	30.5	\$239,040	JV-4	5812P	30.5	\$272,898	JVE-4	\$6,620	N/A	8VM
700	15000	6812VPA	36	\$257,718	JV-4	6812VPA	36	\$296,376	JVE-4	\$7,704	N/A	9VM
800	15000	6812VPA	36	\$276,634	JV-4	6812VPA	36	\$318,130	JVE-4	\$8,937	N/A	9VM
900	15000	6812VPA	36	\$292,064	JV-4	6812VPA	36	\$335,874	JVE-4	\$9,301	N/A	9VM
1000	15000	6812VPA	36	\$307,897	JV-4	6812VPA	36	\$354,082	JVE-4	\$10,417	N/A	9VM

4160 Volt

HP	Down Thrust (lbs) (#)	Standard Efficient				Premium Efficient				NRR List Adder	Adder C.L.1 Grp. D. Haz.Loc.	Disc. Sym
		Frame	BD (in)	List	Type	Frame	BD(in)	List	Type			
150	11000	449VP	24.5	\$98,617	JV-4	449VP	24.5	\$113,411	JVE-4	\$2,185	N/A	8VM
	11000	5008P	24.5	\$112,232	EV-4	5008P	24.5	\$129,068	EVE-4	\$2,185	---	8VM
200	12300	5807P	30.5	\$123,214	JV-4	5807P	30.5	\$141,695	JVE-4	\$2,230	\$13,469	8VM
250	12300	5807P	30.5	\$135,329	JV-4	5807P	30.5	\$155,629	JVE-4	\$2,390	\$13,469	8VM
300	12300	5809P	30.5	\$152,310	JV-4	5809P	30.5	\$175,157	JVE-4	\$2,721	\$19,484	8VM
350	12300	5809P	30.5	\$172,455	JV-4	5809P	30.5	\$198,324	JVE-4	\$3,852	\$19,484	8VM
400	12300	5811P	30.5	\$197,089	JV-4	5811P	30.5	\$226,653	JVE-4	\$4,385	\$22,007	8VM
450	12300	5811P	30.5	\$221,728	JV-4	5811P	30.5	\$254,986	JVE-4	\$5,117	\$22,007	8VM
500	11700	5812P	30.5	\$246,362	JV-4	5812P	30.5	\$283,317	JVE-4	\$5,688	N/A	8VM
600	11700	5812P	30.5	\$250,992	JV-4	5812P	30.5	\$288,661	JVE-4	\$6,620	N/A	8VM
700	15000	6812VPA	36	\$270,604	JV-4	6812VPA	36	\$320,488	JVE-4	\$7,704	N/A	9VM
800	15000	6812VPA	36	\$288,005	JV-4	6812VPA	36	\$341,097	JVE-4	\$8,937	N/A	9VM
900	15000	6812VPA	36	\$305,303	JV-4	6812VPA	36	\$351,098	JVE-4	\$9,301	N/A	9VM
1000	15000	6812VPA	36	\$320,552	JV-4	6812VPA	36	\$368,635	JVE-4	\$10,417	N/A	9VM

Momentary Upthrust Capacity is 30% of Standard High Thrust Design
 • NRR = Non-Reverse Ratchet

See Page M-84 For Available And Alternate BD Dimensions



† All marks shown within this document are properties of their respective owners.

Three Phase Modifiable Motors
Vertical Solid Shaft
High Thrust - "P" Base
Totally Enclosed Fan Cooled (TEFC)
10 Pole, 720 RPM



APPLICATIONS:

For use on Turbine, Mix Flow and Propeller Pumps

FEATURES:

- * Class F Insulation, Class B Rise at Full Load (Sine Wave Power)
- * 1.00 Service Factor (Sine Wave Power)
- * Maximum 40 Deg. C. Ambient, 3,300 Feet Altitude
- * NEMA Design "B"
- * 3 Phase 60 Hz

200, 230/460, 575 Volts (&)

HP	Down Thrust (lbs)(#)	Standard Efficient			Premium Efficient			NRR List Adder	Adder C.L.1 Grp. D. Haz. Loc.	Disc. Sym
		Frame	List	Type	Frame	List	Type			
1.5	3400	213VP	\$2,926	TV-4	213VP	\$3,658	TVS-4	\$326	\$822	7VHTM
2	3400	215VP	\$3,447	TV-4	215VP	\$4,308	TVS-4	\$385	\$822	7VHTM
3	4500	254VP	\$5,116	TV-4	254VP	\$6,395	TVS-4	\$570	\$1,502	7VHTM
5	4500	256VP	\$6,319	TV-4	256VP	\$7,899	TVS-4	\$702	\$1,502	7VHTM
7.5	4500	284VP	\$7,159	TV-4	284VP	\$8,949	TVS-4	\$810	\$2,347	7VHTM
10	4500	286VP	\$8,046	TV-4	286VP	\$10,058	TVS-4	\$894	\$2,347	7VHTM
15	6000	324VP	\$9,894	TV-4	324VP	\$12,368	TVS-4	\$1,026	\$3,192	7VHTM
20	7600	364VP	\$11,716	TV-4	364VP	\$14,645	TVS-4	\$1,202	\$4,225	7VHTM
25	7600	365VP	\$13,319	TV-4	365VP	\$16,648	TVS-4	\$1,385	\$4,225	7VHTM
30	9500	404VP	\$16,195	TV-4	404VP	\$20,244	TVS-4	\$1,526	\$4,930	7VHTM
40	9500	405VP	\$19,379	TV-4	405VP	\$24,224	TVS-4	\$1,631	\$4,930	7VHTM
50	12600	444VP	\$23,202	TV-4	444VP	\$29,003	TVS-4	\$1,854	\$6,103	7VHTM
60	12600	447VP	\$26,683	TV-4	447VP	\$33,354	TVS-4	\$1,869	\$7,042	7VHTM
75	12600	447VP	\$32,405	TV-4	447VP	\$40,506	TVS-4	\$1,995	\$7,042	7VHTM
100	11900	449VP	\$62,211	JV-4	449VP	\$71,542	JVE-4	\$1,887	N/A	9VM
	11900	5008P	\$73,178	EV-4	5008P	\$84,155	EVE-4	\$1,887	---	9VM
125	11900	449VP	\$65,129	JV-4	449VP	\$74,899	JVE-4	\$2,014	N/A	9VM
	11900	5008P	\$79,385	EV-4	5008P	\$91,293	EVE-4	\$2,014	---	9VM
150	11900	449VP	\$86,559	JV-4	449VP	\$99,542	JVE-4	\$2,674	N/A	9VM
	11900	5008P	\$99,777	EV-4	5008P	\$114,474	EVE-4	\$2,674	---	9VM
200	13100	5807P	\$117,650	JV-4	5807P	\$135,298	JVE-4	\$3,718	\$13,469	9VM
250	13100	5809P	\$133,298	JV-4	5809P	\$153,293	JVE-4	\$4,385	\$13,469	9VM
300	13100	5809P	\$143,556	JV-4	5809P	\$165,089	JVE-4	\$5,261	\$13,469	9VM
350	13100	5811P	\$164,624	JV-4	5811P	\$189,319	JVE-4	\$5,589	\$19,484	9VM
400	13100	5811P	\$189,561	JV-4	5811P	\$217,995	JVE-4	\$5,918	\$19,484	9VM
500	12600	5812P	\$201,056	JV-4	5812P	\$231,214	JVE-4	\$6,388	N/A	9VM
600	16300	6812VPA	\$227,193	JV-4	6812VPA	\$261,272	JVE-4	\$7,730	N/A	9VM
700	16300	6812VPA	\$256,728	JV-4	6812VPA	\$295,237	JVE-4	\$8,344	N/A	9VM

Momentary Upthrust Capacity is 30% of Standard High Thrust Design
 & Standard Voltages Thru 405 Frame; 444 Frame & Larger, Single Voltage 460 or 575 Standard
 • NRR = Non-Reverse Ratchet

See Page M-84 For Available And Alternate BD Dimensions



Three Phase Modifiable Motors
Vertical Solid Shaft
High Thrust - "P" Base
Totally Enclosed Fan Cooled (TEFC)
10 Pole, 720 RPM



APPLICATIONS:

For use on Turbine, Mix Flow and Propeller Pumps

FEATURES:

- * Class F Insulation, Class B Rise at Full Load (Sine Wave Power)
- * 1.00 Service Factor (Sine Wave Power)
- * Maximum 40 Deg. C. Ambient, 3,300 Feet Altitude
- * NEMA Design "B"
- * 3 Phase 60 Hz

2300 Volt

HP	Down Thrust (lbs) (#)	Standard Efficient				Premium Efficient				NRR List Adder	Adder C.L.1 Grp. D. Haz. Loc.	Disc. Sym
		Frame	BD (in)	List	Type	Frame	BD(in)	List	Type			
150	13100	5807P	30.5	\$124,810	JV-4	5807P	30.5	\$143,532	JVE-4	\$2,390	\$13,469	9VM
200	13100	5809P	30.5	\$140,005	JV-4	5809P	30.5	\$161,006	JVE-4	\$2,721	\$19,484	9VM
250	13100	5809P	30.5	\$157,958	JV-4	5809P	30.5	\$181,652	JVE-4	\$3,852	\$19,484	9VM
300	13100	5811P	30.5	\$169,941	JV-4	5811P	30.5	\$195,432	JVE-4	\$4,385	\$22,007	9VM
350	13100	5811P	30.5	\$195,080	JV-4	5811P	30.5	\$224,342	JVE-4	\$5,117	\$22,007	9VM
400	12600	5812P	30.5	\$221,784	JV-4	5812P	30.5	\$255,052	JVE-4	\$5,688	N/A	9VM
450	12600	5812P	30.5	\$257,364	JV-4	5812P	30.5	\$295,968	JVE-4	\$6,620	N/A	9VM
500	12600	5812P	30.5	\$285,957	JV-4	5812P	30.5	\$328,851	JVE-4	\$7,613	N/A	9VM
600	12600	5812P	30.5	\$310,752	JV-4	5812P	30.5	\$357,365	JVE-4	\$8,755	N/A	9VM
700	16300	6812PA	36	\$335,033	JV-4	6812PA	36	\$385,288	JVE-4	\$10,068	N/A	9VM
800	16300	6812PA	36	\$359,625	JV-4	6812PA	36	\$413,569	JVE-4	\$11,578	N/A	9VM

4160 Volt

HP	Down Thrust (lbs) (#)	Standard Efficient				Premium Efficient				NRR List Adder	Adder C.L.1 Grp. D. Haz. Loc.	Disc. Sym
		Frame	BD (in)	List	Type	Frame	BD(in)	List	Type			
150	13100	5807P	30.5	\$133,133	JV-4	5807P	30.5	\$153,103	JVE-4	\$2,390	\$13,469	9VM
200	13100	5809P	30.5	\$166,606	JV-4	5809P	30.5	\$191,597	JVE-4	\$2,721	\$19,484	9VM
250	13100	5809P	30.5	\$187,970	JV-4	5809P	30.5	\$216,166	JVE-4	\$3,852	\$19,484	9VM
300	13100	5811P	30.5	\$202,230	JV-4	5811P	30.5	\$232,565	JVE-4	\$4,385	\$22,007	9VM
350	13100	5811P	30.5	\$232,145	JV-4	5811P	30.5	\$266,967	JVE-4	\$5,117	\$22,007	9VM
400	12600	5812P	30.5	\$263,923	JV-4	5812P	30.5	\$303,511	JVE-4	\$5,688	N/A	9VM
450	12600	5812P	30.5	\$306,263	JV-4	5812P	30.5	\$352,203	JVE-4	\$6,620	N/A	9VM
500	12600	5812P	30.5	\$340,289	JV-4	5812P	30.5	\$391,332	JVE-4	\$7,613	N/A	9VM
600	12600	5812P	30.5	\$369,795	JV-4	5812P	30.5	\$425,264	JVE-4	\$8,755	N/A	9VM
700	16300	6812PA	36	\$398,690	JV-4	6812PA	36	\$458,494	JVE-4	\$10,068	N/A	9VM
800	16300	6812PA	36	\$427,954	JV-4	6812PA	36	\$492,147	JVE-4	\$11,578	N/A	9VM

Momentary Upthrust Capacity is 30% of Standard High Thrust Design

• NRR = Non-Reverse Ratchet

See Page M-84 For Available And Alternate BD Dimensions



† All marks shown within this document are properties of their respective owners.

Three Phase Modifiable Motors
Vertical Solid Shaft SNOWMASTER™
High Thrust - “P” Base
Weather Protected Type I (WPI)
2 Pole, 3600 RPM



APPLICATIONS:

For use on Snow Making Equipment

FEATURES:

- * Premium Efficient, Class H Inverter Grade® Insulation
- * Class B Rise at Full Load (Sine Wave Power)
- * 1.15 Service Factor (Sine Wave Power)
- * Maximum 40 Deg. C. Ambient, 10,000 Feet Altitude
- * NEMA Design “B”
- * 3 Phase 60 Hz
- * INSULIFE™ 2000 on 400-440 & VPI Epoxy on 5000
- * Continuous Up and Down Thrust Protection
- * Special Balance (0.10 IPS-Peak)
- * Shaft Ground Ring
- * Insulated Upper Thrust Bearing
- * Normally Closed Thermostats (1 per phase)
- * 115 Volt Space Heater
- * Separate Accessory Outlet Box

460 Volts

HP	Down Thrust (lbs)(#)	Frame	BD (in)	List	Type	Disc. Sym
125	5200	404VP	16.5	\$17,461	RVI-4	7VHTM
150	5200	405VP	16.5	\$24,037	RVI-4	7VHTM
200	7000	444VP	16.5	\$31,561	RVI-4	7VHTM
250	7000	445VPA	20	\$37,257	RVI-4	7VHTM
300	7000	5008PH	20	\$61,212	RVEI-4	8VM
350	7000	5008PH	20	\$79,621	RVEI-4	8VM
400	7000	5008PH	20	\$95,157	RVEI-4	8VM
450	7000	5008PH	20	\$99,172	RVEI-4	8VM
500	7000	5008PH	20	\$103,171	RVEI-4	8VM
600	7000	5012PH	20	\$123,807	RVEI-4	8VM

Momentary Upthrust Capacity is 30% of Standard High Thrust Design

See Page M-83 For Available And Alternate BD Dimensions



Three Phase Modifiable Motors
Vertical Solid Shaft SNOWMASTER™
High Thrust - “P” Base
Weather Protected Type I (WPI)
2 Pole, 3600 RPM



APPLICATIONS:

For use on Snow Making Equipment

FEATURES:

- * Premium Efficient, Class H Inverter Grade® Insulation
- * Class B Rise at Full Load (Sine Wave Power)
- * 1.15 Service Factor (Sine Wave Power)
- * Maximum 40 Deg. C. Ambient, 10,000 Feet Altitude
- * NEMA Design “B”
- * 3 Phase 60 Hz
- * INSULIFE™ 5000 (VPI Epoxy)
- * Continuous Up and Down Thrust Protection
- * Special Balance (0.10 IPS-Peak)
- * Shaft Ground Ring
- * Insulated Upper Thrust Bearing
- * Normally Closed Thermostats (1 per phase)
- * 115 Volt Space Heater
- * Separate Accessory Outlet Box

2300 Volts

HP	Down Thrust (lbs)(#)	Frame	BD (in)	List	Type	Disc. Sym
150	7000	5008PH	20	\$53,363	RVEI-4	8VM
200	7000	5008PH	20	\$55,037	RVEI-4	8VM
250	7000	5008PH	20	\$65,717	RVEI-4	8VM
300	7000	5008PH	20	\$75,284	RVEI-4	8VM
350	7000	5008PH	20	\$84,851	RVEI-4	8VM
400	7000	5012PH	20	\$93,999	RVEI-4	8VM
450	7000	5012PH	20	\$103,986	RVEI-4	8VM
500	7000	5012P	24.5	\$113,551	RVEI-4	8VM
600	7000	5012P	24.5	\$140,822	RVEI-4	8VM

Momentary Upthrust Capacity is 30% of Standard High Thrust Design

4000 Volts

HP	Down Thrust (lbs)(#)	Frame	BD (in)	List	Type	Disc. Sym
150	7000	5008PH	20	\$60,727	RVEI-4	8VM
200	7000	5008PH	20	\$62,631	RVEI-4	8VM
250	7000	5008PH	20	\$74,795	RVEI-4	8VM
300	7000	5008PH	20	\$85,678	RVEI-4	8VM
350	7000	5008PH	20	\$96,563	RVEI-4	8VM
400	7000	5012PH	20	\$106,971	RVEI-4	8VM
450	7000	5012PH	20	\$118,333	RVEI-4	8VM
500	7000	5012P	24.5	\$129,220	RVEI-4	8VM
600	7000	5012P	24.5	\$158,569	RVEI-4	8VM

Momentary Upthrust Capacity is 30% of Standard High Thrust Design

See Page M-83 For Available And Alternate BD Dimensions



Three Phase Modifiable Motors
Vertical Solid Shaft
Corro-Duty Medium Thrust, In-Line
Totally Enclosed Fan Cooled (TEFC)
2 Pole, 3600 RPM



APPLICATIONS:

For use on Booster Pumps

FEATURES:

- * Class F Insulation, Class B Rise at Full Load (Sine Wave Power)
- * 1.00 Service Factor (Sine Wave Power)
- * Maximum 40 Deg. C. Ambient, 3,300 Feet Altitude
- * 3 Phase 60 Hz
- * NEMA Design "B"
- * CORRO-DUTY
- * Continuous Up and Down Thrust Protection

230/460, 575 Volts

HP	Down Thrust (lbs)(#)	Energy Efficient			Premium Efficient			Disc. Sym
		Frame	List	Type	Frame	List	Type	
3	790	182LP	\$2,054	TVCE-9	182LP	\$2,156	TVCS-9	7IN
5	790	184LP	\$2,353	TVCE-9	184LP	\$2,471	TVCS-9	7IN
7.5	1205	213LP	\$2,579	TVCE-9	213LP	\$2,703	TVCS-9	7IN
10	1205	215LP	\$2,875	TVCE-9	215LP	\$3,012	TVCS-9	7IN
15	1460	254LP	\$3,653	TVCE-9	254LP	\$3,828	TVCS-9	7IN
20	1460	256LP	\$4,291	TVCE-9	256LP	\$4,496	TVCS-9	7IN
25	1465	284LP	\$5,353	TVCE-9	284LP	\$5,610	TVCS-9	7IN
30	1465	286LP	\$6,055	TVCE-9	286LP	\$6,345	TVCS-9	7IN
40	1040	324LP	\$9,004	TVCE-9	324LP	\$9,413	TVCS-9	7IN
50	1080	326LP	\$10,385	TVCE-9	326LP	\$10,857	TVCS-9	7IN
60	1130	364LP	\$12,723	TVCE-9	364LP	\$13,300	TVCS-9	7IN
75	1190	365LP	\$15,893	TVCE-9	365LP	\$16,616	TVCS-9	7IN
100	1230	405LP	\$22,883	TVCE-9	405LP	\$23,923	TVCS-9	7IN
125	1310	444LP	\$27,350	TVCE-9	444LP	\$28,594	TVCS-9	7IN
150	1350	447LP	\$33,240	TVCE-9	447LP	\$34,752	TVCS-9	7IN

Rated 2 Years, 17500 Hours L-10 Life

• Standard Voltages Thru 405 Frame; 444 Frame & Larger, Single Voltage 460 or 575 is Standard

See Page M-84 For Available And Alternate BD Dimensions

* 60Hz 3600, 1800, 1200 & 900 RPM motors comply with U.S. D.O.E.'s Efficiency regulation 10 CFR Section 431 Subpart B – electric motors (See Page M-80 - M-81 for Nominal Efficiency Table)



Three Phase Modifiable Motors
Vertical Solid Shaft
Corro-Duty Medium Thrust, In-Line
Totally Enclosed Fan Cooled (TEFC)
4 Pole, 1800 RPM



APPLICATIONS:

For use on Booster Pumps

FEATURES:

- * Class F Insulation, Class B Rise at Full Load (Sine Wave Power)
- * 1.00 Service Factor (Sine Wave Power)
- * Maximum 40 Deg. C. Ambient, 3,300 Feet Altitude
- * 3 Phase 60 Hz
- * NEMA Design "B"
- * CORRO-DUTY
- * Continuous Up and Down Thrust Protection

230/460, 575 Volts

HP	Down Thrust (lbs)(#)	Energy Efficient			Premium Efficient			Disc. Sym
		Frame	List	Type	Frame	List	Type	
3	1015	182LP	\$1,917	TVCE-9	182LP	\$2,014	TVCS-9	7IN
5	1015	184LP	\$2,086	TVCE-9	184LP	\$2,190	TVCS-9	7IN
7.5	1410	213LP	\$2,413	TVCE-9	213LP	\$2,529	TVCS-9	7IN
10	1410	215LP	\$2,739	TVCE-9	215LP	\$2,870	TVCS-9	7IN
15	1860	254LP	\$3,383	TVCE-9	254LP	\$3,545	TVCS-9	7IN
20	1860	256LP	\$3,943	TVCE-9	256LP	\$4,132	TVCS-9	7IN
25	1860	284LP	\$4,849	TVCE-9	284LP	\$5,081	TVCS-9	7IN
30	1860	286LP	\$5,441	TVCE-9	286LP	\$5,700	TVCS-9	7IN
40	1325	324LP	\$8,397	TVCE-9	324LP	\$8,779	TVCS-9	7IN
50	1400	326LP	\$9,965	TVCE-9	326LP	\$10,418	TVCS-9	7IN
60	1450	364LP	\$11,818	TVCE-9	364LP	\$12,356	TVCS-9	7IN
75	1500	365LP	\$14,390	TVCE-9	365LP	\$15,045	TVCS-9	7IN
100	1550	405LP	\$19,392	TVCE-9	405LP	\$20,275	TVCS-9	7IN
125	1650	444LP	\$25,049	TVCE-9	444LP	\$26,188	TVCS-9	7IN
150	1700	447LP	\$30,599	TVCE-9	447LP	\$31,991	TVCS-9	7IN
200	1700	447LP	\$42,760	TVCE-9	447LP	\$44,704	TVCS-9	7IN

Rated 2 Years, 17500 Hours L-10 Life
 & Standard Voltages Thru 405 Frame; 444 Frame & Larger, Single Voltage 460 or 575 is Standard

See Page M-84 For Available And Alternate BD Dimensions

* 60Hz 3600, 1800, 1200 & 900 RPM motors comply with U.S. D.O.E.'s Efficiency regulation 10 CFR Section 431 Subpart B – electric motors (See Page M-80 - M-81 for Nominal Efficiency Table)



Three Phase Modifiable Motors
Vertical Solid Shaft
Corro-Duty Medium Thrust, In-Line
Totally Enclosed Fan Cooled (TEFC)
6 Pole, 1200 RPM



APPLICATIONS:

For use on Booster Pumps

FEATURES:

- * Class F Insulation, Class B Rise at Full Load (Sine Wave Power)
- * 1.00 Service Factor (Sine Wave Power)
- * Maximum 40 Deg. C. Ambient, 3,300 Feet Altitude
- * 3 Phase 60 Hz
- * NEMA Design "B"
- * CORRO-DUTY
- * Continuous Up and Down Thrust Protection

230/460, 575 Volts (&)

HP	Down Thrust (lbs)(#)	Energy Efficient			Premium Efficient			Disc. Sym
		Frame	List	Type	Frame	List	Type	
3	1635	213LP	\$2,351	TVCE-9	213LP	\$2,464	TVCS-9	7IN
5	1635	215LP	\$3,003	TVCE-9	215LP	\$3,147	TVCS-9	7IN
7.5	2140	254LP	\$3,926	TVCE-9	254LP	\$4,114	TVCS-9	7IN
10	2140	256LP	\$4,525	TVCE-9	256LP	\$4,741	TVCS-9	7IN
15	2140	284LP	\$5,750	TVCE-9	284LP	\$6,026	TVCS-9	7IN
20	2140	286LP	\$6,693	TVCE-9	286LP	\$7,012	TVCS-9	7IN
25	1375	324LP	\$9,389	TVCE-9	324LP	\$9,816	TVCS-9	7IN
30	1430	326LP	\$10,716	TVCE-9	326LP	\$11,204	TVCS-9	7IN
40	1520	364LP	\$13,445	TVCE-9	364LP	\$14,055	TVCS-9	7IN
50	1600	365LP	\$15,857	TVCE-9	365LP	\$16,578	TVCS-9	7IN
60	1660	404LP	\$19,315	TVCE-9	404LP	\$20,193	TVCS-9	7IN
75	1720	405LP	\$22,718	TVCE-9	405LP	\$23,748	TVCS-9	7IN
100	1750	444LP	\$30,622	TVCE-9	444LP	\$32,701	TVCS-9	7IN
125	1780	447LP	\$37,018	TVCE-9	447LP	\$38,701	TVCS-9	7IN
150	1780	447LP	\$45,999	TVCE-9	447LP	\$48,090	TVCS-9	7IN

Rated 2 Years, 17500 Hours L-10 Life
 & Standard Voltages Thru 405 Frame; 444 Frame & Larger, Single Voltage 460 or 575 is Standard

See Page M-84 For Available And Alternate BD Dimensions

* 60Hz 3600, 1800, 1200 & 900 RPM motors comply with U.S. D.O.E.'s Efficiency regulation 10 CFR Section 431 Subpart B – electric motors (See Page M-80 - M-81 for Nominal Efficiency Table)



Three Phase Modifiable Motors
Vertical Solid Shaft / Meets IEEE Std 841™-2021
Medium Thrust - “P” Base
Totally Enclosed Fan Cooled (TEFC)
200, 230/460, 575 Volts (&)



APPLICATIONS:

For use on Booster Pumps

FEATURES:

- * Corro-Duty Construction
- * Class F Insulation, Class B Rise at Full Load (Sine Wave Power)
- * 1.15 Service Factor (Sine Wave Power)
- * Maximum 40 Deg. C. Ambient, 3,300 Feet Altitude
- * INPRO/SEAL^{®†} on both ends
- * Special balance
- * Special shaft runout
- * NEMA Design “B”
- * 3 Phase 60 Hz
- * Non-witnessed IEEE 841 Enhanced no load test
- * Grounding in terminal box and frame
- * Oversized main conduit box

3600 RPM

HP	Down Thrust (lbs)(#)	Down Thrust (lbs)(+)	Premium Efficient			Disc. Sym
			Frame	List	Type	
3	790	630	182LP	\$2,479	CEV-9	7IN
5	790	630	184LP	\$2,842	CEV-9	7IN
7.5	1205	885	213LP	\$3,108	CEV-9	7IN
10	1205	885	215LP	\$3,464	CEV-9	7IN
15	1460	1080	254LP	\$4,401	CEV-9	7IN
20	1460	1080	256LP	\$5,169	CEV-9	7IN
25	1465	1330	284LP	\$6,450	CEV-9	7IN
30	1465	1330	286LP	\$7,297	CEV-9	7IN

1800 RPM

HP	Down Thrust (lbs)(#)	Down Thrust (lbs)(+)	Premium Efficient			Disc. Sym
			Frame	List	Type	
3	1015	795	182LP	\$2,316	CEV-9	7IN
5	1015	795	184LP	\$2,519	CEV-9	7IN
7.5	1410	1120	213LP	\$2,908	CEV-9	7IN
10	1410	1120	215LP	\$3,301	CEV-9	7IN
15	1860	1365	254LP	\$4,077	CEV-9	7IN
20	1860	1365	256LP	\$4,752	CEV-9	7IN
25	1860	1680	284LP	\$5,842	CEV-9	7IN
30	1860	1680	286LP	\$6,555	CEV-9	7IN

*Alternate “Z” Option Available for Shaft. See Dimension Pages for Details

Rated 2 Years, 17500 Hours L-10 Life

& Standard Voltages

+Minimum downthrust for 50,000 hours L-10 bearing life

See Page M-84 For Available And Alternate BD Dimensions

* 60Hz 3600, 1800, 1200 & 900 RPM motors comply with U.S. D.O.E.’s Efficiency regulation 10 CFR Section 431 Subpart B – electric motors (See Page M-80 - M-81 for Nominal Efficiency Table)



Three Phase Modifiable Motors
Vertical Solid Shaft / Meets IEEE Std 841™-2021
Medium Thrust - “P” Base
Totally Enclosed Fan Cooled (TEFC)
200, 230/460, 575 Volts (&)



APPLICATIONS:

For use on Booster Pumps

FEATURES:

- * Corro-Duty Construction
- * Class F Insulation, Class B Rise at Full Load (Sine Wave Power)
- * 1.15 Service Factor (Sine Wave Power)
- * Maximum 40 Deg. C. Ambient, 3,300 Feet Altitude
- * INPRO/SEAL®† on both ends
- * Special balance
- * Special shaft runout
- * NEMA Design “B”
- * 3 Phase 60 Hz
- * Non-witnessed IEEE 841 Enhanced no load test
- * Grounding in terminal box and frame
- * Oversized main conduit box

1200 RPM

HP	Down Thrust (lbs)(#)	Down Thrust (lbs)(+)	Premium Efficient			Disc. Sym
			Frame	List	Type	
3	1635	1280	213LP	\$2,834	CEV-9	7IN
5	1635	1280	215LP	\$3,618	CEV-9	7IN
7.5	2140	1565	254LP	\$4,731	CEV-9	7IN
10	2140	1565	256LP	\$5,461	CEV-9	7IN
15	2140	1920	284LP*	\$6,929	CEV-9	7IN
20	2140	1920	286LP*	\$8,064	CEV-9	7IN

*Alternate “Z” Option Available for Shaft. See Dimension Pages for Details

Rated 2 Years, 17500 Hours L-10 Life

& Standard Voltages

+Minimum downthrust for 50,000 hours L-10 bearing life

See Page M-84 For Available And Alternate BD Dimensions

* 60Hz 3600, 1800, 1200 & 900 RPM motors comply with U.S. D.O.E.’s Efficiency regulation 10 CFR Section 431 Subpart B – electric motors (See Page M-80 - M-81 for Nominal Efficiency Table)



Three Phase Modifiable Motors
Vertical Solid Shaft
Medium-High Thrust,
Totally Enclosed Fan Cooled (TEFC)
2 Pole, 3600 RPM



APPLICATIONS:

For use on Turbine, Mix Flow and Propeller Pumps

FEATURES:

- * Class F Insulation, Class B Rise at Full Load (Sine Wave Power)
- * 1.00 Service Factor (Sine Wave Power)
- * Maximum 40 Deg. C. Ambient, 3,300 Feet Altitude
- * NEMA Design "B"
- * 3 Phase 60 Hz
- * Cast Iron Frame and Fan Cover Guard

230/460, 575 Volts

HP	Down Thrust (lbs)(#)	Energy Efficient			Premium Efficient			Disc. Sym
		Frame	List	Type	Frame	List	Type	
3	1000	182VP	\$1,938	CTVE-3	182VP	\$2,040	CTVS-3	7IN
5	1000	184VP	\$2,220	CTVE-3	184VP	\$2,338	CTVS-3	7IN
7.5	1570	213VP	\$2,433	CTVE-3	213VP	\$2,557	CTVS-3	7IN
10	1570	215VP	\$2,712	CTVE-3	215VP	\$2,849	CTVS-3	7IN
15	1860	254VP	\$3,446	CTVE-3	254VP	\$3,621	CTVS-3	7IN
20	1860	256VP	\$4,048	CTVE-3	256VP	\$4,253	CTVS-3	7IN
25	1860	284VP	\$5,049	CTVE-3	284VP	\$5,307	CTVS-3	7IN
30	1860	286VP	\$5,712	CTVE-3	286VP	\$6,002	CTVS-3	7IN

Momentary Upthrust Capacity is 30% of Standard High Thrust Design
 • Standard Voltages Thru 286 Frame

Non-Reverse Ratchet is not available on Medium-High Thrust

See Page M-84 For Available And Alternate BD Dimensions

* 60Hz 3600, 1800, 1200 & 900 RPM motors comply with U.S. D.O.E.'s Efficiency regulation 10 CFR Section 431 Subpart B – electric motors (See Page M-80 - M-81 for Nominal Efficiency Table)



Three Phase Modifiable Motors
Vertical Solid Shaft
Medium-High Thrust,
Totally Enclosed Fan Cooled (TEFC)
4 Pole, 1800 RPM



APPLICATIONS:

For use on Turbine, Mix Flow and Propeller Pumps

FEATURES:

- * Class F Insulation, Class B Rise at Full Load (Sine Wave Power)
- * 1.00 Service Factor (Sine Wave Power)
- * Maximum 40 Deg. C. Ambient, 3,300 Feet Altitude
- * NEMA Design "B"
- * 3 Phase 60 Hz
- * Cast Iron Frame and Fan Cover Guard

230/460, 575 Volts

HP	Down Thrust (lbs)(#)	Energy Efficient			Premium Efficient			Disc. Sym
		Frame	List	Type	Frame	List	Type	
3	1285	182VP	\$1,808	CTVE-3	182VP	\$1,905	CTVS-3	7IN
5	1285	184VP	\$1,968	CTVE-3	184VP	\$2,072	CTVS-3	7IN
7.5	1785	213VP	\$2,276	CTVE-3	213VP	\$2,392	CTVS-3	7IN
10	1785	215VP	\$2,584	CTVE-3	215VP	\$2,715	CTVS-3	7IN
15	2355	254VP	\$3,192	CTVE-3	254VP	\$3,354	CTVS-3	7IN
20	2355	256VP	\$3,720	CTVE-3	256VP	\$3,909	CTVS-3	7IN
25	2355	284VP	\$4,575	CTVE-3	284VP	\$4,807	CTVS-3	7IN
30	2355	286VP	\$5,133	CTVE-3	286VP	\$5,392	CTVS-3	7IN

Momentary Upthrust Capacity is 30% of Standard High Thrust Design
 • Standard Voltages Thru 286 Frame

Non-Reverse Ratchet is not available on Medium-High Thrust

See Page M-84 For Available And Alternate BD Dimensions

* 60Hz 3600, 1800, 1200 & 900 RPM motors comply with U.S. D.O.E.'s Efficiency regulation 10 CFR Section 431 Subpart B – electric motors (See Page M-80 - M-81 for Nominal Efficiency Table)



**Three Phase Modifiable Motors
Vertical Solid Shaft
Medium-High Thrust,
Totally Enclosed Fan Cooled (TEFC)
6 Pole, 1200 RPM**



APPLICATIONS:

For use on Turbine, Mix Flow and Propeller Pumps

FEATURES:

- * Class F Insulation, Class B Rise at Full Load (Sine Wave Power)
- * 1.00 Service Factor (Sine Wave Power)
- * Maximum 40 Deg. C. Ambient, 3,300 Feet Altitude
- * NEMA Design "B"
- * 3 Phase 60 Hz
- * Cast Iron Frame and Fan Cover Guard

230/460, 575 Volts

HP	Down Thrust (lbs)(#)	Energy Efficient			Premium Efficient			Disc. Sym
		Frame	List	Type	Frame	List	Type	
2	1425	184VP	\$2,158	CTVE-3	184VP	\$2,266	CTVS-3	7IN
3	2070	213VP	\$2,218	CTVE-3	213VP	\$2,331	CTVS-3	7IN
5	2070	215VP	\$2,833	CTVE-3	215VP	\$2,977	CTVS-3	7IN
7.5	2710	254VP	\$3,074	CTVE-3	254VP	\$3,892	CTVS-3	7IN
10	2710	256VP	\$4,269	CTVE-3	256VP	\$4,485	CTVS-3	7IN
15	2710	284VP	\$5,425	CTVE-3	284VP	\$5,701	CTVS-3	7IN
20	2710	286VP	\$6,314	CTVE-3	286VP	\$6,633	CTVS-3	7IN

Momentary Upthrust Capacity is 30% of Standard High Thrust Design
• Standard Voltages Thru 286 Frame

Non-Reverse Ratchet is not available on Medium-High Thrust

See Page M-84 For Available And Alternate BD Dimensions

* 60Hz 3600, 1800, 1200 & 900 RPM motors comply with U.S. D.O.E.'s Efficiency regulation 10 CFR Section 431 Subpart B – electric motors (See Page M-80 - M-81 for Nominal Efficiency Table)



Three Phase Modifiable Motors
Vertical Solid Shaft
Medium-High Thrust,
Totally Enclosed Fan Cooled (TEFC)
8 Pole, 900 RPM



APPLICATIONS:

For use on Turbine, Mix Flow and Propeller Pumps

FEATURES:

- * Class F Insulation, Class B Rise at Full Load (Sine Wave Power)
- * 1.00 Service Factor (Sine Wave Power)
- * Maximum 40 Deg. C. Ambient, 3,300 Feet Altitude
- * NEMA Design "B"
- * 3 Phase 60 Hz
- * Cast Iron Frame and Fan Cover Guard

230/460, 575 Volts

HP	Down Thrust (lbs)(#)	Energy Efficient			Premium Efficient			Disc. Sym
		Frame	List	Type	Frame	List	Type	
1.5	1425	184VP	\$2,519	CTVE-3	184VP	\$2,645	CTVS-3	7IN
2	2285	213VP	\$2,575	CTVE-3	213VP	\$2,705	CTVS-3	7IN
3	2285	215VP	\$2,999	CTVE-3	215VP	\$3,152	CTVS-3	7IN
5	3000	254VP	\$4,144	CTVE-3	254VP	\$4,353	CTVS-3	7IN
7.5	3000	256VP	\$5,194	CTVE-3	256VP	\$5,458	CTVS-3	7IN
10	3000	284VP	\$6,374	CTVE-3	284VP	\$6,698	CTVS-3	7IN
15	3000	286VP	\$7,456	CTVE-3	286VP	\$7,834	CTVS-3	7IN

Momentary Upthrust Capacity is 30% of Standard High Thrust Design
 • Standard Voltages Thru 286 Frame

Non-Reverse Ratchet is not available on Medium-High Thrust

See Page M-84 For Available And Alternate BD Dimensions

* 60Hz 3600, 1800, 1200 & 900 RPM motors comply with U.S. D.O.E.'s Efficiency regulation 10 CFR Section 431 Subpart B – electric motors (See Page M-80 - M-81 for Nominal Efficiency Table)



Three Phase Modifiable Motors
Vertical Solid Shaft / Meets IEEE Std 841™-2021
Medium-High Thrust - “P” Base
Totally Enclosed Fan Cooled (TEFC)
200, 230/460, 575 Volts (&)



APPLICATIONS:

For use on Turbine, Mix Flow and Propeller Pumps

FEATURES:

- * Corro-Duty Construction
- * Class F Insulation, Class B Rise at Full Load (Sine Wave Power)
- * 1.15 Service Factor (Sine Wave Power)
- * Maximum 40 Deg. C. Ambient, 3,300 Feet Altitude
- * INPRO/SEAL®† on both ends
- * Special balance
- * Special shaft runout
- * NEMA Design “B”
- * 3 Phase 60 Hz
- * Non-witnessed IEEE 841 Enhanced no load test
- * Grounding in terminal box and frame
- * Oversized main conduit box

3600 RPM

HP	Down Thrust (lbs)(#)	Down Thrust (lbs)(+)	Premium Efficient			Disc. Sym
			Frame	List	Type	
3	1000	630	182VP	\$2,479	CEV-3	7IN
5	1000	630	184VP	\$2,842	CEV-3	7IN
7.5	1570	885	213VP	\$3,108	CEV-3	7IN
10	1570	885	215VP	\$3,464	CEV-3	7IN
15	1860	1080	254VP	\$4,401	CEV-3	7IN
20	1860	1080	256VP	\$5,169	CEV-3	7IN
25	1860	1330	284VP	\$6,450	CEV-3	7IN
30	1860	1330	286VP	\$7,297	CEV-3	7IN

1800 RPM

HP	Down Thrust (lbs)(#)	Down Thrust (lbs)(+)	Premium Efficient			Disc. Sym
			Frame	List	Type	
3	1285	795	182VP	\$2,316	CEV-3	7IN
5	1285	795	184VP	\$2,519	CEV-3	7IN
7.5	1785	1120	213VP	\$2,908	CEV-3	7IN
10	1785	1120	215VP	\$3,301	CEV-3	7IN
15	2355	1365	254VP	\$4,077	CEV-3	7IN
20	2355	1365	256VP	\$4,752	CEV-3	7IN
25	2355	1680	284VP	\$5,842	CEV-3	7IN
30	2355	1680	286VP	\$6,555	CEV-3	7IN

- # Rated 1 Years, 8800 Hours L-10 Life
- +Minimum downthrust for 50,000 hours L-10 bearing life
- Momentary Upthrust Capacity is 30% of Standard High Thrust Design
- Standard Voltages Thru 286 Frame

Non-Reverse Ratchet is not available on Medium-High Thrust

See Page M-84 For Available And Alternate BD Dimensions

* 60Hz 3600, 1800, 1200 & 900 RPM motors comply with U.S. D.O.E.’s Efficiency regulation 10 CFR Section 431 Subpart B – electric motors (See Page M-80 - M-81 for Nominal Efficiency Table)



† All marks shown within this document are properties of their respective owners.

Three Phase Modifiable Motors
Vertical Solid Shaft / Meets IEEE Std 841™-2021
Medium-High Thrust - “P” Base
Totally Enclosed Fan Cooled (TEFC)
200, 230/460, 575 Volts (&)



APPLICATIONS:

For use on Turbine, Mix Flow and Propeller Pumps

FEATURES:

- * Corro-Duty Construction
- * Class F Insulation, Class B Rise at Full Load (Sine Wave Power)
- * 1.15 Service Factor (Sine Wave Power)
- * Maximum 40 Deg. C. Ambient, 3,300 Feet Altitude
- * INPRO/SEAL®† on both ends
- * Special balance
- * Special shaft runout
- * NEMA Design “B”
- * 3 Phase 60 Hz
- * Non-witnessed IEEE 841 Enhanced no load test
- * Grounding in terminal box and frame
- * Oversized main conduit box

1200 RPM

HP	Down Thrust (lbs)(#)	Down Thrust (lbs)(+)	Premium Efficient			Disc. Sym
			Frame	List	Type	
3	2070	1280	213VP	\$2,834	CEV-3	7IN
5	2070	1280	215VP	\$3,618	CEV-3	7IN
7.5	2710	1565	254VP	\$4,731	CEV-3	7IN
10	2710	1565	256VP	\$5,461	CEV-3	7IN
15	2710	1920	284VP	\$6,929	CEV-3	7IN
20	2710	1920	286VP	\$8,064	CEV-3	7IN

900 RPM

HP	Down Thrust (lbs)(#)	Down Thrust (lbs)(+)	Premium Efficient			Disc. Sym
			Frame	List	Type	
2	2285	1410	213VP	\$3,289	CEV-3	7IN
3	2285	1410	215VP	\$3,832	CEV-3	7IN
5	3000	1720	254VP	\$5,292	CEV-3	7IN
7.5	3000	1720	256VP	\$6,636	CEV-3	7IN
10	3000	2120	284VP	\$8,142	CEV-3	7IN
15	3000	2120	286VP*	\$9,523	CEV-3	7IN

- # Rated 1 Years, 8800 Hours L-10 Life
- +Minimum downthrust for 50,000 hours L-10 bearing life
- Momentary Upthrust Capacity is 30% of Standard High Thrust Design
- Standard Voltages Thru 286 Frame

Non-Reverse Ratchet is not available on Medium-High Thrust

See Page M-84 For Available And Alternate BD Dimensions

* 60Hz 3600, 1800, 1200 & 900 RPM motors comply with U.S. D.O.E.'s Efficiency regulation 10 CFR Section 431 Subpart B – electric motors (See Page M-80 - M-81 for Nominal Efficiency Table)



Three Phase Modifiable Motors
Vertical Solid Shaft
Medium Thrust, In-Line
Hazardous Location
2 Pole, 3600 RPM



APPLICATIONS:

For use on Booster Pumps

FEATURES:

- * UL Listed Division 1, Class 1, Group D
- * Class F Insulation, Class B Rise at Full Load (Sine Wave Power)
- * 1.00 Service Factor (Sine Wave Power)
- * Maximum 40 Deg. C. Ambient, 3,300 Feet Altitude
- * 3 Phase 60 Hz
- * NEMA Design "B"
- * Continuous Up and Down Thrust Protection

230/460, 575 Volts

HP	Down Thrust (lbs)(#)	Energy Efficient			Premium Efficient			Disc. Sym
		Frame	List	Type	Frame	List	Type	
3	390	182LP	\$3,089	LVE-9	182LP	\$3,216	LVS-9	7IN
5	500	184LP	\$4,174	LVE-9	184LP	\$4,350	LVS-9	7IN
7.5	580	213LP	\$4,723	LVE-9	213LP	\$4,927	LVS-9	7IN
10	640	215LP	\$5,270	LVE-9	215LP	\$5,493	LVS-9	7IN
15	740	254LP	\$5,759	LVE-9	254LP	\$6,005	LVS-9	7IN
20	840	256LP	\$6,903	LVE-9	256LP	\$7,173	LVS-9	7IN
25	900	284LP	\$7,835	LVE-9	284LP	\$8,110	LVS-9	7IN
30	960	286LP	\$8,403	LVE-9	286LP	\$8,706	LVS-9	7IN
40	1040	324LP	\$11,377	LVE-9	324LP	\$11,786	LVS-9	7IN
50	1080	326LP	\$12,633	LVE-9	326LP	\$13,105	LVS-9	7IN
60	1130	364LP	\$15,791	LVE-9	364LP	\$16,368	LVS-9	7IN
75	1190	365LP	\$19,378	LVE-9	365LP	\$20,101	LVS-9	7IN
100	1230	405LP	\$25,733	LVE-9	405LP	\$26,773	LVS-9	7IN
125	1310	444LP	\$30,967	LVE-9	444LP	\$32,211	LVS-9	7IN
150	1350	447LP	\$36,321	LVE-9	447LP	\$37,833	LVS-9	7IN

Rated 2 Years, 17500 Hours L-10 Life
 & Standard Voltages Thru 405 Frame; 444 Frame & Larger, Single Voltage 460 or 575 is Standard

See Page M-84 For Available And Alternate BD Dimensions

* 60Hz 3600, 1800, 1200 & 900 RPM motors comply with U.S. D.O.E.'s Efficiency regulation 10 CFR Section 431 Subpart B – electric motors (See Page M-80 - M-81 for Nominal Efficiency Table)



Three Phase Modifiable Motors
Vertical Solid Shaft
Medium Thrust, In-Line
Hazardous Location
4 Pole, 1800 RPM



APPLICATIONS:

For use on Booster Pumps

FEATURES:

- * UL Listed Division 1, Class 1, Group D
- * Class F Insulation, Class B Rise at Full Load (Sine Wave Power)
- * 1.00 Service Factor (Sine Wave Power)
- * Maximum 40 Deg. C. Ambient, 3,300 Feet Altitude
- * 3 Phase 60 Hz
- * NEMA Design "B"
- * Continuous Up and Down Thrust Protection

230/460, 575 Volts

HP	Down Thrust (lbs)(#)	Energy Efficient			Premium Efficient			Disc. Sym
		Frame	List	Type	Frame	List	Type	
3	635	182LP	\$2,848	LVE-9	182LP	\$2,958	LVS-9	7IN
5	750	184LP	\$3,733	LVE-9	184LP	\$3,888	LVS-9	7IN
7.5	850	213LP	\$4,777	LVE-9	213LP	\$4,975	LVS-9	7IN
10	900	215LP	\$5,270	LVE-9	215LP	\$5,493	LVS-9	7IN
15	950	254LP	\$6,622	LVE-9	254LP	\$6,878	LVS-9	7IN
20	1050	256LP	\$7,338	LVE-9	256LP	\$7,629	LVS-9	7IN
25	1200	284LP	\$8,603	LVE-9	284LP	\$8,915	LVS-9	7IN
30	1250	286LP	\$9,385	LVE-9	286LP	\$9,737	LVS-9	7IN
40	1325	324LP	\$10,826	LVE-9	324LP	\$11,208	LVS-9	7IN
50	1400	326LP	\$12,251	LVE-9	326LP	\$12,704	LVS-9	7IN
60	1450	364LP	\$14,969	LVE-9	364LP	\$15,507	LVS-9	7IN
75	1500	365LP	\$18,012	LVE-9	365LP	\$18,667	LVS-9	7IN
100	1550	405LP	\$22,559	LVE-9	405LP	\$23,442	LVS-9	7IN
125	1650	444LP	\$28,875	LVE-9	444LP	\$30,014	LVS-9	7IN
150	1700	447LP	\$33,920	LVE-9	447LP	\$35,312	LVS-9	7IN
200	1700	447LP	\$44,976	LVE-9	447LP	\$46,920	LVS-9	7IN

Rated 2 Years, 17500 Hours L-10 Life
 & Standard Voltages Thru 405 Frame; 444 Frame & Larger, Single Voltage 460 or 575 is Standard

See Page M-84 For Available And Alternate BD Dimensions

* 60Hz 3600, 1800, 1200 & 900 RPM motors comply with U.S. D.O.E.'s Efficiency regulation 10 CFR Section 431 Subpart B – electric motors (See Page M-80 - M-81 for Nominal Efficiency Table)



† All marks shown within this document are properties of their respective owners.

Three Phase Modifiable Motors
Vertical Solid Shaft
Medium Thrust, In-Line
Hazardous Location
6 Pole, 1200 RPM



APPLICATIONS:

For use on Booster Pumps

FEATURES:

- * UL Listed Division 1, Class 1, Group D
- * Class F Insulation, Class B Rise at Full Load (Sine Wave Power)
- * 1.00 Service Factor (Sine Wave Power)
- * Maximum 40 Deg. C. Ambient, 3,300 Feet Altitude
- * 3 Phase 60 Hz
- * NEMA Design "B"
- * Continuous Up and Down Thrust Protection

230/460, 575 Volts (&)

HP	Down Thrust (lbs)(#)	Energy Efficient			Premium Efficient			Disc. Sym
		Frame	List	Type	Frame	List	Type	
3	840	213LP	\$3,848	LVE-9	213LP	\$4,007	LVS-9	7IN
5	900	215LP	\$5,355	LVE-9	215LP	\$5,583	LVS-9	7IN
7.5	975	254LP	\$6,022	LVE-9	254LP	\$6,282	LVS-9	7IN
10	1100	256LP	\$7,373	LVE-9	256LP	\$7,666	LVS-9	7IN
15	1200	284LP	\$8,932	LVE-9	284LP	\$9,260	LVS-9	7IN
20	1320	286LP	\$10,352	LVE-9	286LP	\$10,753	LVS-9	7IN
25	1375	324LP	\$11,727	LVE-9	324LP	\$12,154	LVS-9	7IN
30	1430	326LP	\$12,934	LVE-9	326LP	\$13,422	LVS-9	7IN
40	1520	364LP	\$16,448	LVE-9	364LP	\$17,058	LVS-9	7IN
50	1600	365LP	\$18,640	LVE-9	365LP	\$19,361	LVS-9	7IN
60	1660	404LP	\$22,489	LVE-9	404LP	\$23,367	LVS-9	7IN
75	1720	405LP	\$25,583	LVE-9	405LP	\$26,613	LVS-9	7IN
100	1750	444LP	\$33,941	LVE-9	444LP	\$35,333	LVS-9	7IN
125	1780	447LP	\$39,756	LVE-9	447LP	\$41,439	LVS-9	7IN
150	1780	447LP	\$48,859	LVE-9	447LP	\$50,950	LVS-9	7IN

Rated 2 Years, 17500 Hours L-10 Life
 & Standard Voltages Thru 405 Frame; 444 Frame & Larger, Single Voltage 460 or 575 is Standard

See Page M-84 For Available And Alternate BD Dimensions

* 60Hz 3600, 1800, 1200 & 900 RPM motors comply with U.S. D.O.E.'s Efficiency regulation 10 CFR Section 431 Subpart B – electric motors (See Page M-80 - M-81 for Nominal Efficiency Table)



**Three Phase Modifiable Motors
Vertical Solid Shaft
Aerator
Totally Enclosed Fan Cooled (TEFC)
4 Pole, 1800 RPM**



APPLICATIONS:

For use on Aerators

FEATURES:

- * Class F Insulation, Class B Rise at Full Load (Sine Wave Power)
- * 1.15 Service Factor (Sine Wave Power)
- * Maximum 40 Deg. C. Ambient, 3,300 Feet Altitude
- * NEMA Design "B"
- * 3 Phase 60 Hz
- * Cast Iron CORRO-DUTY® Construction

200, 230/460, 575 Volts

HP	Down Thrust (lbs)	Energy Efficient			Premium Efficient			Disc. Sym
		Frame	List	Type	Frame	List	Type	
5	490	184LP	\$3,411	TVCE-9	184LP	\$3,580	TVCS-9	7IN
7.5	560	213LP	\$4,347	TVCE-9	213LP	\$4,566	TVCS-9	7IN
10	640	215LP	\$4,892	TVCE-9	215LP	\$5,136	TVCS-9	7IN
15	640	254LP	\$5,634	TVCE-9	254LP	\$5,915	TVCS-9	7IN
20	640	256LP	\$6,420	TVCE-9	256LP	\$6,742	TVCS-9	7IN
25	640	284LP	\$6,885	TVCE-9	284LP	\$7,230	TVCS-9	7IN
30	640	286LP	\$7,742	TVCE-9	286LP	\$8,129	TVCS-9	7IN
40	640	324LP	\$8,399	TVCE-9	324LP	\$8,819	TVCS-9	7IN
50	640	326LP	\$9,967	TVCE-9	326LP	\$10,465	TVCS-9	7IN
60	640	364LP	\$11,819	TVCE-9	364LP	\$12,390	TVCS-9	7IN
75	640	365LP	\$14,390	TVCE-9	365LP	\$15,108	TVCS-9	7IN
100	720	405LP	\$19,394	TVCE-9	405LP	\$20,364	TVCS-9	7IN
125	720	444LP	\$26,613	TVCE-9	444LP	\$27,944	TVCS-9	7IN
150	720	447LP	\$32,505	TVCE-9	447LP	\$34,131	TVCS-9	7IN
200	720	447LP	\$45,425	TVCE-9	447LP	\$47,695	TVCS-9	7IN

& Standard Voltages Thru 405 Frame; 444 Frame & Larger, Single Voltage 460 or 575 is Standard

See Page M-84 For Available And Alternate BD Dimensions

* 60Hz 3600, 1800, 1200 & 900 RPM motors comply with U.S. D.O.E.'s Efficiency regulation 10 CFR Section 431 Subpart B – electric motors (See Page M-80 - M-81 for Nominal Efficiency Table)



Three Phase Modifiable Motors
Vertical Solid Shaft
Aerator
Totally Enclosed Fan Cooled (TEFC)
6 Pole, 1200 RPM



APPLICATIONS:

For use on Aerators

FEATURES:

- * Class F Insulation, Class B Rise at Full Load (Sine Wave Power)
- * 1.15 Service Factor (Sine Wave Power)
- * Maximum 40 Deg. C. Ambient, 3,300 Feet Altitude
- * NEMA Design "B"
- * 3 Phase 60 Hz
- * Cast Iron CORRO-DUTY® Construction

200, 230/460, 575 Volts (&)

HP	Down Thrust (lbs)	Energy Efficient			Premium Efficient			Disc. Sym
		Frame	List	Type	Frame	List	Type	
5	600	215LP	\$4,988	TVCE-9	215LP	\$5,237	TVCS-9	7IN
7.5	720	254LP	\$5,718	TVCE-9	254LP	\$6,005	TVCS-9	7IN
10	720	256LP	\$6,458	TVCE-9	256LP	\$6,782	TVCS-9	7IN
15	720	284LP	\$7,242	TVCE-9	284LP	\$7,603	TVCS-9	7IN
20	720	286LP	\$8,803	TVCE-9	286LP	\$9,244	TVCS-9	7IN
25	800	324LP	\$9,392	TVCE-9	324LP	\$9,862	TVCS-9	7IN
30	800	326LP	\$10,716	TVCE-9	326LP	\$11,251	TVCS-9	7IN
40	800	364LP	\$13,444	TVCE-9	364LP	\$14,115	TVCS-9	7IN
50	800	365LP	\$15,857	TVCE-9	365LP	\$16,650	TVCS-9	7IN
60	960	404LP	\$19,312	TVCE-9	404LP	\$20,277	TVCS-9	7IN
75	960	405LP	\$22,718	TVCE-9	405LP	\$23,854	TVCS-9	7IN
100	960	444LP	\$32,016	TVCE-9	444LP	\$33,617	TVCS-9	7IN
125	960	447LP	\$38,700	TVCE-9	447LP	\$40,636	TVCS-9	7IN
150	960	447LP	\$48,089	TVCE-9	447LP	\$50,495	TVCS-9	7IN

& Standard Voltages Thru 405 Frame; 444 Frame & Larger, Single Voltage 460 or 575 is Standard

See Page M-84 For Available And Alternate BD Dimensions

* 60Hz 3600, 1800, 1200 & 900 RPM motors comply with U.S. D.O.E.'s Efficiency regulation 10 CFR Section 431 Subpart B – electric motors (See Page M-80 - M-81 for Nominal Efficiency Table)



Three Phase Modifiable Motors
Vertical Solid Shaft
Aerator
Totally Enclosed Fan Cooled (TEFC)
8 Pole, 900 RPM



APPLICATIONS:

For use on Aerators

FEATURES:

- * Class F Insulation, Class B Rise at Full Load (Sine Wave Power)
- * 1.15 Service Factor (Sine Wave Power)
- * Maximum 40 Deg. C. Ambient, 3,300 Feet Altitude
- * NEMA Design "B"
- * 3 Phase 60 Hz
- * Cast Iron CORRO-DUTY® Construction

200, 230/460, 575 Volts (&)

HP	Down Thrust (lbs)	Energy Efficient			Premium Efficient			Disc. Sym
		Frame	List	Type	Frame	List	Type	
5	800	254LP	\$5,756	TVCE-9	254LP	\$6,045	TVCS-9	7IN
7.5	800	256LP	\$6,634	TVCE-9	256LP	\$6,965	TVCS-9	7IN
10	800	284LP	\$7,887	TVCE-9	284LP	\$8,282	TVCS-9	7IN
15	880	286LP	\$8,974	TVCE-9	286LP	\$9,423	TVCS-9	7IN
20	880	324LP	\$10,286	TVCE-9	324LP	\$10,800	TVCS-9	7IN
25	880	326LP	\$11,047	TVCE-9	326LP	\$11,599	TVCS-9	7IN
30	880	364LP	\$12,810	TVCE-9	364LP	\$13,451	TVCS-9	7IN
40	880	365LP	\$15,437	TVCE-9	365LP	\$16,209	TVCS-9	7IN
50	1120	404LP	\$18,763	TVCE-9	404LP	\$19,702	TVCS-9	7IN
60	1120	405LP	\$21,723	TVCE-9	405LP	\$22,786	TVCS-9	7IN
75	1120	444LP	\$27,700	TVCE-9	444LP	\$29,085	TVCS-9	7IN
100	1120	447LP	\$34,054	TVCE-9	447LP	\$35,756	TVCS-9	7IN
125	1120	447LP	\$55,087	TVCE-9	447LP	\$57,840	TVCS-9	7IN

& Standard Voltages Thru 405 Frame; 444 Frame & Larger, Single Voltage 460 or 575 is Standard

See Page M-84 For Available And Alternate BD Dimensions

* 60Hz 3600, 1800, 1200 & 900 RPM motors comply with U.S. D.O.E.'s Efficiency regulation 10 CFR Section 431 Subpart B – electric motors (See Page M-80 - M-81 for Nominal Efficiency Table)



Three Phase Modifiable Motors
Vertical Solid Shaft
Normal Thrust - "P" Base
Weather Protected Type I (WPI)
2 Pole, 3600 RPM



APPLICATIONS:

For use on Turbine, Mix Flow and Propeller Pumps

FEATURES:

- * Class F Insulation, Class B Rise at Full Load (Sine Wave Power)
- * 1.15 Service Factor (Sine Wave Power)
- * Maximum 40 Deg. C. Ambient, 3,300 Feet Altitude
- * NEMA Design "B"
- * 3 Phase 60 Hz
- * Both HP & VP Shaft Extension Available

200, 230/460, 575 Volts (&)

HP	Down Thrust (lbs)	Energy Efficient			Premium Efficient			Disc. Sym
		Frame	List	Type	Frame	List	Type	
5	310	182HP	\$2,101	AVE	182HP	\$2,212	AVS	7NM
7.5	380	184HP	\$2,359	AVE	184HP	\$2,484	AVS	7NM
10	450	213HP	\$2,746	AVE	213HP	\$2,890	AVS	7NM
15	520	215HP	\$3,084	AVE	215HP	\$3,247	AVS	7NM
20	520	254HP	\$3,548	AVE	254HP	\$3,735	AVS	7NM
25	600	256HP	\$3,816	AVE	256HP	\$4,017	AVS	7NM
30	600	284HP	\$4,246	AVE	284HP	\$4,470	AVS	7NM
40	600	286HP	\$5,168	AVE	286HP	\$5,440	AVS	7NM
50	600	324HP	\$6,092	RVE	324HP	\$6,413	RVS	7NM
60	600	326HP	\$6,586	RVE	326HP	\$6,933	RVS	7NM
75	600	364HP	\$7,645	RVE	364HP	\$8,047	RVS	7NM
100	600	365HP	\$10,772	RVE	365HP	\$11,339	RVS	7NM
125	720	404HP	\$13,566	RVE	404HP	\$14,279	RVS	7NM
150	720	405HP	\$18,910	RVE	405HP	\$19,905	RVS	7NM

& Standard Voltages Thru 405 Frame
 * Alternate "Z" option available for shaft. See Dimension Pages for Detail.

See Page M-83 For Available And Alternate BD Dimensions

* 60Hz 3600, 1800, 1200 & 900 RPM motors comply with U.S. D.O.E.'s Efficiency regulation 10 CFR Section 431 Subpart B – electric motors (See Page M-80 - M-81 for Nominal Efficiency Table)



Three Phase Modifiable Motors
Vertical Solid Shaft
Normal Thrust - "P" Base
Weather Protected Type I (WPI)
4 Pole, 1800 RPM



APPLICATIONS:

For use on Turbine, Mix Flow and Propeller Pumps

FEATURES:

- * Class F Insulation, Class B Rise at Full Load (Sine Wave Power)
- * 1.15 Service Factor (Sine Wave Power)
- * Maximum 40 Deg. C. Ambient, 3,300 Feet Altitude
- * NEMA Design "B"
- * 3 Phase 60 Hz
- * Both HP & VP Shaft Extension Available on 447 Frame and Lower

200, 230/460 575 Volts (&)

HP	Down Thrust (lbs)	Standard Efficient			Energy Efficient			Premium Efficient			Disc. Sym
		Frame	List	Type	Frame	List	Type	Frame	List	Type	
3	390	---	---	---	182HP	\$1,951	AVE	182HP	\$2,180	AVS	7NM
5	490	---	---	---	184HP	\$2,191	AVE	184HP	\$2,450	AVS	7NM
7.5	560	---	---	---	213HP	\$2,550	AVE	213HP	\$2,850	AVS	7NM
10	640	---	---	---	215HP	\$2,864	AVE	215HP	\$3,202	AVS	7NM
15	640	---	---	---	254HP	\$3,295	AVE	254HP	\$3,683	AVS	7NM
20	640	---	---	---	256HP	\$3,612	AVE	256HP	\$4,196	AVS	7NM
25	640	---	---	---	284HP*	\$4,110	AVE	284HP*	\$4,991	AVS	7NM
30	640	---	---	---	286HP*	\$4,478	AVE	286HP*	\$5,846	AVS	7NM
40	640	---	---	---	324HP	\$6,039	RVE	324HP	\$6,766	RVS	7NM
50	640	---	---	---	326HP	\$6,729	RVE	326HP	\$7,538	RVS	7NM
60	640	---	---	---	364HP*	\$8,026	RVE	364HP*	\$9,932	RVS	7NM
75	640	---	---	---	365HP*	\$8,648	RVE	365HP*	\$11,296	RVS	7NM
100	720	---	---	---	404HP*	\$10,315	RVE	404HP*	\$13,329	RVS	7NM
125	720	---	---	---	405HP*	\$12,841	RVE	405HP*	\$15,116	RVS	7NM
150	720	---	---	---	444HP	\$16,731	RVE	444HP	\$19,391	RVS	7NM
200	720	---	---	---	445HP	\$21,445	RVE	445HP	\$22,438	RVS	7NM
250	720	---	---	---	445HP	\$27,281	RVE	445HP	\$26,104	RVS	7NM
300	720	---	---	---	447HP@	\$31,373	RVE	447HP@	\$32,630	RVS	7NM
350	720	---	---	---	447HP@	\$35,294	RVE	447HP@	\$39,971	RVS	7NM
400	2400	5008VP	\$45,857	RV	5008VP	\$54,451	RV	5008VP	\$57,317	RVE	8VM
450	2400	5008VP	\$51,575	RV	5008VP	\$61,246	RV	5008VP	\$64,469	RVE	8VM
500	2400	5008VP	\$52,063	RV	5008VP	\$61,823	RV	5008VP	\$65,077	RVE	8VM
600	2400	5008VP	\$67,948	RV	---	---	---	5012VP	\$85,937	RVE	8VM

& Standard Voltages Thru 405 Frame; 444 Frame & Larger, Single Voltage 460 or 575 standard
 @Contact your Nidec Motor Corporation Technical Representative for WPII frame size confirmation prior to quoting.
 * Alternate "Z" Option Available for Shaft. See Dimension Pages for Detail
 See Page M-83 For Available And Alternate BD Dimensions
 † 60Hz 3600, 1800, 1200 & 900 RPM motors comply with U.S. D.O.E.'s Efficiency regulation 10 CFR Section 431 Subpart B – electric motors (See Page M-80 - M-81 for Nominal Efficiency Table)



† All marks shown within this document are properties of their respective owners.

Three Phase Modifiable Motors
Vertical Solid Shaft
Normal Thrust - "P" Base
Weather Protected Type I (WPI)
6 Pole, 1200 RPM



APPLICATIONS:

For use on Turbine, Mix Flow and Propeller Pumps

FEATURES:

- * Class F Insulation, Class B Rise at Full Load (Sine Wave Power)
- * 1.15 Service Factor (Sine Wave Power)
- * Maximum 40 Deg. C. Ambient, 3,300 Feet Altitude

- * NEMA Design "B"
- * 3 Phase 60 Hz
- * Both HP & VP Shaft Extension Available on 447 Frame and Smaller

200, 230/460 575 Volts (&)

HP	Down Thrust (lbs)	Standard Efficient			Energy Efficient			Premium Efficient			Disc. Sym
		Frame	List	Type	Frame	List	Type	Frame	List	Type	
1.5	400	---	---	---	182HP	\$2,071	AVE	182HP	\$2,180	AVS	7NM
2	450	---	---	---	184HP	\$2,327	AVE	184HP	\$2,450	AVS	7NM
3	560	---	---	---	213HP	\$2,707	AVE	213HP	\$2,850	AVS	7NM
5	600	---	---	---	215HP	\$3,041	AVE	215HP	\$3,202	AVS	7NM
7.5	700	---	---	---	254HP	\$3,498	AVE	254HP	\$3,683	AVS	7NM
10	720	---	---	---	256HP	\$3,986	AVE	256HP	\$4,196	AVS	7NM
15	720	---	---	---	284HP*	\$4,741	AVE	284HP*	\$4,991	AVS	7NM
20	720	---	---	---	286HP*	\$5,554	AVE	286HP*	\$5,846	AVS	7NM
25	800	---	---	---	324HP	\$6,428	RVE	324HP	\$6,766	RVS	7NM
30	800	---	---	---	326HP	\$7,162	RVE	326HP	\$7,538	RVS	7NM
40	800	---	---	---	364HP*	\$9,435	RVE	364HP*	\$9,932	RVS	7NM
50	800	---	---	---	365HP*	\$10,731	RVE	365HP*	\$11,296	RVS	7NM
60	960	---	---	---	404HP*	\$12,663	RVE	404HP*	\$13,329	RVS	7NM
75	960	---	---	---	405HP*	\$14,360	RVE	405HP*	\$15,116	RVS	7NM
100	960	---	---	---	444HP	\$18,422	RVE	444HP	\$19,391	RVS	7NM
125	960	---	---	---	445HP	\$21,317	RVE	445HP	\$22,438	RVS	7NM
150	960	---	---	---	445HP	\$24,979	RVE	445HP	\$26,104	RVS	7NM
200	960	---	---	---	447HP@	\$30,999	RVE	447HP@	\$32,630	RVS	7NM
250	960	---	---	---	447HP@	\$37,972	RVE	447HP@	\$39,971	RVS	7NM
300	2900	5008VP	\$45,387	RV	5008VP	\$54,293	RV	5008VP	\$57,150	RVE	8VM
350	2900	5008VP	\$52,606	RV	5008VP	\$62,874	RV	5008VP	\$66,183	RVE	8VM
400	2900	5008VP	\$60,418	RV	5012VP	\$72,173	RV	5012VP	\$75,972	RVE	8VM
450	2900	5012VP	\$66,901	RV	5012VP	\$79,981	RV	5012VP	\$84,190	RVE	8VM
500	2900	5012VP	\$73,681	RV	5012VP	\$86,341	RV	5012VP	\$90,885	RVE	8VM
600	2900	5012VP	\$88,399	RV	---	---	---	5012VP	\$110,505	RVE	8VM

& Standard Voltages Thru 405 Frame; 444 Frame & Larger, Single Voltage 460 or 575 is standard
 @Contact your Nidec Motor Corporation Technical Representative for WPII frame size confirmation prior to quoting.
 *Alternate "Z" option available for shaft. See Dimension Pages for Detail.

See Page M-83 For Available And Alternate BD Dimensions

* 60Hz 3600, 1800, 1200 & 900 RPM motors comply with U.S. D.O.E.'s Efficiency regulation 10 CFR Section 431 Subpart B – electric motors (See Page M-80 - M-81 for Nominal Efficiency Table)



Three Phase Modifiable Motors
Vertical Solid Shaft
Normal Thrust - "P" Base
Weather Protected Type I (WPI)
8 Pole, 900 RPM



APPLICATIONS:

For use on Turbine, Mix Flow and Propeller Pumps

FEATURES:

- * Class F Insulation, Class B Rise at Full Load (Sine Wave Power)
- * 1.15 Service Factor (Sine Wave Power)
- * Maximum 40 Deg. C. Ambient, 3,300 Feet Altitude
- * NEMA Design "B"
- * 3 Phase 60 Hz
- * Both HP & VP Shaft Extension Available on 447 Frame and Smaller

200, 230/460, 575 Volts (&)

HP	Down Thrust (lbs)	Standard Efficient			Energy Efficient			Premium Efficient			Disc. Sym
		Frame	List	Type	Frame	List	Type	Frame	List	Type	
1.5	520	---	---	---	184HP	\$1,861	AVE	184HP	\$1,958	AVS	7NM
2	610	---	---	---	213HP	\$1,999	AVE	213HP	\$2,104	AVS	7NM
3	700	---	---	---	215HP	\$3,084	AVE	215HP	\$3,246	AVS	7NM
5	800	---	---	---	254HP	\$3,634	AVE	254HP	\$3,825	AVS	7NM
7.5	800	---	---	---	256HP	\$4,071	AVE	256HP	\$4,285	AVS	7NM
10	800	---	---	---	284HP*	\$4,640	AVE	284HP*	\$4,884	AVS	7NM
15	880	---	---	---	286HP*	\$5,643	AVE	286HP*	\$5,940	AVS	7NM
20	880	---	---	---	324HP	\$6,611	RVE	324HP	\$6,959	RVS	7NM
25	880	---	---	---	326HP	\$7,425	RVE	326HP	\$7,817	RVS	7NM
30	880	---	---	---	364HP*	\$9,139	RVE	364HP*	\$9,620	RVS	7NM
40	880	---	---	---	365HP*	\$10,565	RVE	365HP*	\$11,121	RVS	7NM
50	1120	---	---	---	404HP*	\$12,455	RVE	404HP*	\$13,111	RVS	7NM
60	1120	---	---	---	405HP*	\$13,902	RVE	405HP*	\$14,634	RVS	7NM
75	1120	---	---	---	444HP	\$15,711	RVE	444HP	\$16,538	RVS	7NM
100	1120	---	---	---	445HP	\$20,186	RVE	445HP	\$21,248	RVS	7NM
125	1120	---	---	---	447HP@	\$28,260	RVE	447HP@	\$29,748	RVS	7NM
150	1120	---	---	---	447HP@	\$31,793	RVE	447HP@	\$33,467	RVS	7NM
200	3300	---	---	---	5008VP	\$42,429	RV	5008VP	\$44,662	RVE	8VM
250	3300	5008VP	\$47,096	RV	5012VP	\$51,454	RV	5012VP	\$54,162	RVE	8VM
300	3300	5012VP	\$55,702	RV	5012VP	\$60,853	RV	5012VP	\$64,056	RVE	8VM
350	3300	5012VP	\$64,718	RV	5012VP	\$70,704	RV	5012VP	\$74,425	RVE	8VM
400	3300	5012VP	\$73,387	RV	5012VP	\$80,177	RV	5012VP	\$84,397	RVE	8VM
450	3300	5012VP	\$81,932	RV	5012VP	\$89,510	RV	5012VP	\$94,221	RVE	8VM
500	3300	5012VP	\$90,620	RV	5012VP	\$99,000	RV	5012VP	\$104,211	RVE	8VM
600	4400	5813VPA	\$128,305	RV	---	---	---	5813VPA	\$145,824	RVE	8VM

& Standard Voltages Thru 405 Frame; 444 Frame & Larger, Single Voltage 460 or 575 is standard

* Alternate "Z" option available for shaft. See Dimension Pages for Detail.

@Contact your Nidec Motor Corporation Technical Representative for WPII frame size confirmation prior to quoting.

See Page M-83 For Available And Alternate BD Dimensions

* 60Hz 3600, 1800, 1200 & 900 RPM motors comply with U.S. D.O.E.'s Efficiency regulation 10 CFR Section 431 Subpart B – electric motors (See Page M-80 - M-81 for Nominal Efficiency Table)



† All marks shown within this document are properties of their respective owners.

Three Phase Modifiable Motors
Vertical Solid Shaft
Normal Thrust - "P" Base
Weather Protected Type I (WPI)
10 Pole, 720 RPM



APPLICATIONS:

For use on Turbine, Mix Flow and Propeller Pumps

FEATURES:

- * Class F Insulation, Class B Rise at Full Load (Sine Wave Power)
- * 1.15 Service Factor (Sine Wave Power)
- * Maximum 40 Deg. C. Ambient, 3,300 Feet Altitude
- * NEMA Design "B"
- * 3 Phase 60 Hz
- * Both HP & VP Shaft Extension Available on 447 Frames and Smaller

200, 230/460, 575 Volts (&)

HP	Down Thrust (lbs)	Standard Efficient			Premium Efficient			Disc. Sym
		Frame	List	Type	Frame	List	Type	
1.5	780	215HP	\$2,055	AV	215HP	\$2,569	AVS	7NM
2	780	215HP	\$3,171	AV	215HP	\$3,964	AVS	7NM
3	890	254HP	\$3,735	AV	254HP	\$4,669	AVS	7NM
5	890	256HP	\$4,302	AV	256HP	\$5,378	AVS	7NM
7.5	890	284HP*	\$4,567	AV	284HP*	\$5,709	AVS	7NM
10	960	324HP	\$5,814	RV	324HP	\$7,267	RVS	7NM
15	960	326HP	\$6,163	RV	326HP	\$7,704	RVS	7NM
20	960	364HP*	\$7,221	RV	364HP*	\$9,026	RVS	7NM
25	960	365HP*	\$8,319	RV	365HP*	\$10,399	RVS	7NM
30	1240	404HP*	\$9,231	RV	404HP*	\$11,539	RVS	7NM
40	1240	405HP*	\$11,120	RV	405HP*	\$13,900	RVS	7NM
50	1230	444HP	\$14,433	RV	444HP	\$18,041	RVS	7NM
60	1230	445HP	\$16,700	RV	445HP	\$20,875	RVS	7NM
75	1230	445HP	\$19,428	RV	445HP	\$24,286	RVS	7NM
100	1230	447HP@	\$24,286	RV	447HP@	\$30,357	RVS	7NM
125	1230	447HP@	\$27,321	RV	447HP@	\$34,151	RVS	7NM
150	3700	5008VP	\$44,481	RV	5008VP	\$51,153	RVS	9VM
200	3700	5008VP	\$57,580	RV	5008VP	\$66,217	RVE	9VM
250	3700	5012VP	\$62,683	RV	5012VP	\$72,085	RVE	9VM
300	3700	5012VP	\$67,784	RV	5012VP	\$77,953	RVE	9VM
350	3700	5012VP	\$77,805	RV	5012VP	\$89,477	RVE	9VM
400	4100	5813VPA	\$122,148	RV	5813VPA	\$140,469	RVE	9VM
450	4100	5813VPA	\$134,627	RV	5813VPA	\$154,822	RVE	9VM
500	4100	5813VPA	\$137,754	RV	5813VPA	\$158,413	RVE	9VM
600	4100	5813VPA	\$164,789	RV	5813VPA	\$189,507	RVE	9VM

& Standard Voltages Thru 405 Frame; 444 Frame & Larger, Single Voltage 460 or 575 is standard
 * Alternate "Z" option available for shaft. See Dimension Pages for Detail.
 @Contact your Nidec Motor Corporation Technical Representative for WPII frame size confirmation prior to quoting.

See Page M-83 For Available And Alternate BD Dimensions



Three Phase Modifiable Motors
Vertical Solid Shaft
Normal Thrust - "P" Base
Weather Protected Type I (WPI)
12 Pole, 600 RPM



APPLICATIONS:

For use on Turbine, Mix Flow and Propeller Pumps

FEATURES:

- * Class F Insulation, Class B Rise at Full Load (Sine Wave Power)
- * 1.15 Service Factor (Sine Wave Power)
- * Maximum 40 Deg. C. Ambient, 3,300 Feet Altitude
- * NEMA Design "B"
- * 3 Phase 60 Hz
- * Both HP & VP Shaft Extension Available on 447 Frames and Smaller

460 or 575 Volt

HP	Down Thrust (lbs)	Standard Efficient			Premium Efficient			Disc. Sym
		Frame	List	Type	Frame	List	Type	
7.5	1020	324HP	\$5,261	RV	324HP	\$6,576	RVS	7NM
10	1020	326HP	\$6,050	RV	326HP	\$7,563	RVS	7NM
15	1020	364HP*	\$7,769	RV	364HP*	\$9,711	RVS	7NM
20	1020	365HP*	\$9,026	RV	365HP*	\$11,282	RVS	7NM
25	1330	404HP*	\$10,288	RV	404HP*	\$12,860	RVS	7NM
30	1330	405HP*	\$11,539	RV	405HP*	\$14,423	RVS	7NM
40	1330	444HP	\$13,535	RV	444HP	\$16,919	RVS	7NM
50	1330	445HP	\$15,804	RV	445HP	\$19,755	RVS	7NM
60	1330	447HP@	\$22,077	RV	447HP@	\$27,597	RVS	7NM
75	1330	447HP@	\$26,088	RV	447HP@	\$32,611	RVS	7NM
100	4100	5008VP	\$41,427	RV	5008VP	\$47,683	RVE	8VM
125	4100	5008VP	\$46,549	RV	5008VP	\$53,533	RVE	8VM
150	4100	5008VP	\$53,507	RV	5008VP	\$61,533	RVE	8VM
200	4100	5012VP	\$67,953	RV	5012VP	\$78,146	RVE	8VM
250	4100	5012VP	\$69,554	RV	5012VP	\$79,988	RVE	8VM
300	4100	5012VP	\$81,340	RV	5012VP	\$93,542	RVE	8VM
350	5200	5813VPA	\$119,695	RV	5813VPA	\$137,650	RVE	8VM
400	5200	5813VPA	\$136,359	RV	5813VPA	\$156,812	RVE	8VM
450	5200	5813VPA	\$150,751	RV	5813VPA	\$173,364	RVE	8VM

* Contact your Nidec Motor Corporation Technical Representative for WPII frame size confirmation prior to quoting.

* Alternate "Z" option available for shaft. See Dimension Pages for Detail.

See Page M-83 For Available And Alternate BD Dimensions



Three Phase Modifiable Motors
Vertical Solid Shaft
Normal Thrust - "P" Base
Weather Protected Type I (WPI)
14 Pole, 514 RPM



APPLICATIONS:

For use on Turbine, Mix Flow and Propeller Pumps

FEATURES:

- * Class F Insulation, Class B Rise at Full Load (Sine Wave Power)
- * 1.15 Service Factor (Sine Wave Power)
- * Maximum 40 Deg. C. Ambient, 3,300 Feet Altitude
- * NEMA Design "B"
- * 3 Phase 60 Hz

480 or 575 Volts (&)

HP	Down Thrust (lbs)	Standard Efficient				Premium Efficient				Disc. Sym
		Frame	BD (in)	List	Type	Frame	BD (in)	List	Type	
100	4400	5008VP	24.5	\$66,329	RV	5008VP	24.5	\$76,279	RVE	8VM
125	4400	5012VP	24.5	\$70,230	RV	5012VP	24.5	\$80,763	RVE	8VM
150	4400	5012VP	24.5	\$76,901	RV	5012VP	24.5	\$88,437	RVE	8VM
200	4400	5012VP	24.5	\$87,749	RV	5012VP	24.5	\$100,911	RVE	8VM
250	6000	5813VPA	30.5	\$103,716	RV	5813VPA	30.5	\$119,272	RVE	8VM
300	6000	5813VPA	30.5	\$114,399	RV	5813VPA	30.5	\$131,559	RVE	8VM
350	6000	5813VPA	30.5	\$136,000	RV	5813VPA	30.5	\$156,401	RVE	8VM
400	6000	5813VPA	30.5	\$149,599	RV	5813VPA	30.5	\$172,038	RVE	8VM
450	6000	5813VPA	30.5	\$164,556	RV	5813VPA	30.5	\$189,239	RVE	8VM

See Page M-83 For Available And Alternate BD Dimensions



Three Phase Modifiable Motors
Vertical Solid Shaft
Normal Thrust - "P" Base
Hazardous Location
2 Pole, 3600 RPM



APPLICATIONS:

For use on Turbine, Mix Flow and Propeller Pumps

FEATURES:

- * UL Listed Division 1, Class 1, Group D
- * Class F Insulation, Class B Rise at Full Load (Sine Wave Power)
- * 1.00 Service Factor (Sine Wave Power)
- * Maximum 40 Deg. C. Ambient, 3,300 Feet Altitude
- * NEMA Design "B"
- * 3 Phase 60 Hz
- * Both HP & VP Shaft Extension Available on 447 Frames and Smaller

200, 230/460, 575 Volts (&)

HP	Down Thrust (lbs)	Standard Efficient			Energy Efficient			Premium Efficient			Disc. Sym
		Frame	List	Type	Frame	List	Type	Frame	List	Type	
1.5	220	---	---	---	143HP	\$2,312	LVE	143HP	\$2,488	LVS	7NM
2	220	---	---	---	145HP	\$2,406	LVE	145HP	\$2,591	LVS	7NM
3	300	---	---	---	182HP	\$2,986	LVE	182HP	\$3,108	LVS	7NM
5	300	---	---	---	184HP	\$4,031	LVE	184HP	\$4,200	LVS	7NM
7.5	460	---	---	---	213HP	\$4,557	LVE	213HP	\$4,754	LVS	7NM
10	460	---	---	---	215HP	\$5,094	LVE	215HP	\$5,308	LVS	7NM
15	800	---	---	---	254HP	\$5,564	LVE	254HP	\$5,801	LVS	7NM
20	800	---	---	---	256HP	\$6,690	LVE	256HP	\$6,950	LVS	7NM
25	940	---	---	---	284HP*	\$7,617	LVE	284HP*	\$7,880	LVS	7NM
30	940	---	---	---	286HP*	\$8,164	LVE	286HP*	\$8,455	LVS	7NM
40	1090	---	---	---	324HP	\$10,561	LVE	324HP	\$10,929	LVS	7NM
50	1090	---	---	---	326HP	\$11,687	LVE	326HP	\$12,112	LVS	7NM
60	1360	---	---	---	364HP*	\$14,633	LVE	364HP*	\$15,155	LVS	7NM
75	1360	---	---	---	365HP*	\$17,930	LVE	365HP*	\$18,580	LVS	7NM
100	1825	---	---	---	405HP*	\$23,653	LVE	405HP*	\$24,587	LVS	7NM
125	1210	---	---	---	444HP	\$38,007	LVE	444HP	\$39,603	LVS	7NM
150	1210	---	---	---	447HP	\$44,929	LVE	447HP	\$46,871	LVS	7NM
200	1210	---	---	---	5008P	\$66,507	EV	5008P	\$70,007	EVE	8VM
250	1210	5008P	\$68,040	EV	5008P	\$72,410	EV	5008P	\$76,221	EVE	8VM
300	1210	5008P	\$87,592	EV	5008P	\$93,772	EV	5008P	\$98,707	EVE	8VM
350	1210	5008P	\$102,632	EV	5008P	\$110,205	EV	5008P	\$116,005	EVE	8VM
400	1210	5807P	\$127,033	EV	5807P	\$135,941	EV	5807P	\$143,096	EVE	8VM
450	1210	5809P	\$140,554	EV	5809P	\$149,959	EV	5809P	\$157,852	EVE	8VM
500	1210	5811P	\$156,744	EV	5811P	\$167,166	EV	5811P	\$175,964	EVE	8VM
600	1210	5811P	\$182,373	EV	---	---	---	5811P	\$205,436	EVE	8VM

& Standard Voltages Thru 405 Frame; 444 Frame & Larger, Single Voltage 460 or 575 is Standard

*Alternate "Z" Option Available for Shaft. See Dimension Pages for Details

**Alternate C-Face and D-Flange Options Available on 449 and 5800 Frames

See Page M-84 For Available And Alternate BD Dimensions

* 60Hz 3600, 1800, 1200 & 900 RPM motors comply with U.S. D.O.E.'s Efficiency regulation 10 CFR Section 431 Subpart B – electric motors (See Page M-80 - M-81 for Nominal Efficiency Table)



Three Phase Modifiable Motors
Vertical Solid Shaft
Normal Thrust - "P" Base
Hazardous Location
4 Pole, 1800 RPM

VSS-NT Hazardous Location 1800 RPM 460V
--

APPLICATIONS:

For use on Turbine, Mix Flow and Propeller Pumps

FEATURES:

- * UL Listed Division 1, Class 1, Group D
- * Class F Insulation, Class B Rise at Full Load (Sine Wave Power)
- * 1.00 Service Factor (Sine Wave Power)
- * Maximum 40 Deg. C. Ambient, 3,300 Feet Altitude
- * NEMA Design "B"
- * 3 Phase 60 Hz
- * Both HP & VP Shaft Extension Available on 447 Frame and Smaller

200, 230/460 575 Volts (&)

HP	Down Thrust (lbs)	Standard Efficient			Energy Efficient			Premium Efficient			Disc. Sym
		Frame	List	Type	Frame	List	Type	Frame	List	Type	
1	300	---	---	---	143HP	\$1,925	LVE	143HP	\$2,061	LVS	7NM
1.5	300	---	---	---	145HP	\$2,136	LVE	145HP	\$2,293	LVS	7NM
2	300	---	---	---	145HP	\$2,347	LVE	145HP	\$2,525	LVS	7NM
3	420	---	---	---	182HP	\$2,758	LVE	182HP	\$2,864	LVS	7NM
5	420	---	---	---	184HP	\$3,608	LVE	184HP	\$3,756	LVS	7NM
7.5	635	---	---	---	213HP	\$4,618	LVE	213HP	\$4,808	LVS	7NM
10	635	---	---	---	215HP	\$5,094	LVE	215HP	\$5,308	LVS	7NM
15	1110	---	---	---	254HP	\$6,415	LVE	254HP	\$6,662	LVS	7NM
20	1110	---	---	---	256HP	\$7,105	LVE	256HP	\$7,385	LVS	7NM
25	1295	---	---	---	284HP*	\$8,352	LVE	284HP*	\$8,652	LVS	7NM
30	1295	---	---	---	286HP*	\$9,103	LVE	286HP*	\$9,441	LVS	7NM
40	1395	---	---	---	324HP	\$10,915	LVE	324HP	\$11,302	LVS	7NM
50	1395	---	---	---	326HP	\$12,352	LVE	326HP	\$12,809	LVS	7NM
60	1800	---	---	---	364HP*	\$15,089	LVE	364HP*	\$15,631	LVS	7NM
75	1800	---	---	---	365HP*	\$18,162	LVE	365HP*	\$18,824	LVS	7NM
100	2300	---	---	---	405HP*	\$22,759	LVE	405HP*	\$23,651	LVS	7NM
125	1530	---	---	---	444HP	\$29,244	LVE	444HP	\$30,401	LVS	7NM
150	1530	---	---	---	447HP	\$34,368	LVE	447HP	\$35,781	LVS	7NM
200	1530	---	---	---	447HP	\$46,542	LVE	447HP	\$48,516	LVS	7NM
250	1530	5008P	\$60,336	EV	5008P	\$63,992	EV	5008P	\$67,360	EVE	8VM
300	1530	5008P	\$69,695	EV	5008P	\$74,219	EV	5008P	\$78,125	EVE	8VM
350	1530	5008P	\$79,881	EV	5008P	\$85,344	EV	5008P	\$89,836	EVE	8VM
400	1530	5807P	\$95,129	EV	5807P	\$101,086	EV	5807P	\$106,406	EVE	8VM
450	1530	5807P	\$104,425	EV	5807P	\$111,241	EV	5807P	\$117,096	EVE	8VM
500	1530	5809P	\$118,747	EV	5809P	\$126,134	EV	5809P	\$132,773	EVE	8VM
600	1530	5811P	\$164,544	EV	---	---	---	5811P	\$184,934	EVE	8VM

& Standard Voltages Thru 404 Frame; 405 Frame & Larger, Single Voltage 460 or 575 standard

* Alternate "Z" Option Available for Shaft. See Dimension Pages for Detail

**Alternate C-Face and D-Flange Options Available on 449 and 5800 Frames

See Page M-84 For Available And Alternate BD Dimensions

* 60Hz 3600, 1800, 1200 & 900 RPM motors comply with U.S. D.O.E.'s Efficiency regulation 10 CFR Section 431 Subpart B – electric motors (See Page M-80 - M-81 for Nominal Efficiency Table)



† All marks shown within this document are properties of their respective owners.

Three Phase Modifiable Motors
Vertical Solid Shaft
Normal Thrust - "P" Base
Hazardous Location
6 Pole, 1200 RPM



APPLICATIONS:

For use on Turbine, Mix Flow and Propeller Pumps

FEATURES:

- * UL Listed Division 1, Class 1, Group D
- * Class F Insulation, Class B Rise at Full Load (Sine Wave Power)
- * 1.00 Service Factor (Sine Wave Power)
- * Maximum 40 Deg. C. Ambient, 3,300 Feet Altitude
- * NEMA Design "B"
- * 3 Phase 60 Hz
- * Both HP & VP Shaft Extension Available on 447 Frames and Smaller

200, 230/460 575 Volts (&)

HP	Down Thrust (lbs)	Standard Efficient			Energy Efficient			Premium Efficient			Disc. Sym
		Frame	List	Type	Frame	List	Type	Frame	List	Type	
1	360	---	---	---	145HP	\$2,408	LVE	145HP	\$2,594	LVS	7NM
1.5	500	---	---	---	182HP	\$2,605	LVE	182HP	\$2,709	LVS	7NM
2	500	---	---	---	184HP	\$3,146	LVE	184HP	\$3,334	LVS	7NM
3	775	---	---	---	213HP	\$3,721	LVE	213HP	\$3,876	LVS	7NM
5	775	---	---	---	215HP	\$5,169	LVE	215HP	\$5,388	LVS	7NM
7.5	1350	---	---	---	254HP	\$5,813	LVE	254HP	\$6,061	LVS	7NM
10	1350	---	---	---	256HP	\$7,140	LVE	256HP	\$7,422	LVS	7NM
15	1570	---	---	---	284HP*	\$8,669	LVE	284HP*	\$8,985	LVS	7NM
20	1570	---	---	---	286HP*	\$10,030	LVE	286HP*	\$10,415	LVS	7NM
25	1750	---	---	---	324HP	\$11,772	LVE	324HP	\$12,201	LVS	7NM
30	1750	---	---	---	326HP	\$13,035	LVE	326HP	\$13,528	LVS	7NM
40	2200	---	---	---	364HP*	\$16,589	LVE	364HP*	\$17,206	LVS	7NM
50	2200	---	---	---	365HP*	\$18,802	LVE	365HP*	\$19,533	LVS	7NM
60	2825	---	---	---	404HP*	\$22,688	LVE	404HP*	\$23,576	LVS	7NM
75	2825	---	---	---	405HP*	\$25,813	LVE	405HP*	\$26,857	LVS	7NM
100	1930	---	---	---	444HP	\$33,941	LVE	444HP	\$35,333	LVS	7NM
125	1930	---	---	---	447HP	\$39,756	LVE	447HP	\$41,439	LVS	7NM
150	1930	---	---	---	447HP	\$48,859	LVE	447HP	\$50,950	LVS	7NM
200	1930	---	---	---	5008P	\$83,458	EV	5008P	\$87,850	EVE	8VM
250	1930	5008P	\$81,822	EV	5008P	\$87,469	EV	5008P	\$92,073	EVE	8VM
300	1930	5008P	\$94,604	EV	5008P	\$101,432	EV	5008P	\$106,770	EVE	8VM
350	1930	5807P	\$114,451	EV	5807P	\$122,196	EV	5807P	\$128,627	EVE	8VM
400	1930	5807P	\$129,040	EV	5807P	\$138,136	EV	5807P	\$145,406	EVE	8VM
450	1930	5809P	\$146,808	EV	5809P	\$156,793	EV	5809P	\$165,045	EVE	8VM
500	1930	5809P	\$160,315	EV	5809P	\$171,546	EV	5809P	\$180,575	EVE	8VM
600	1930	5811P	\$190,706	EV	---	---	---	5811P	\$215,018	EVE	8VM

& Standard Voltages Thru 404 Frame; 405 Frame & Larger, Single Voltage 460 or 575 standard

* Alternate "Z" Option Available for Shaft. See Dimension Pages for Detail

**Alternate C-Face and D-Flange Options Available on 449 and 5800 Frames

See Page M-84 For Available And Alternate BD Dimensions

* 60Hz 3600, 1800, 1200 & 900 RPM motors comply with U.S. D.O.E.'s Efficiency regulation 10 CFR Section 431 Subpart B – electric motors (See Page M-80 - M-81 for Nominal Efficiency Table)



† All marks shown within this document are properties of their respective owners.

Three Phase Modifiable Motors
Vertical Solid Shaft
Normal Thrust - "P" Base
Hazardous Location
8 Pole, 900 RPM

VSS-NT Hazardous Location 900 RPM 460V
--

APPLICATIONS:

For use on Turbine, Mix Flow and Propeller Pumps

FEATURES:

- * UL Listed Division 1, Class 1, Group D
- * Class F Insulation, Class B Rise at Full Load (Sine Wave Power)
- * 1.00 Service Factor (Sine Wave Power)
- * Maximum 40 Deg. C. Ambient, 3,300 Feet Altitude
- * NEMA Design "B"
- * 3 Phase 60 Hz
- * Both HP & VP Shaft Extension Available on 447 Frames and Smaller

200, 230/460, 575 Volts (&)

HP	Down Thrust (lbs)	Standard Efficient			Energy Efficient			Premium Efficient			Disc. Sym
		Frame	List	Type	Frame	List	Type	Frame	List	Type	
1.5	570	---	---	---	184HP	\$3,608	LVE	---	---	---	7NM
2	860	---	---	---	213HP	\$3,956	LVE	213HP	\$4,122	LVS	7NM
3	860	---	---	---	215HP	\$5,094	LVE	215HP	\$5,308	LVS	7NM
5	1540	---	---	---	254HP	\$5,857	LVE	254HP	\$6,108	LVS	7NM
7.5	1540	---	---	---	256HP	\$7,288	LVE	256HP	\$7,577	LVS	7NM
10	1740	---	---	---	284HP*	\$8,387	LVE	284HP*	\$8,732	LVS	7NM
15	1740	---	---	---	286HP*	\$10,176	LVE	286HP*	\$10,568	LVS	7NM
20	1945	---	---	---	324HP	\$12,133	LVE	324HP	\$12,579	LVS	7NM
25	1945	---	---	---	326HP	\$13,485	LVE	326HP	\$14,000	LVS	7NM
30	2515	---	---	---	364HP*	\$16,087	LVE	364HP*	\$16,680	LVS	7NM
40	2515	---	---	---	365HP*	\$18,521	LVE	365HP*	\$19,237	LVS	7NM
50	3230	---	---	---	404HP*	\$22,303	LVE	404HP*	\$23,172	LVS	7NM
60	3230	---	---	---	405HP*	\$24,977	LVE	405HP*	\$25,979	LVS	7NM
75	2240	---	---	---	444HP	\$31,241	LVE	444HP	\$32,497	LVS	7NM
100	2240	---	---	---	447HP	\$39,835	LVE	447HP	\$41,523	LVS	7NM
125	2240	---	---	---	447HP	\$54,943	LVE	447HP	\$57,338	LVS	7NM
150	2240	---	---	---	5008P	\$83,259	EV	5008P	\$87,641	EVE	8VM
200	2240	---	---	---	5008P	\$94,710	EV	5008P	\$99,695	EVE	8VM
250	2240	5008P	\$97,662	EV	5008P	\$104,773	EV	5008P	\$110,287	EVE	8VM
300	2240	5807P	\$120,009	EV	5807P	\$128,268	EV	5807P	\$135,019	EVE	8VM
350	2240	5807P	\$136,807	EV	5807P	\$146,619	EV	5807P	\$154,336	EVE	8VM
400	2240	5809P	\$158,787	EV	5809P	\$169,879	EV	5809P	\$178,820	EVE	8VM
450	2240	5809P	\$172,594	EV	5809P	\$184,962	EV	5809P	\$194,697	EVE	8VM
500	2240	5811P	\$195,556	EV	5811P	\$209,568	EV	5811P	\$220,598	EVE	8VM

& Standard Voltages Thru 405 Frame; 444 Frame & Larger, Single Voltage 460 or 575 is Standard

*Alternate "Z" Option Available for Shaft. See Dimension Pages for Details

**Alternate C-Face and D-Flange Options Available on 449 and 5800 Frames

See Page M-84 For Available And Alternate BD Dimensions

* 60Hz 3600, 1800, 1200 & 900 RPM motors comply with U.S. D.O.E.'s Efficiency regulation 10 CFR Section 431 Subpart B - electric motors (See Page M-80 - M-81 for Nominal Efficiency Table)



† All marks shown within this document are properties of their respective owners.

Three Phase Modifiable Motors
Vertical Solid Shaft
Normal Thrust - "P" Base
Hazardous Location
10 Pole, 720 RPM



APPLICATIONS:

For use on Turbine, Mix Flow and Propeller Pumps

FEATURES:

- * UL Listed Division 1, Class 1, Group D
- * Class F Insulation, Class B Rise at Full Load (Sine Wave Power)
- * 1.00 Service Factor (Sine Wave Power)
- * Maximum 40 Deg. C. Ambient, 3,300 Feet Altitude
- * NEMA Design "B"
- * 3 Phase 60 Hz
- * Both HP & VP Shaft Extension Available on 447 Frames and Smaller

200, 230/460, 575 Volts (&)

HP	Down Thrust (lbs)	Standard Efficient			Premium Efficient			Disc. Sym
		Frame	List	Type	Frame	List	Type	
7.5	1700	286HP*	\$7,624	LV	286HP*	\$9,274	LVS	7NM
10	1900	324HP	\$8,385	LV	324HP	\$9,953	LVS	7NM
15	2500	364HP	\$11,535	LV	364HP	\$13,265	LVS	7NM
20	2500	364HP*	\$13,763	LV	364HP*	\$15,741	LVS	7NM
25	2500	365HP*	\$16,145	LV	365HP*	\$18,619	LVS	7NM
30	3200	405HP*	\$18,615	LV	405HP*	\$21,456	LVS	7NM
40	3200	405HP*	\$23,097	LV	405HP*	\$26,867	LVS	7NM
50	2200	444HP	\$27,260	LV	444HP	\$31,650	LVS	7NM
60	2200	444HP	\$32,631	LV	444HP	\$38,136	LVS	7NM
75	2200	447HP	\$38,612	LV	447HP	\$45,162	LVS	7NM
100	2200	5008P	\$71,355	EV	5008P	\$80,033	EVE	8VM
125	2200	5008P	\$74,059	EV	5008P	\$83,144	EVE	8VM
150	2200	5008P	\$93,975	EV	5008P	\$106,045	EVE	8VM
200	2200	5807P	\$129,368	EV	5807P	\$145,782	EVE	8VM
250	2200	5809P	\$149,343	EV	5809P	\$167,960	EVE	8VM
300	2200	5809P	\$159,449	EV	5809P	\$179,580	EVE	8VM
350	2200	5811P	\$181,711	EV	5811P	\$204,676	EVE	8VM
400	2200	5811P	\$204,901	EV	5811P	\$231,345	EVE	8VM

& Standard Voltages Thru 405 Frame; 444 Frame & Larger, Single Voltage 460 or 575 is Standard

*Alternate "Z" Option Available for Shaft. See Dimension Pages for Details

**Alternate C-Face and D-Flange Options Available on 449 and 5800 Frames

See Page M-84 For Available And Alternate BD Dimensions



Three Phase Modifiable Motors
Vertical Solid Shaft
Normal Thrust - "P" Base
Hazardous Location
12 Pole, 600 RPM

VSS-NT Hazardous Location 600 RPM 460V

APPLICATIONS:

For use on Turbine, Mix Flow and Propeller Pumps

FEATURES:

- * UL Listed Division 1, Class 1, Group D
- * Class F Insulation, Class B Rise at Full Load (Sine Wave Power)
- * 1.00 Service Factor (Sine Wave Power)
- * Maximum 40 Deg. C. Ambient, 3,300 Feet Altitude
- * NEMA Design "B"
- * 3 Phase 60 Hz
- * Both HP & VP Shaft Extension Available on 447 Frames and Smaller

200, 230/460 575 Volts (&)

HP	Down Thrust (lbs)	Standard Efficient			Premium Efficient			Disc. Sym
		Frame	List	Type	Frame	List	Type	
20	2500	365HP*	\$25,394	LV	365HP*	\$29,713	LVS	7NM
25	3200	404HP*	\$30,094	LV	404HP*	\$35,298	LVS	7NM
30	3200	405HP*	\$34,584	LV	405HP*	\$40,495	LVS	7NM
40	2200	444HP	\$43,285	LV	444HP	\$50,855	LVS	7NM
50	2200	447HP	\$46,371	LV	447HP	\$54,530	LVS	7NM
60	2200	447HP	\$49,800	LV	447HP	\$58,673	LVS	7NM
75	2200	5008P	\$73,883	EV	5008P	\$82,942	EVE	8VM
100	2200	5008P	\$89,780	EV	5008P	\$101,223	EVE	8VM
125	2200	5008P	\$105,667	EV	5008P	\$119,493	EVE	8VM
150	2200	5807P	\$125,899	EV	5807P	\$141,791	EVE	8VM
200	2200	5809P	\$159,773	EV	5809P	\$179,953	EVE	8VM
250	2200	5811P	\$166,328	EV	5811P	\$186,986	EVE	8VM
300	2200	5811P	\$189,666	EV	5811P	\$213,824	EVE	8VM

& Standard Voltages Thru 405 Frame; 444 Frame & Larger, Single Voltage 460 or 575 standard

* Alternate "Z" Option Available for Shaft. See Dimension Pages for Detail

**Alternate C-Face and D-Flange Options Available on 449 and 5800 Frames

See Page M-84 For Available And Alternate BD Dimensions



Three Phase Modifiable Motors
Vertical Solid Shaft
Normal Thrust - "P" Base
Hazardous Location
14 Pole, 514 RPM



APPLICATIONS:

For use on Turbine, Mix Flow and Propeller Pumps

FEATURES:

- * UL Listed Division 1, Class 1, Group D
- * Class F Insulation, Class B Rise at Full Load (Sine Wave Power)
- * 1.00 Service Factor (Sine Wave Power)
- * Maximum 40 Deg. C. Ambient, 3,300 Feet Altitude
- * NEMA Design "B"
- * 3 Phase 60 Hz
- * Both HP & VP Shaft Extension Available on 447 Frames and Smaller

200, 230/460, 575 Volts (&)

HP	Down Thrust (lbs)	Standard Efficient			Premium Efficient			Disc. Sym
		Frame	List	Type	Frame	List	Type	
20	3200	404HP	\$29,211	LV	404HP	\$34,178	LVS	7NM
25	3200	404HP	\$35,178	LV	404HP	\$41,162	LVS	7NM
30	2200	447HP	\$39,796	LV	447HP	\$46,591	LVS	7NM
40	2200	5008P	\$60,916	EV	5008P	\$68,029	EVE	8VM
50	2200	5008P	\$64,625	EV	5008P	\$72,294	EVE	8VM
60	2200	5008P	\$69,085	EV	5008P	\$77,423	EVE	8VM
75	2200	5008P	\$92,503	EV	5008P	\$104,352	EVE	8VM
100	2200	5807P	\$121,244	EV	5807P	\$136,439	EVE	8VM
125	2200	5807P	\$139,145	EV	5807P	\$157,023	EVE	8VM
150	2200	5809P	\$160,855	EV	5809P	\$181,197	EVE	8VM
200	2200	5811P	\$202,354	EV	5811P	\$228,415	EVE	8VM

& Standard Voltages Thru 405 Frame; 444 Frame & Larger, Single Voltage 460 or 575 is Standard

*Alternate "Z" Option Available for Shaft. See Dimension Pages for Details

**Alternate C-Face and D-Flange Options Available on 449 and 5800 Frames

See Page M-84 For Available And Alternate BD Dimensions



Three Phase Modifiable Motors
Vertical Solid Shaft / Corro-Duty
Normal Thrust - "P" Base
Totally Enclosed Fan Cooled (TEFC)
2 Pole, 3600 RPM



APPLICATIONS:

For use on Turbine, Mix Flow and Propeller Pumps

FEATURES:

- * Corro-Duty Construction (140-447 Frame)
- * Class F Insulation, Class B Rise at Full Load (Sine Wave Power)
- * 1.15 Service Factor (140-447 Frames), 1.00 Service Factor 449 frames and larger (Sine Wave Power)
- * Maximum 40 Deg. C. Ambient, 3,300 Feet Altitude
- * NEMA Design "B"
- * 3 Phase 60 Hz
- * Both HP & VP Shaft Extension Available on 447 Frames and Smaller

200, 230/460, 575 Volts (&)

HP	Down Thrust (lbs)	Standard Efficient			Energy Efficient			Premium Efficient			Disc. Sym
		Frame	List	Type	Frame	List	Type	Frame	List	Type	
1	220	---	---	---	143HP	\$1,400	TVCE	143HP	\$1,431	TVCS	7CME
1.5	220	---	---	---	143HP	\$1,400	TVCE	143HP	\$1,431	TVCS	7CME
2	300	---	---	---	145HP	\$1,549	TVCE	145HP	\$1,584	TVCS	7CME
3	350	---	---	---	182HP	\$1,825	TVCE	182HP	\$1,916	TVCS	7CME
5	350	---	---	---	184HP	\$2,091	TVCE	184HP	\$2,196	TVCS	7CME
7.5	520	---	---	---	213HP	\$2,292	TVCE	213HP	\$2,402	TVCS	7CME
10	520	---	---	---	215HP	\$2,555	TVCE	215HP	\$2,677	TVCS	7CME
15	900	---	---	---	254HP	\$3,247	TVCE	254HP	\$3,402	TVCS	7CME
20	900	---	---	---	256HP	\$3,814	TVCE	256HP	\$3,996	TVCS	7CME
25	1050	---	---	---	284HP*	\$4,758	TVCE	284HP*	\$4,986	TVCS	7CME
30	1050	---	---	---	286HP*	\$5,382	TVCE	286HP*	\$5,640	TVCS	7CME
40	1090	---	---	---	324HP	\$6,476	TVCE	324HP	\$7,042	TVCS	7CME
50	1090	---	---	---	326HP	\$7,935	TVCE	326HP	\$8,664	TVCS	7CME
60	1360	---	---	---	364HP*	\$10,551	TVCE	364HP*	\$11,523	TVCS	7CME
75	1360	---	---	---	365HP*	\$12,796	TVCE	365HP*	\$14,017	TVCS	7CME
100	1825	---	---	---	405HP*	\$17,199	TVCE	405HP*	\$18,834	TVCS	7CME
125	1210	---	---	---	444HP	\$20,798	TVCE	444HP	\$22,795	TVCS	7CME
150	1210	---	---	---	445HP	\$24,945	TVCE	445HP	\$27,403	TVCS	7CME
200	1210	---	---	---	447HP	\$30,878	TVCE	447HP	\$33,985	TVCS	7CME
250	1210	449VP	\$58,542	JV	449VP	\$59,587	JV	449VP	\$62,723	JVE	8VM
300	1210	449VP	\$74,094	JV	449VP	\$80,949	JV	449VP	\$85,209	JVE	8VM
350	1210	449VP	\$89,134	JV	449VP	\$97,099	JV	449VP	\$102,209	JVE	8VM
400	1210	5807P	\$107,080	JV	5807P	\$116,986	JV	5807P	\$123,143	JVE	8VM
450	1210	5809P	\$115,319	JV	5809P	\$125,986	JV	5809P	\$132,617	JVE	8VM
500	1210	5811P	\$128,134	JV	5811P	\$139,986	JV	5811P	\$147,354	JVE	8VM
600	1210	5811P	\$153,763	JV	---	---	---	5811P	\$176,826	JVE	8VM

& Standard Voltages Thru 405 Frame; 444 Frame & Larger, Single Voltage 460 or 575 is Standard

*Alternate "Z" Option Available for Shaft. See Dimension Pages for Details

**Alternate C-Face and D-Flange Options Available on 449 and 5800 Frames

* 60Hz 3600, 1800, 1200 & 900 RPM motors comply with U.S. D.O.E.'s Efficiency regulation 10 CFR Section 431 Subpart B – electric motors (See Page M-80 - M-81 for Nominal Efficiency Table)

See Page M-84 For Available And Alternate BD Dimensions

† All marks shown within this document are properties of their respective owners.



Three Phase Modifiable Motors
Vertical Solid Shaft / Corro-Duty
Normal Thrust - "P" Base
Totally Enclosed Fan Cooled (TEFC)
4 Pole, 1800 RPM



APPLICATIONS:

For use on Turbine, Mix Flow and Propeller Pumps

FEATURES:

- * Corro-Duty Construction (140-447 Frame)
- * Class F Insulation, Class B Rise at Full Load (Sine Wave Power)
- * 1.15 Service Factor (140-447 Frames), 1.00 Service Factor 449 frames and larger (Sine Wave Power)
- * Maximum 40 Deg. C. Ambient, 3,300 Feet Altitude
- * NEMA Design "B"
- * 3 Phase 60 Hz
- * Both HP & VP Shaft Extension Available on 447 Frames and Smaller

200, 230/460 575 Volts (&)

HP	Down Thrust (lbs)	Standard Efficient			Energy Efficient			Premium Efficient			Disc. Sym
		Frame	List	Type	Frame	List	Type	Frame	List	Type	
1	300	---	---	---	143HP	\$1,295	TVCE	143HP	\$1,322	TVCS	7CME
1.5	300	---	---	---	145HP	\$1,368	TVCE	145HP	\$1,398	TVCS	7CME
2	300	---	---	---	145HP	\$1,443	TVCE	145HP	\$1,474	TVCS	7CME
3	420	---	---	---	182HP	\$1,704	TVCE	182HP	\$1,790	TVCS	7CME
5	420	---	---	---	184HP	\$1,854	TVCE	184HP	\$1,947	TVCS	7CME
7.5	640	---	---	---	213HP	\$2,145	TVCE	213HP	\$2,248	TVCS	7CME
10	640	---	---	---	215HP	\$2,435	TVCE	215HP	\$2,551	TVCS	7CME
15	1110	---	---	---	254HP	\$3,007	TVCE	254HP	\$3,151	TVCS	7CME
20	1110	---	---	---	256HP	\$3,505	TVCE	256HP	\$3,673	TVCS	7CME
25	1380	---	---	---	284HP*	\$4,310	TVCE	284HP*	\$4,516	TVCS	7CME
30	1380	---	---	---	286HP*	\$4,836	TVCE	286HP*	\$5,067	TVCS	7CME
40	1395	---	---	---	324HP	\$5,865	TVCE	324HP	\$6,363	TVCS	7CME
50	1395	---	---	---	326HP	\$6,886	TVCE	326HP	\$7,498	TVCS	7CME
60	1800	---	---	---	364HP*	\$9,806	TVCE	364HP*	\$10,695	TVCS	7CME
75	1800	---	---	---	365HP*	\$11,981	TVCE	365HP*	\$13,113	TVCS	7CME
100	2300	---	---	---	405HP*	\$15,020	TVCE	405HP*	\$16,414	TVCS	7CME
125	1530	---	---	---	444HP	\$18,143	TVCE	444HP	\$19,845	TVCS	7CME
150	1530	---	---	---	445HP	\$21,008	TVCE	445HP	\$23,029	TVCS	7CME
200	1530	---	---	---	447HP	\$25,077	TVCE	447HP	\$27,539	TVCS	7CME
250	1530	449VP	\$46,838	JV	449VP	\$51,169	JV	449VP	\$53,862	JVE	8VM
300	1530	449VP	\$56,197	JV	449VP	\$61,396	JV	449VP	\$64,627	JVE	8VM
350	1530	449VP	\$66,383	JV	449VP	\$72,521	JV	449VP	\$76,338	JVE	8VM
400	1530	5807P	\$75,176	JV	5807P	\$82,130	JV	5807P	\$86,453	JVE	8VM
450	1530	5807P	\$84,472	JV	5807P	\$92,286	JV	5807P	\$97,143	JVE	8VM
500	1530	5809P	\$93,512	JV	5809P	\$102,161	JV	5809P	\$107,538	JVE	8VM
600	1530	5811P	\$135,934	JV	---	---	---	5811P	\$156,324	JVE	8VM
700	1530	5812VP	\$155,250	JV	---	---	---	5812VP	\$178,538	JVE	8VM
800	1530	5812VP	\$176,440	JV	---	---	---	5812VP	\$202,906	JVE	8VM

& Standard Voltages Thru 405 Frame; 444 Frame & Larger, Single Voltage 460 or 575 standard
 * Alternate "Z" Option Available for Shaft. See Dimension Pages for Detail
 **Alternate C-Face and D-Flange Options Available on 449 and 5811 Frames
 See Page M-84 For Available And Alternate BD Dimensions
 * 60Hz 3600, 1800, 1200 & 900 RPM motors comply with U.S. D.O.E.'s Efficiency regulation 10 CFR Section 431 Subpart B – electric motors (See Page M-80 - M-81 for Nominal Efficiency Table)



† All marks shown within this document are properties of their respective owners.

**Three Phase Modifiable Motors
Vertical Solid Shaft / Corro-Duty
Normal Thrust - "P" Base
Totally Enclosed Fan Cooled (TEFC)
6 Pole, 1200 RPM**



APPLICATIONS:

For use on Turbine, Mix Flow and Propeller Pumps

FEATURES:

- * Corro-Duty Construction (140-447 Frame)
- * Class F Insulation, Class B Rise at Full Load (Sine Wave Power)
- * 1.15 Service Factor (140-447 Frames), 1.00 Service Factor 449 frames and larger (Sine Wave Power)
- * Maximum 40 Deg. C. Ambient, 3,300 Feet Altitude
- * NEMA Design "B"
- * 3 Phase 60 Hz
- * Both HP & VP Shaft Extension Available on 447 Frames and Smaller

200, 230/460, 575 Volts (&)

HP	Down Thrust (lbs)	Standard Efficient			Energy Efficient			Premium Efficient			Disc. Sym
		Frame	List	Type	Frame	List	Type	Frame	List	Type	
1	360	---	---	---	145HP	\$1,542	TVCE	145HP	\$1,587	TVCS	7CME
1.5	500	---	---	---	182HP	\$1,805	TVCE	182HP	\$1,895	TVCS	7CME
2	500	---	---	---	184HP	\$1,921	TVCE	184HP	\$2,017	TVCS	7CME
3	780	---	---	---	213HP	\$2,090	TVCE	213HP	\$2,190	TVCS	7CME
5	780	---	---	---	215HP	\$2,669	TVCE	215HP	\$2,797	TVCS	7CME
7.5	1350	---	---	---	254HP	\$3,490	TVCE	254HP	\$3,657	TVCS	7CME
10	1350	---	---	---	256HP	\$4,022	TVCE	256HP	\$4,214	TVCS	7CME
15	1570	---	---	---	284HP*	\$5,111	TVCE	284HP*	\$5,356	TVCS	7CME
20	1570	---	---	---	286HP*	\$5,949	TVCE	286HP*	\$6,233	TVCS	7CME
25	1750	---	---	---	324HP	\$6,989	TVCE	324HP	\$7,605	TVCS	7CME
30	1750	---	---	---	326HP	\$7,987	TVCE	326HP	\$8,714	TVCS	7CME
40	2200	---	---	---	364HP*	\$10,250	TVCE	364HP*	\$11,188	TVCS	7CME
50	2200	---	---	---	365HP*	\$11,536	TVCE	365HP*	\$12,616	TVCS	7CME
60	2825	---	---	---	404HP*	\$13,942	TVCE	404HP*	\$15,217	TVCS	7CME
75	2825	---	---	---	405HP*	\$15,996	TVCE	405HP*	\$17,498	TVCS	7CME
100	1930	---	---	---	444HP	\$21,330	TVCE	444HP	\$23,389	TVCS	7CME
125	1930	---	---	---	445HP	\$23,599	TVCE	445HP	\$25,909	TVCS	7CME
150	1930	---	---	---	447HP	\$26,784	TVCE	447HP	\$29,435	TVCS	7CME
200	1930	449VP	\$64,655	JV	449VP	\$70,634	JV	449VP	\$74,352	JVE	8VM
250	1930	449VP	\$68,324	JV	449VP	\$74,646	JV	449VP	\$78,575	JVE	8VM
300	1930	449VP	\$81,106	JV	449VP	\$88,608	JV	449VP	\$93,272	JVE	8VM
350	1930	5807P	\$94,498	JV	5807P	\$103,240	JV	5807P	\$108,674	JVE	8VM
400	1930	5807P	\$109,087	JV	5807P	\$119,180	JV	5807P	\$125,453	JVE	8VM
450	1930	5809P	\$121,573	JV	5809P	\$132,820	JV	5809P	\$139,810	JVE	8VM
500	1930	5809P	\$135,080	JV	5809P	\$147,573	JV	5809P	\$155,340	JVE	8VM
600	1930	5811P	\$162,096	JV	---	---	---	5811P	\$186,408	JVE	8VM
700	1930	5812VP	\$203,117	JV	---	---	---	5812VP	\$233,585	JVE	8VM

& Standard Voltages Thru 405 Frame; 444 Frame & Larger, Single Voltage 460 or 575 is Standard

*Alternate "Z" Option Available for Shaft. See Dimension Pages for Details

**Alternate C-Face and D-Flange Options Available on 449 and 5811 Frames

See Page M-84 For Available And Alternate BD Dimensions

* 60Hz 3600, 1800, 1200 & 900 RPM motors comply with U.S. D.O.E.'s Efficiency regulation 10 CFR Section 431

Subpart B – electric motors (See Page M-80 - M-81 for Nominal Efficiency Table)



† All marks shown within this document are properties of their respective owners.

Three Phase Modifiable Motors
Vertical Solid Shaft / Corro-Duty
Normal Thrust - "P" Base
Totally Enclosed Fan Cooled (TEFC)
8 Pole, 900 RPM



APPLICATIONS:

For use on Turbine, Mix Flow and Propeller Pumps

FEATURES:

- * Corro-Duty Construction (140-447 Frame)
- * Class F Insulation, Class B Rise at Full Load (Sine Wave Power)
- * 1.15 Service Factor (140-447 Frames), 1.00 Service Factor 449 frames and larger (Sine Wave Power)
- * Maximum 40 Deg. C. Ambient, 3,300 Feet Altitude
- * NEMA Design "B"
- * 3 Phase 60 Hz
- * Both HP & VP Shaft Extension Available on 447 Frames and Smaller

200, 230/460 575 Volts (&)

HP	Down Thrust (lbs)	Standard Efficient			Energy Efficient			Premium Efficient			Disc. Sym
		Frame	List	Type	Frame	List	Type	Frame	List	Type	
1	570	---	---	---	182HP	\$2,210	TVCE	182HP	\$2,321	TVCS	7CME
1.5	570	---	---	---	184HP	\$2,368	TVCE	184HP	\$2,486	TVCS	7CME
2	860	---	---	---	213HP	\$2,427	TVCE	213HP	\$2,543	TVCS	7CME
3	860	---	---	---	215HP	\$2,826	TVCE	215HP	\$2,962	TVCS	7CME
5	1540	---	---	---	254HP	\$3,905	TVCE	254HP	\$4,091	TVCS	7CME
7.5	1540	---	---	---	256HP	\$4,894	TVCE	256HP	\$5,129	TVCS	7CME
10	1740	---	---	---	284HP*	\$6,005	TVCE	284HP*	\$6,293	TVCS	7CME
15	1740	---	---	---	286HP*	\$7,025	TVCE	286HP*	\$7,361	TVCS	7CME
20	1945	---	---	---	324HP	\$8,194	TVCE	324HP	\$8,945	TVCS	7CME
25	1945	---	---	---	326HP	\$9,442	TVCE	326HP	\$10,330	TVCS	7CME
30	2515	---	---	---	364HP*	\$11,090	TVCE	364HP*	\$12,113	TVCS	7CME
40	2515	---	---	---	365HP*	\$12,735	TVCE	365HP*	\$13,949	TVCS	7CME
50	3230	---	---	---	404HP*	\$16,535	TVCE	404HP*	\$18,097	TVCS	7CME
60	3230	---	---	---	405HP*	\$18,700	TVCE	405HP*	\$20,504	TVCS	7CME
75	2240	---	---	---	444HP	\$20,466	TVCE	444HP	\$22,426	TVCS	7CME
100	2240	---	---	---	445HP	\$27,759	TVCE	445HP	\$30,530	TVCS	7CME
125	2240	---	---	---	447HP	\$30,143	TVCE	447HP	\$33,168	TVCS	7CME
150	2240	---	---	---	449VP	\$70,436	JV	449VP	\$74,143	JVE	8VM
200	2240	---	---	---	449VP	\$81,887	JV	449VP	\$86,197	JVE	8VM
250	2240	449VP	\$84,164	JV	449VP	\$91,950	JV	449VP	\$96,789	JVE	8VM
300	2240	5807P	\$100,056	JV	5807P	\$109,313	JV	5807P	\$115,066	JVE	8VM
350	2240	5807P	\$116,854	JV	5807P	\$127,664	JV	5807P	\$134,383	JVE	8VM
400	2240	5809P	\$133,552	JV	5809P	\$145,906	JV	5809P	\$153,585	JVE	8VM
450	2240	5809P	\$147,359	JV	5809P	\$160,989	JV	5809P	\$169,462	JVE	8VM
500	2240	5811P	\$166,946	JV	5811P	\$182,389	JV	5811P	\$191,988	JVE	8VM
600	2240	5812VP	\$188,641	JV	---	---	---	5812VP	\$216,937	JVE	8VM

& Standard Voltages Thru 405 Frame; 444 Frame & Larger, Single Voltage 460 or 575 standard

* Alternate "Z" Option Available for Shaft. See Dimension Pages for Detail

**Alternate C-Face and D-Flange Options Available on 449 and 5811 Frames

See Page M-84 For Available And Alternate BD Dimensions

* 60Hz 3600, 1800, 1200 & 900 RPM motors comply with U.S. D.O.E.'s Efficiency regulation 10 CFR Section 431 Subpart B – electric motors (See Page M-80 - M-81 for Nominal Efficiency Table)



† All marks shown within this document are properties of their respective owners.

**Three Phase Modifiable Motors
Vertical Solid Shaft / Corro-Duty
Normal Thrust - "P" Base
Totally Enclosed Fan Cooled (TEFC)
10 Pole, 720 RPM**



APPLICATIONS:

For use on Turbine, Mix Flow and Propeller Pumps

FEATURES:

- * Corro-Duty Construction (140-447 Frame)
- * Class F Insulation, Class B Rise at Full Load (Sine Wave Power)
- * 1.15 Service Factor (140-447 Frames), 1.00 Service Factor 449 frames and larger (Sine Wave Power)
- * Maximum 40 Deg. C. Ambient, 3,300 Feet Altitude
- * NEMA Design "B"
- * 3 Phase 60 Hz
- * Both HP & VP Shaft Extension Available on 447 Frames and Smaller

200, 230/460 575 Volts (&)

HP	Down Thrust (lbs)	Standard Efficient			Premium Efficient			Disc. Sym
		Frame	List	Type	Frame	List	Type	
1	900	213HP	\$2,823	TVC	213HP	\$3,137	TVCS	7CME
1.5	900	213HP	\$3,023	TVC	213HP	\$3,359	TVCS	7CME
2	900	215HP	\$3,090	TVC	215HP	\$3,433	TVCS	7CME
3	1600	254HP	\$3,599	TVC	254HP	\$3,999	TVCS	7CME
5	1600	256HP	\$4,972	TVC	256HP	\$5,524	TVCS	7CME
7.5	1825	284HP*	\$6,233	TVC	284HP*	\$6,925	TVCS	7CME
10	1825	324HP	\$7,756	TVC	324HP	\$8,618	TVCS	7CME
15	2040	326HP	\$9,102	TVC	326HP	\$10,113	TVCS	7CME
20	2040	364HP*	\$10,868	TVC	364HP*	\$12,075	TVCS	7CME
25	2630	365HP*	\$12,551	TVC	365HP*	\$13,946	TVCS	7CME
30	2630	405HP*	\$14,717	TVC	405HP*	\$16,352	TVCS	7CME
40	3375	405HP*	\$16,949	TVC	405HP*	\$18,832	TVCS	7CME
50	3375	445HP	\$21,989	TVC	445HP	\$24,432	TVCS	7CME
60	2350	445HP	\$24,911	TVC	445HP	\$27,679	TVCS	7CME
75	2350	447HP	\$27,248	TVC	447HP	\$30,276	TVCS	7CME

& Standard Voltages Thru 405 Frame; 444 Frame & Larger, Single Voltage 460 or 575 standard

* Alternate "Z" Option Available for Shaft. See Dimension Pages for Detail

**Alternate C-Face and D-Flange Options Available on 449 and 5811 Frames

See Page M-84 For Available And Alternate BD Dimensions



Three Phase Modifiable Motors
Vertical C-Face
Corro-Duty
Totally Enclosed Fan Cooled (TEFC)
2 Pole, 3600 RPM



APPLICATIONS:

For use on Turbine, Mix Flow and Propeller Pumps

FEATURES:

- * Corro-Duty Construction (140-447 Frame)
- * Class F Insulation, Class B Rise at Full Load (Sine Wave Power)
- * 1.15 Service Factor (Sine Wave Power)
- * Maximum 40 Deg. C. Ambient, 3,300 Feet Altitude
- * NEMA Design "B"
- * 3 Phase 60 Hz
- * TS shaft (280 Frame & Larger) and D-flange also available

200, 230/460 575 Volts (&)

HP	Energy Efficient			Disc. Sym	Premium Efficient			Disc. Sym
	Frame	List	Type		Frame	List	Type	
1	143TC	\$1,012	FTCF	3FCM	143TC	\$1,077	TCEF	3CME
1.5	143TC	\$1,012	FTCF	3FCM	143TC	\$1,077	TCEF	3CME
2	145TC	\$1,122	FTCF	3FCM	145TC	\$1,199	TCEF	3CME
3	182TC	\$1,354	FTCF	3FCM	182TC	\$1,441	TCEF	3CME
5	184TC	\$1,552	FTCF	3FCM	184TC	\$1,661	TCEF	3CME
7.5	213TC	\$1,796	FTCF	3FCM	213TC	\$1,931	TCEF	3CME
10	215TC	\$2,004	FTCF	3FCM	215TC	\$2,162	TCEF	3CME
15	254TC	\$2,705	FTCF	3FCM	254TC	\$2,925	TCEF	3CME
20	256TC	\$3,177	FTCF	3FCM	256TC	\$3,449	TCEF	3CME
25	284TSC	\$3,882	FTCF	3FCM	284TSC	\$4,207	TCEF	3CME
30	286TSC	\$4,387	FTCF	3FCM	286TSC	\$4,768	TCEF	3CME
40	324TSC	\$5,631	FTCF	3FCM	324TSC	\$6,123	TCEF	3CME
50	326TSC	\$6,901	FTCF	3FCM	326TSC	\$7,534	TCEF	3CME
60	364TSC	\$9,175	FTCF	3FCM	364TSC	\$10,020	TCEF	3CME
75	365TSC	\$11,127	FTCF	3FCM	365TSC	\$12,189	TCEF	3CME
100	405TSC	\$14,955	FTCF	3FCM	405TSC	\$16,378	TCEF	3CME
125	444TSC	\$18,085	FTCF	3FCM	444TSC	\$19,822	TCEF	3CME
150	445TSC	\$21,691	FTCF	3FCM	445TSC	\$23,829	TCEF	3CME
200	447TSC	\$26,850	FTCF	3FCM	447TSC	\$29,552	TCEF	3CME

& Standard Voltages Thru 405 Frame; 444 Frame & Larger, Single Voltage 460 or 575 is Standard
 **Vertically Mounted C-face is a Horizontal Product Family Reference PB202 For Additional Pricing and Information

* 60Hz 3600, 1800, 1200 & 900 RPM motors comply with U.S. D.O.E.'s Efficiency regulation 10 CFR Section 431 Subpart B – electric motors (See Page M-80 - M-81 for Nominal Efficiency Table)



† All marks shown within this document are properties of their respective owners.

Three Phase Modifiable Motors
Vertical C-Face
Corro-Duty
Totally Enclosed Fan Cooled (TEFC)
4 Pole, 1800 RPM



APPLICATIONS:

For use on Turbine, Mix Flow and Propeller Pumps

FEATURES:

- * Corro-Duty Construction (140-447 Frame)
- * Class F Insulation, Class B Rise at Full Load (Sine Wave Power)
- * 1.15 Service Factor (Sine Wave Power)
- * Maximum 40 Deg. C. Ambient, 3,300 Feet Altitude
- * NEMA Design "B"
- * 3 Phase 60 Hz
- * TS shaft (280 Frame & Larger) and D-flange also available

200, 230/460 575 Volts (&)

HP	Energy Efficient			Disc. Sym	Premium Efficient			Disc. Sym
	Frame	List	Type		Frame	List	Type	
1	143TC	\$935	FTCF	3FCM	143TC	\$991	TCEF	3CME
1.5	143TC	\$990	FTCF	3FCM	143TC	\$1,052	TCEF	3CME
2	145TC	\$1,044	FTCF	3FCM	145TC	\$1,112	TCEF	3CME
3	182TC	\$1,263	FTCF	3FCM	182TC	\$1,340	TCEF	3CME
5	184TC	\$1,375	FTCF	3FCM	184TC	\$1,464	TCEF	3CME
7.5	213TC	\$1,680	FTCF	3FCM	213TC	\$1,802	TCEF	3CME
10	215TC	\$1,908	FTCF	3FCM	215TC	\$2,055	TCEF	3CME
15	254TC	\$2,506	FTCF	3FCM	254TC	\$2,704	TCEF	3CME
20	256TC	\$2,920	FTCF	3FCM	256TC	\$3,164	TCEF	3CME
25	284TC	\$3,520	FTCF	3FCM	284TC	\$3,804	TCEF	3CME
30	286TC	\$3,945	FTCF	3FCM	286TC	\$4,277	TCEF	3CME
40	324TC	\$5,100	FTCF	3FCM	324TC	\$5,533	TCEF	3CME
50	326TC	\$5,988	FTCF	3FCM	326TC	\$6,520	TCEF	3CME
60	364TC	\$8,527	FTCF	3FCM	364TC	\$9,300	TCEF	3CME
75	365TC	\$10,419	FTCF	3FCM	365TC	\$11,403	TCEF	3CME
100	405TC	\$13,061	FTCF	3FCM	405TC	\$14,273	TCEF	3CME
125	444TC	\$15,776	FTCF	3FCM	444TC	\$17,257	TCEF	3CME
150	445TC	\$18,268	FTCF	3FCM	445TC	\$20,025	TCEF	3CME
200	447TC	\$21,806	FTCF	3FCM	447TC	\$23,947	TCEF	3CME

& Standard Voltages Thru 405 Frame; 444 Frame & Larger, Single Voltage 460 or 575 is Standard
 **Vertically Mounted C-face is a Horizontal Product Family Reference PB202 For Additional Pricing and Information

* 60Hz 3600, 1800, 1200 & 900 RPM motors comply with U.S. D.O.E.'s Efficiency regulation 10 CFR Section 431 Subpart B – electric motors (See Page M-80 - M-81 for Nominal Efficiency Table)



Three Phase Modifiable Motors
Vertical C-Face
Corro-Duty
Totally Enclosed Fan Cooled (TEFC)
6 Pole, 1200 RPM



APPLICATIONS:

For use on Turbine, Mix Flow and Propeller Pumps

FEATURES:

- * Corro-Duty Construction (140-447 Frame)
- * Class F Insulation, Class B Rise at Full Load (Sine Wave Power)
- * 1.15 Service Factor (Sine Wave Power)
- * Maximum 40 Deg. C. Ambient, 3,300 Feet Altitude
- * NEMA Design "B"
- * 3 Phase 60 Hz
- * TS shaft (280 Frame & Larger) and D-flange also available

200, 230/460 575 Volts (&)

HP	Energy Efficient			Disc. Sym	Premium Efficient			Disc. Sym
	Frame	List	Type		Frame	List	Type	
1	145TC	\$1,117	FTCF	3FCM	145TC	\$1,193	TCEF	3CME
1.5	182TC	\$1,338	FTCF	3FCM	182TC	\$1,423	TCEF	3CME
2	184TC	\$1,425	FTCF	3FCM	184TC	\$1,519	TCEF	3CME
3	213TC	\$1,637	FTCF	3FCM	213TC	\$1,754	TCEF	3CME
5	215TC	\$2,092	FTCF	3FCM	215TC	\$2,259	TCEF	3CME
7.5	254TC	\$2,738	FTCF	3FCM	254TC	\$2,962	TCEF	3CME
10	256TC	\$3,156	FTCF	3FCM	256TC	\$3,426	TCEF	3CME
15	284TC	\$4,257	FTCF	3FCM	284TC	\$4,623	TCEF	3CME
20	286TC	\$4,954	FTCF	3FCM	286TC	\$5,398	TCEF	3CME
25	324TC	\$5,824	FTCF	3FCM	324TC	\$6,338	TCEF	3CME
30	326TC	\$6,656	FTCF	3FCM	326TC	\$7,262	TCEF	3CME
40	364TC	\$8,913	FTCF	3FCM	364TC	\$9,729	TCEF	3CME
50	365TC	\$10,031	FTCF	3FCM	365TC	\$10,971	TCEF	3CME
60	404TC	\$12,124	FTCF	3FCM	404TC	\$13,232	TCEF	3CME
75	405TC	\$13,910	FTCF	3FCM	405TC	\$15,216	TCEF	3CME
100	444TC	\$18,549	FTCF	3FCM	444TC	\$20,338	TCEF	3CME
125	445TC	\$20,521	FTCF	3FCM	445TC	\$22,529	TCEF	3CME
150	447TC	\$23,290	FTCF	3FCM	447TC	\$25,596	TCEF	3CME

& Standard Voltages Thru 405 Frame; 444 Frame & Larger, Single Voltage 460 or 575 is Standard
 **Vertically Mounted C-face is a Horizontal Product Family Reference PB202 For Additional Pricing and Information

* 60Hz 3600, 1800, 1200 & 900 RPM motors comply with U.S. D.O.E.'s Efficiency regulation 10 CFR Section 431 Subpart B – electric motors (See Page M-80 - M-81 for Nominal Efficiency Table)



Three Phase Modifiable Motors
Vertical C-Face
Corro-Duty
Totally Enclosed Fan Cooled (TEFC)
8 Pole, 900 RPM

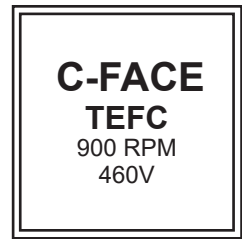

APPLICATIONS:

For use on Turbine, Mix Flow and Propeller Pumps

FEATURES:

- * Corro-Duty Construction (140-447 Frame)
- * Class F Insulation, Class B Rise at Full Load (Sine Wave Power)
- * 1.15 Service Factor (Sine Wave Power)
- * Maximum 40 Deg. C. Ambient, 3,300 Feet Altitude
- * NEMA Design "B"
- * 3 Phase 60 Hz
- * TS shaft (280 Frame & Larger) and D-flange also available

200, 230/460 575 Volts (&)

HP	Energy Efficient			Disc. Sym	Premium Efficient			Disc. Sym
	Frame	List	Type		Frame	List	Type	
1	182TC	\$1,637	FTCF	3FCM	182TC	\$1,759	TCEF	3CME
1.5	184TC	\$1,758	FTCF	3FCM	184 TC	\$1,889	TCEF	3CME
2	213TC	\$1,902	FTCF	3FCM	213TC	\$2,048	TCEF	3CME
3	215TC	\$2,217	FTCF	3FCM	215TC	\$2,399	TCEF	3CME
5	254TC	\$3,002	FTCF	3FCM	254TC	\$3,255	TCEF	3CME
7.5	256TC	\$3,762	FTCF	3FCM	256TC	\$4,100	TCEF	3CME
10	284TC	\$4,515	FTCF	3FCM	284TC	\$4,911	TCEF	3CME
15	286TC	\$5,714	FTCF	3FCM	286TC	\$6,243	TCEF	3CME
20	324TC	\$6,829	FTCF	3FCM	324TC	\$7,454	TCEF	3CME
25	326TC	\$7,868	FTCF	3FCM	326TC	\$8,609	TCEF	3CME
30	364TC	\$9,241	FTCF	3FCM	364TC	\$10,094	TCEF	3CME
40	365TC	\$11,074	FTCF	3FCM	365TC	\$12,130	TCEF	3CME
50	404TC	\$14,378	FTCF	3FCM	404TC	\$15,737	TCEF	3CME
60	405TC	\$16,261	FTCF	3FCM	405TC	\$17,829	TCEF	3CME
75	444TC	\$17,796	FTCF	3FCM	444TC	\$19,501	TCEF	3CME
100	445TC	\$24,138	FTCF	3FCM	445TC	\$26,548	TCEF	3CME
125	447TC	\$26,211	FTCF	3FCM	447TC	\$28,842	TCEF	3CME

& Standard Voltages Thru 405 Frame; 444 Frame & Larger, Single Voltage 460 or 575 is Standard
 **Vertically Mounted C-face is a Horizontal Product Family Reference PB202 For Additional Pricing and Information

* 60Hz 3600, 1800, 1200 & 900 RPM motors comply with U.S. D.O.E.'s Efficiency regulation 10 CFR Section 431 Subpart B – electric motors (See Page M-80 - M-81 for Nominal Efficiency Table)



Three Phase Modifiable Motors
Vertical C-Face
Corro-Duty
Totally Enclosed Fan Cooled (TEFC)
10 Pole, 720 RPM



APPLICATIONS:

For use on Turbine, Mix Flow and Propeller Pumps

FEATURES:

- * Corro-Duty Construction (140-447 Frame)
- * Class F Insulation, Class B Rise at Full Load (Sine Wave Power)
- * 1.15 Service Factor (Sine Wave Power)
- * Maximum 40 Deg. C. Ambient, 3,300 Feet Altitude
- * NEMA Design "B"
- * 3 Phase 60 Hz
- * TS shaft (280 Frame & Larger) and D-flange also available

200, 230/460 575 Volts (&)

HP	Energy Efficient			Disc. Sym	Premium Efficient			Disc. Sym
	Frame	List	Type		Frame	List	Type	
1	213TC	\$2,210	FTCF	3FCM	213TC	\$2,375	TCEF	3CME
1.5	213TC	\$2,373	FTCF	3FCM	213TC	\$2,550	TCEF	3CME
2	215TC	\$2,568	FTCF	3FCM	215TC	\$2,765	TCEF	3CME
3	254TC	\$2,993	FTCF	3FCM	254TC	\$3,239	TCEF	3CME
5	256TC	\$4,053	FTCF	3FCM	256TC	\$4,394	TCEF	3CME
7.5	284TC	\$5,079	FTCF	3FCM	284TC	\$5,535	TCEF	3CME
10	324TC	\$6,095	FTCF	3FCM	324TC	\$6,630	TCEF	3CME
15	326TC	\$7,714	FTCF	3FCM	326TC	\$8,428	TCEF	3CME
20	364TC	\$9,219	FTCF	3FCM	364TC	\$10,063	TCEF	3CME
25	365TC	\$10,622	FTCF	3FCM	365TC	\$11,622	TCEF	3CME
30	405TC	\$12,475	FTCF	3FCM	405TC	\$13,627	TCEF	3CME
40	405TC	\$14,950	FTCF	3FCM	405TC	\$16,376	TCEF	3CME
50	445TC	\$19,410	FTCF	3FCM	445TC	\$21,245	TCEF	3CME
60	445TC	\$21,952	FTCF	3FCM	445TC	\$24,069	TCEF	3CME
75	447TC	\$24,025	FTCF	3FCM	447TC	\$26,326	TCEF	3CME

& Standard Voltages Thru 405 Frame; 444 Frame & Larger, Single Voltage 460 or 575 is Standard
 **Vertically Mounted C-face is a Horizontal Product Family Reference PB202 For Additional Pricing and Information



**Three Phase Modifiable Motors
Vertical Solid Shaft / Hostile Duty
Normal Thrust - "P" Base
Totally Enclosed Fan Cooled (TEFC)
2 Pole, 3600 RPM**



APPLICATIONS:

For use on Turbine, Mix Flow and Propeller Pumps

FEATURES:

- * Hostile Duty Construction
- * Class F Insulation, Class B Rise at Full Load (Sine Wave Power)
- * 1.00 Service Factor (Sine Wave Power)
- * Maximum 40 Deg. C. Ambient, 3,300 Feet Altitude
- * NEMA Design "B"
- * 3 Phase 60 Hz
- * Both HP & VP Shaft Extension Available on 447 Frames and Smaller

200, 230/460 575 Volts (&)

HP	Down Thrust (lbs)	Energy Efficient			Premium Efficient			Disc. Sym
		Frame	List	Type	Frame	List	Type	
1	220	143HP	\$1,273	TVE	143HP	\$1,304	TVS	7ME
1.5	220	143HP	\$1,273	TVE	143HP	\$1,304	TVS	7ME
2	220	145HP	\$1,408	TVE	145HP	\$1,443	TVS	7ME
3	350	182HP	\$1,659	CTVE	182HP	\$1,742	CTVS	7ME
5	350	184HP	\$1,901	CTVE	184HP	\$1,996	CTVS	7ME
7.5	520	213HP	\$2,084	CTVE	213HP	\$2,194	CTVS	7ME
10	520	215HP	\$2,323	CTVE	215HP	\$2,445	CTVS	7ME
15	900	254HP	\$2,952	CTVE	254HP	\$3,107	CTVS	7ME
20	900	256HP	\$3,467	CTVE	256HP	\$3,649	CTVS	7ME
25	1050	284HP	\$4,325	CTVE	284HP	\$4,553	CTVS	7ME
30	1050	286HP	\$4,893	CTVE	286HP	\$5,151	CTVS	7ME
40	1090	324HP	\$6,459	CTVE	324HP	\$6,671	CTVS	7ME
50	1090	326HP	\$7,915	CTVE	326HP	\$8,188	CTVS	7ME
60	1360	364HP	\$10,524	CTVE	364HP	\$10,887	CTVS	7ME
75	1360	365HP	\$12,756	CTVE	365HP	\$13,212	CTVS	7ME
100	1825	405HP	\$17,151	CTVE	405HP	\$17,764	CTVS	7ME
125	1210	444HP	\$21,083	CTVE	444HP	\$21,844	CTVS	7ME
150	1210	445HP	\$25,296	CTVE	445HP	\$26,232	CTVS	7ME
200	1210	447HP	\$31,321	CTVE	447HP	\$32,505	CTVS	7ME

& Standard Voltages Thru 405 Frame; 444 Frame & Larger, Single Voltage 460 or 575 is Standard

*Alternate "Z" Option Available for Shaft. See Dimension Pages for Details

** Unimount Construction Available Up to 280 Frame

*** Hostile Duty construction is not available on 140 Frame

See Page M-84 For Available And Alternate BD Dimensions

* 60Hz 3600, 1800, 1200 & 900 RPM motors comply with U.S. D.O.E.'s Efficiency regulation 10 CFR Section 431 Subpart B – electric motors (See Page M-80 - M-81 for Nominal Efficiency Table)



Three Phase Modifiable Motors
Vertical Solid Shaft / Hostile Duty
Normal Thrust - "P" Base
Totally Enclosed Fan Cooled (TEFC)
4 Pole, 1800 RPM



APPLICATIONS:

For use on Turbine, Mix Flow and Propeller Pumps

FEATURES:

- * Hostile Duty Construction
- * Class F Insulation, Class B Rise at Full Load (Sine Wave Power)
- * 1.00 Service Factor (Sine Wave Power)
- * Maximum 40 Deg. C. Ambient, 3,300 Feet Altitude
- * NEMA Design "B"
- * 3 Phase 60 Hz
- * Both HP & VP Shaft Extension Available on 447 Frames and Smaller

200, 230/460 575 Volts (&)

HP	Down Thrust (lbs)	Energy Efficient			Premium Efficient			Disc. Sym
		Frame	List	Type	Frame	List	Type	
1	300	143HP	\$1,177	TVE	143HP	\$1,204	TVS	7ME
1.5	300	143HP	\$1,244	TVE	143HP	\$1,274	TVS	7ME
2	300	145HP	\$1,312	TVE	145HP	\$1,343	TVS	7ME
3	420	182HP	\$1,550	CTVE	182HP	\$1,627	CTVS	7ME
5	420	184HP	\$1,686	CTVE	184HP	\$1,770	CTVS	7ME
7.5	640	213HP	\$1,950	CTVE	213HP	\$2,053	CTVS	7ME
10	640	215HP	\$2,214	CTVE	215HP	\$2,330	CTVS	7ME
15	1110	254HP	\$2,734	CTVE	254HP	\$2,878	CTVS	7ME
20	1110	256HP	\$3,186	CTVE	256HP	\$3,354	CTVS	7ME
25	1380	284HP	\$3,918	CTVE	284HP	\$4,124	CTVS	7ME
30	1380	286HP	\$4,396	CTVE	286HP	\$4,627	CTVS	7ME
40	1395	324HP	\$5,851	CTVE	324HP	\$6,038	CTVS	7ME
50	1395	326HP	\$6,869	CTVE	326HP	\$7,098	CTVS	7ME
60	1800	364HP	\$9,781	CTVE	364HP	\$10,113	CTVS	7ME
75	1800	365HP	\$11,949	CTVE	365HP	\$12,373	CTVS	7ME
100	2300	405HP	\$14,981	CTVE	405HP	\$15,501	CTVS	7ME
125	1530	444HP	\$18,385	CTVE	444HP	\$19,034	CTVS	7ME
150	1530	445HP	\$21,295	CTVE	445HP	\$22,066	CTVS	7ME
200	1530	447HP	\$25,428	CTVE	447HP	\$26,366	CTVS	7ME

& Standard Voltages Thru 405 Frame; 444 Frame & Larger, Single Voltage 460 or 575 is Standard

*Alternate "Z" Option Available for Shaft. See Dimension Pages for Details

** Unimount Construction Available Up to 280 Frame

*** Hostile Duty construction is not available on 140 Frame

See Page M-84 For Available And Alternate BD Dimensions

* 60Hz 3600, 1800, 1200 & 900 RPM motors comply with U.S. D.O.E.'s Efficiency regulation 10 CFR Section 431 Subpart B – electric motors (See Page M-80 - M-81 for Nominal Efficiency Table)



**Three Phase Modifiable Motors
Vertical Solid Shaft / Hostile Duty
Normal Thrust - "P" Base
Totally Enclosed Fan Cooled (TEFC)
6 Pole, 1200 RPM**



APPLICATIONS:

For use on Turbine, Mix Flow and Propeller Pumps

FEATURES:

- * Hostile Duty Construction
- * Class F Insulation, Class B Rise at Full Load (Sine Wave Power)
- * 1.00 Service Factor (Sine Wave Power)
- * Maximum 40 Deg. C. Ambient, 3,300 Feet Altitude
- * NEMA Design "B"
- * 3 Phase 60 Hz
- * Both HP & VP Shaft Extension Available on 447 Frames and Smaller

200, 230/460 575 Volts (&)

HP	Down Thrust (lbs)	Energy Efficient			Premium Efficient			Disc. Sym
		Frame	List	Type	Frame	List	Type	
1	360	145HP	\$1,402	TVE	145HP	\$1,437	TVS	7ME
1.5	500	182HP	\$1,641	CTVE	182HP	\$1,723	CTVS	7ME
2	500	184HP	\$1,747	CTVE	184HP	\$1,834	CTVS	7ME
3	780	213HP	\$1,900	CTVE	213HP	\$2,000	CTVS	7ME
5	780	215HP	\$2,426	CTVE	215HP	\$2,554	CTVS	7ME
7.5	1350	254HP	\$3,173	CTVE	254HP	\$3,340	CTVS	7ME
10	1350	256HP	\$3,656	CTVE	256HP	\$3,848	CTVS	7ME
15	1570	284HP	\$4,646	CTVE	284HP	\$4,891	CTVS	7ME
20	1570	286HP	\$5,408	CTVE	286HP	\$5,692	CTVS	7ME
25	1750	324HP	\$6,972	CTVE	324HP	\$7,203	CTVS	7ME
30	1750	326HP	\$7,967	CTVE	326HP	\$8,240	CTVS	7ME
40	2200	364HP	\$10,225	CTVE	364HP	\$10,575	CTVS	7ME
50	2200	365HP	\$11,505	CTVE	365HP	\$11,910	CTVS	7ME
60	2825	404HP	\$13,906	CTVE	404HP	\$14,383	CTVS	7ME
75	2825	405HP	\$15,954	CTVE	405HP	\$16,515	CTVS	7ME
100	1930	444HP	\$25,178	CTVE	444HP	\$22,042	CTVS	7ME
125	1930	445HP	\$23,930	CTVE	445HP	\$24,809	CTVS	7ME
150	1930	447HP	\$27,162	CTVE	447HP	\$28,172	CTVS	7ME

& Standard Voltages Thru 405 Frame; 444 Frame & Larger, Single Voltage 460 or 575 is Standard

*Alternate "Z" Option Available for Shaft. See Dimension Pages for Details

** Unimount Construction Available Up to 280 Frame

*** Hostile Duty construction is not available on 140 Frame

See Page M-84 For Available And Alternate BD Dimensions

* 60Hz 3600, 1800, 1200 & 900 RPM motors comply with U.S. D.O.E.'s Efficiency regulation 10 CFR Section 431 Subpart B – electric motors (See Page M-80 - M-81 for Nominal Efficiency Table)



Three Phase Modifiable Motors
Vertical Solid Shaft / Hostile Duty
Normal Thrust - "P" Base
Totally Enclosed Fan Cooled (TEFC)
8 Pole, 900 RPM



APPLICATIONS:

For use on Turbine, Mix Flow and Propeller Pumps

FEATURES:

- * Hostile Duty Construction
- * Class F Insulation, Class B Rise at Full Load (Sine Wave Power)
- * 1.00 Service Factor (Sine Wave Power)
- * Maximum 40 Deg. C. Ambient, 3,300 Feet Altitude
- * NEMA Design "B"
- * 3 Phase 60 Hz
- * Both HP & VP Shaft Extension Available on 447 Frames and Smaller

200, 230/460 575 Volts (&)

HP	Down Thrust (lbs)	Energy Efficient			Premium Efficient			Disc. Sym
		Frame	List	Type	Frame	List	Type	
1	570	182HP	\$2,010	CTVE	182HP	\$2,110	CTVS	7ME
1.5	570	184HP	\$2,152	CTVE	184HP	\$2,260	CTVS	7ME
2	860	213HP	\$2,206	CTVE	213HP	\$2,322	CTVS	7ME
3	860	215HP	\$2,569	CTVE	215HP	\$2,705	CTVS	7ME
5	1540	254HP	\$3,550	CTVE	254HP	\$3,736	CTVS	7ME
7.5	1540	256HP	\$4,449	CTVE	256HP	\$4,684	CTVS	7ME
10	1740	284HP	\$5,459	CTVE	284HP	\$5,747	CTVS	7ME
15	1740	286HP	\$6,386	CTVE	286HP	\$6,722	CTVS	7ME
20	1945	324HP	\$8,173	CTVE	324HP	\$8,454	CTVS	7ME
25	1945	326HP	\$9,416	CTVE	326HP	\$9,749	CTVS	7ME
30	2515	364HP	\$11,061	CTVE	364HP	\$11,443	CTVS	7ME
40	2515	365HP	\$12,701	CTVE	365HP	\$13,154	CTVS	7ME
50	3230	404HP	\$16,491	CTVE	404HP	\$17,076	CTVS	7ME
60	3230	405HP	\$18,649	CTVE	405HP	\$19,323	CTVS	7ME
75	2240	444HP	\$20,747	CTVE	444HP	\$21,492	CTVS	7ME
100	2240	445HP	\$28,154	CTVE	445HP	\$29,210	CTVS	7ME
125	2240	447HP	\$30,574	CTVE	447HP	\$31,727	CTVS	7ME

& Standard Voltages Thru 405 Frame; 444 Frame & Larger, Single Voltage 460 or 575 is Standard

*Alternate "Z" Option Available for Shaft. See Dimension Pages for Details

** Unimount Construction Available Up to 280 Frame

*** Hostile Duty construction is not available on 140 Frame

See Page M-84 For Available And Alternate BD Dimensions

* 60Hz 3600, 1800, 1200 & 900 RPM motors comply with U.S. D.O.E.'s Efficiency regulation 10 CFR Section 431 Subpart B – electric motors (See Page M-80 - M-81 for Nominal Efficiency Table)



**Three Phase Modifiable Motors
Vertical Solid Shaft / Hostile Duty
Normal Thrust - "P" Base
Totally Enclosed Fan Cooled (TEFC)
10 Pole, 720 RPM**



APPLICATIONS:

For use on Turbine, Mix Flow and Propeller Pumps

FEATURES:

- * Hostile Duty Construction
- * Class F Insulation, Class B Rise at Full Load (Sine Wave Power)
- * 1.15 Service Factor (Sine Wave Power)
- * Maximum 40 Deg. C. Ambient, 3,300 Feet Altitude
- * NEMA Design "B"
- * 3 Phase 60 Hz
- * Both HP & VP Shaft Extension Available on 447 Frames and Smaller

200, 230/460 575 Volts (&)

HP	Down Thrust (lbs)	Standard Efficient			Premium Efficient			Disc. Sym
		Frame	List	Type	Frame	List	Type	
1	900	213HP	\$2,579	CTV	213HP	\$2,865	CTVS	7ME
1.5	900	213HP	\$2,761	CTV	213HP	\$3,068	CTVS	7ME
2	900	215HP	\$2,822	CTV	215HP	\$3,135	CTVS	7ME
3	1600	254HP	\$3,287	CTV	254HP	\$3,652	CTVS	7ME
5	1600	256HP	\$4,541	CTV	256HP	\$5,045	CTVS	7ME
7.5	1825	284HP*	\$5,692	CTV	284HP*	\$6,324	CTVS	7ME
10	1825	324HP	\$7,349	CTV	324HP	\$8,165	CTVS	7ME
15	2040	326HP	\$8,598	CTV	326HP	\$9,553	CTVS	7ME
20	2040	364HP*	\$10,273	CTV	364HP*	\$11,414	CTVS	7ME
25	2630	365HP*	\$11,845	CTV	365HP*	\$13,161	CTVS	7ME
30	2630	405HP*	\$13,903	CTV	405HP*	\$15,448	CTVS	7ME
40	3375	405HP*	\$15,983	CTV	405HP*	\$17,759	CTVS	7ME
50	3375	445HP	\$20,746	CTV	445HP	\$23,051	CTVS	7ME
60	2350	445HP	\$23,478	CTV	445HP	\$26,087	CTVS	7ME
75	2350	447HP	\$26,114	CTV	447HP	\$29,015	CTVS	7ME
100	2350	449VP	\$57,857	JV	449VP	\$66,536	JVE	9VM
125	2350	449VP	\$60,561	JV	449VP	\$69,645	JVE	9VM
150	2350	449VP	\$80,477	JV	449VP	\$92,549	JVE	9VM
200	2350	5807P	\$109,415	JV	5807P	\$125,827	JVE	9VM
250	2350	5809P	\$124,108	JV	5809P	\$142,724	JVE	9VM
300	2350	5809P	\$134,214	JV	5809P	\$154,346	JVE	9VM
350	2350	5811P	\$153,101	JV	5811P	\$176,066	JVE	9VM
400	2350	5811P	\$176,291	JV	5811P	\$202,735	JVE	9VM
450	2350	5812P	\$193,040	JV	5812P	\$221,996	JVE	9VM
500	2350	5812P	\$218,699	JV	5812P	\$251,504	JVE	9VM

& Standard Voltages Thru 405 Frame; 444 Frame & Larger, Single Voltage 460 or 575 standard

*Alternate "Z" Option Available for Shaft. See Dimension Pages for Detail

**Alternate C-Face and D-Flange Options Available on 449 and 5811 Frames

*** Unimount Construction Available Up to 280 Frame

**** Hostile Duty construction is not available on 140 Frame

See Page M-84 For Available And Alternate BD Dimensions



Three Phase Modifiable Motors
Vertical C-Face
Hostile Duty
Totally Enclosed Fan Cooled (TEFC)
2 Pole, 3600 RPM



APPLICATIONS:

For use on Turbine, Mix Flow and Propeller Pumps

FEATURES:

- * Hostile Duty Construction
- * Class F Insulation, Class B Rise at Full Load (Sine Wave Power)
- * 1.00 Service Factor (Sine Wave Power)
- * Maximum 40 Deg. C. Ambient, 3,300 Feet Altitude
- * NEMA Design "B"
- * 3 Phase 60 Hz
- * TS shaft on 280 Frame & Up and D-flange also available

200, 230/460 575 Volts (&)

HP	Energy Efficient			Disc. Sym	Premium Efficient			Disc. Sym
	Frame	List	Type		Frame	List	Type	
1	143TC	\$979	FCTF	3FM	143TC	\$1,002	CTEF	3ME
1.5	143TC	\$979	FCTF	3FM	143TC	\$1,002	CTEF	3ME
2	145TC	\$1,083	FCTF	3FM	145TC	\$1,110	CTEF	3ME
3	182TC	\$1,310	FCTF	3FM	182TC	\$1,341	CTEF	3ME
5	184TC	\$1,498	FCTF	3FM	184TC	\$1,536	CTEF	3ME
7.5	213TC	\$1,728	FCTF	3FM	213TC	\$1,776	CTEF	3ME
10	215TC	\$1,925	FCTF	3FM	215TC	\$1,981	CTEF	3ME
15	254TC	\$2,645	FCTF	3FM	254TC	\$2,725	CTEF	3ME
20	256TC	\$3,102	FCTF	3FM	256TC	\$3,201	CTEF	3ME
25	284TSC	\$3,874	FCTF	3FM	284TSC	\$3,995	CTEF	3ME
30	286TSC	\$4,377	FCTF	3FM	286TSC	\$4,519	CTEF	3ME
40	324TSC	\$5,617	FCTF	3FM	324TSC	\$5,801	CTEF	3ME
50	326TSC	\$6,883	FCTF	3FM	326TSC	\$7,120	CTEF	3ME
60	364TSC	\$9,151	FCTF	3FM	364TSC	\$9,467	CTEF	3ME
75	365TSC	\$11,092	FCTF	3FM	365TSC	\$11,489	CTEF	3ME
100	405TSC	\$14,915	FCTF	3FM	405TSC	\$15,447	CTEF	3ME
125	444TSC	\$18,333	FCTF	3FM	444TSC	\$18,995	CTEF	3ME
150	445TSC	\$21,997	FCTF	3FM	445TSC	\$22,811	CTEF	3ME
200	447TSC	\$27,236	FCTF	3FM	447TSC	\$28,265	CTEF	3ME

& Standard Voltages Thru 405 Frame; 444 Frame & Larger, Single Voltage 460 or 575 is Standard
 **Vertically Mounted C-face is a Horizontal Product Family Reference PB202 For Additional Pricing and Information

* 60Hz 3600, 1800, 1200 & 900 RPM motors comply with U.S. D.O.E.'s Efficiency regulation 10 CFR Section 431 Subpart B – electric motors (See Page M-80 - M-81 for Nominal Efficiency Table)



Three Phase Modifiable Motors
Vertical C-Face
Hostile Duty
Totally Enclosed Fan Cooled (TEFC)
4 Pole, 1800 RPM

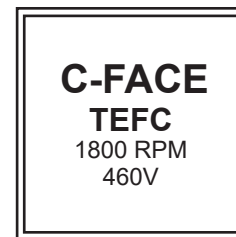

APPLICATIONS:

For use on Turbine, Mix Flow and Propeller Pumps

FEATURES:

- * Hostile Duty Construction
- * Class F Insulation, Class B Rise at Full Load (Sine Wave Power)
- * 1.00 Service Factor (Sine Wave Power)
- * Maximum 40 Deg. C. Ambient, 3,300 Feet Altitude
- * NEMA Design "B"
- * 3 Phase 60 Hz
- * TS shaft on 280 Frame & Up and D-flange also available

200, 230/460 575 Volts (&)

HP	Energy Efficient			Disc. Sym	Premium Efficient			Disc. Sym
	Frame	List	Type		Frame	List	Type	
1	143TC	\$906	FCTF	3FM	143TC	\$926	CTEF	3ME
1.5	143TC	\$958	FCTF	3FM	143TC	\$980	CTEF	3ME
2	145TC	\$1,009	FCTF	3FM	145TC	\$1,033	CTEF	3ME
3	182TC	\$1,225	FCTF	3FM	182TC	\$1,252	CTEF	3ME
5	184TC	\$1,330	FCTF	3FM	184TC	\$1,362	CTEF	3ME
7.5	213TC	\$1,619	FCTF	3FM	213TC	\$1,662	CTEF	3ME
10	215TC	\$1,834	FCTF	3FM	215TC	\$1,886	CTEF	3ME
15	254TC	\$2,452	FCTF	3FM	254TC	\$2,524	CTEF	3ME
20	256TC	\$2,853	FCTF	3FM	256TC	\$2,942	CTEF	3ME
25	284TC	\$3,512	FCTF	3FM	284TC	\$3,618	CTEF	3ME
30	286TC	\$3,936	FCTF	3FM	286TC	\$4,060	CTEF	3ME
40	324TC	\$5,088	FCTF	3FM	324TC	\$5,250	CTEF	3ME
50	326TC	\$5,973	FCTF	3FM	326TC	\$6,172	CTEF	3ME
60	364TC	\$8,505	FCTF	3FM	364TC	\$8,794	CTEF	3ME
75	365TC	\$10,391	FCTF	3FM	365TC	\$10,759	CTEF	3ME
100	405TC	\$13,027	FCTF	3FM	405TC	\$13,480	CTEF	3ME
125	444TC	\$15,988	FCTF	3FM	444TC	\$16,552	CTEF	3ME
150	445TC	\$18,518	FCTF	3FM	445TC	\$19,188	CTEF	3ME
200	447TC	\$22,111	FCTF	3FM	447TC	\$22,927	CTEF	3ME

& Standard Voltages Thru 405 Frame; 444 Frame & Larger, Single Voltage 460 or 575 is Standard
 **Vertically Mounted C-face is a Horizontal Product Family Reference PB202 For Additional Pricing and Information

* 60Hz 3600, 1800, 1200 & 900 RPM motors comply with U.S. D.O.E.'s Efficiency regulation 10 CFR Section 431 Subpart B – electric motors (See Page M-80 - M-81 for Nominal Efficiency Table)



Three Phase Modifiable Motors
Vertical C-Face
Hostile Duty
Totally Enclosed Fan Cooled (TEFC)
6 Pole, 1200 RPM



APPLICATIONS:

For use on Turbine, Mix Flow and Propeller Pumps

FEATURES:

- * Hostile Duty Construction
- * Class F Insulation, Class B Rise at Full Load (Sine Wave Power)
- * 1.00 Service Factor (Sine Wave Power)
- * Maximum 40 Deg. C. Ambient, 3,300 Feet Altitude
- * NEMA Design "B"
- * 3 Phase 60 Hz
- * TS shaft on 280 Frame & Up and D-flange also available

200, 230/460 575 Volts (&)

HP	Energy Efficient			Disc. Sym	Premium Efficient			Disc. Sym
	Frame	List	Type		Frame	List	Type	
1	145TC	\$1,078	FCTF	3FM	145TC	\$1,105	CTEF	3ME
1.5	182TC	\$1,295	FCTF	3FM	182TC	\$1,325	CTEF	3ME
2	184TC	\$1,377	FCTF	3FM	184TC	\$1,410	CTEF	3ME
3	213TC	\$1,579	FCTF	3FM	213TC	\$1,620	CTEF	3ME
5	215TC	\$2,008	FCTF	3FM	215TC	\$2,067	CTEF	3ME
7.5	254TC	\$2,626	FCTF	3FM	254TC	\$2,705	CTEF	3ME
10	256TC	\$3,020	FCTF	3FM	256TC	\$3,116	CTEF	3ME
15	284TC	\$4,157	FCTF	3FM	284TC	\$4,290	CTEF	3ME
20	286TC	\$4,833	FCTF	3FM	286TC	\$4,994	CTEF	3ME
25	324TC	\$5,810	FCTF	3FM	324TC	\$6,002	CTEF	3ME
30	326TC	\$6,639	FCTF	3FM	326TC	\$6,866	CTEF	3ME
40	364TC	\$8,891	FCTF	3FM	364TC	\$9,196	CTEF	3ME
50	365TC	\$10,004	FCTF	3FM	365TC	\$10,356	CTEF	3ME
60	404TC	\$12,093	FCTF	3FM	404TC	\$12,507	CTEF	3ME
75	405TC	\$13,873	FCTF	3FM	405TC	\$14,361	CTEF	3ME
100	444TC	\$18,499	FCTF	3FM	444TC	\$19,168	CTEF	3ME
125	445TC	\$20,808	FCTF	3FM	445TC	\$21,573	CTEF	3ME
150	447TC	\$23,619	FCTF	3FM	447TC	\$24,498	CTEF	3ME

& Standard Voltages Thru 405 Frame; 444 Frame & Larger, Single Voltage 460 or 575 is Standard
 **Vertically Mounted C-face is a Horizontal Product Family Reference PB202 For Additional Pricing and Information

* 60Hz 3600, 1800, 1200 & 900 RPM motors comply with U.S. D.O.E.'s Efficiency regulation 10 CFR Section 431 Subpart B – electric motors (See Page M-80 - M-81 for Nominal Efficiency Table)



Three Phase Modifiable Motors
Vertical C-Face
Hostile Duty
Totally Enclosed Fan Cooled (TEFC)
8 Pole, 900 RPM

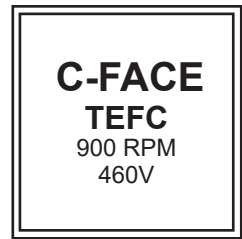

APPLICATIONS:

For use on Turbine, Mix Flow and Propeller Pumps

FEATURES:

- * Hostile Duty Construction
- * Class F Insulation, Class B Rise at Full Load (Sine Wave Power)
- * 1.00 Service Factor (Sine Wave Power)
- * Maximum 40 Deg. C. Ambient, 3,300 Feet Altitude
- * NEMA Design "B"
- * 3 Phase 60 Hz
- * TS shaft on 280 Frame & Up and D-flange also available

200, 230/460 575 Volts (&)

HP	Energy Efficient			Disc. Sym	Premium Efficient			Disc. Sym
	Frame	List	Type		Frame	List	Type	
1	182TC	\$1,581	FCTF	3FM	182TC	\$1,623	CTEF	3ME
1.5	184TC	\$1,691	FCTF	3FM	184TC	\$1,738	CTEF	3ME
2	213TC	\$1,828	FCTF	3FM	213TC	\$1,880	CTEF	3ME
3	215TC	\$2,126	FCTF	3FM	215TC	\$2,190	CTEF	3ME
5	254TC	\$2,933	FCTF	3FM	254TC	\$3,025	CTEF	3ME
7.5	256TC	\$3,670	FCTF	3FM	256TC	\$3,793	CTEF	3ME
10	284TC	\$4,504	FCTF	3FM	284TC	\$4,652	CTEF	3ME
15	286TC	\$5,699	FCTF	3FM	286TC	\$5,897	CTEF	3ME
20	324TC	\$6,811	FCTF	3FM	324TC	\$7,045	CTEF	3ME
25	326TC	\$7,847	FCTF	3FM	326TC	\$8,124	CTEF	3ME
30	364TC	\$9,217	FCTF	3FM	364TC	\$9,536	CTEF	3ME
40	365TC	\$11,044	FCTF	3FM	365TC	\$11,439	CTEF	3ME
50	404TC	\$14,340	FCTF	3FM	404TC	\$14,848	CTEF	3ME
60	405TC	\$16,217	FCTF	3FM	405TC	\$16,803	CTEF	3ME
75	444TC	\$18,040	FCTF	3FM	444TC	\$18,689	CTEF	3ME
100	445TC	\$24,482	FCTF	3FM	445TC	\$25,400	CTEF	3ME
125	447TC	\$26,587	FCTF	3FM	447TC	\$27,589	CTEF	3ME

& Standard Voltages Thru 405 Frame; 444 Frame & Larger, Single Voltage 460 or 575 is Standard
 **Vertically Mounted C-face is a Horizontal Product Family Reference PB202 For Additional Pricing and Information

* 60Hz 3600, 1800, 1200 & 900 RPM motors comply with U.S. D.O.E.'s Efficiency regulation 10 CFR Section 431 Subpart B – electric motors (See Page M-80 - M-81 for Nominal Efficiency Table)



Three Phase Modifiable Motors
Vertical C-Face
Hostile Duty
Totally Enclosed Fan Cooled (TEFC)
10 Pole, 720 RPM



APPLICATIONS:

For use on Turbine, Mix Flow and Propeller Pumps

FEATURES:

- * Hostile Duty Construction
- * Class F Insulation, Class B Rise at Full Load (Sine Wave Power)
- * 1.15 Service Factor (Sine Wave Power)
- * Maximum 40 Deg. C. Ambient, 3,300 Feet Altitude
- * NEMA Design "B"
- * 3 Phase 60 Hz
- * TS shaft on 280 Frame & Up and D-flange also available

200, 230/460 575 Volts (&)

HP	Energy Efficient			Disc. Sym	Premium Efficient			Disc. Sym
	Frame	List	Type		Frame	List	Type	
1	213TC	\$2,134	FCTF	3FM	213TC	\$2,191	CTEF	3ME
1.5	213TC	\$2,283	FCTF	3FM	213TC	\$2,346	CTEF	3ME
2	215TC	\$2,468	FCTF	3FM	215TC	\$2,538	CTEF	3ME
3	254TC	\$2,870	FCTF	3FM	254TC	\$2,957	CTEF	3ME
5	256TC	\$3,960	FCTF	3FM	256TC	\$4,084	CTEF	3ME
7.5	284TC	\$4,955	FCTF	3FM	284TC	\$5,121	CTEF	3ME
10	324TC	\$6,080	FCTF	3FM	324TC	\$6,280	CTEF	3ME
15	326TC	\$7,694	FCTF	3FM	326TC	\$7,961	CTEF	3ME
20	364TC	\$9,195	FCTF	3FM	364TC	\$9,511	CTEF	3ME
25	365TC	\$10,593	FCTF	3FM	365TC	\$10,967	CTEF	3ME
30	405TC	\$12,443	FCTF	3FM	405TC	\$12,874	CTEF	3ME
40	405TC	\$14,909	FCTF	3FM	405TC	\$15,443	CTEF	3ME
50	445TC	\$19,359	FCTF	3FM	445TC	\$20,045	CTEF	3ME
60	445TC	\$21,893	FCTF	3FM	445TC	\$22,684	CTEF	3ME
75	447TC	\$24,354	FCTF	3FM	447TC	\$25,230	CTEF	3ME

& Standard Voltages Thru 405 Frame; 444 Frame & Larger, Single Voltage 460 or 575 is Standard
 **Vertically Mounted C-face is a Horizontal Product Family Reference PB202 For Additional Pricing and Information



Three Phase Modifiable Motors
Vertical Solid Shaft / Meets IEEE Std 841™-2021
Normal Thrust - "P" Base
Totally Enclosed Fan Cooled (TEFC)
200, 230/460 575 Volts (&)



APPLICATIONS:

For use on Turbine, Mix Flow and Propeller Pumps

FEATURES:

- * Corro-Duty Construction
- * Class F Insulation, Class B Rise at Full Load (Sine Wave Power)
- * 1.15 Service Factor (Sine Wave Power)
- * Maximum 40 Deg. C. Ambient, 3,300 Feet Altitude
- * INPRO/SEAL®† on both ends
- * Special balance

- * Special shaft runout
- * NEMA Design "B"
- * 3 Phase 60 Hz
- * Both HP & VP Shaft Extension Available on 447 Frames and Smaller
- * Non-witnessed IEEE 841 Enhanced no load test
- * Grounding in terminal box and frame
- * Oversized main conduit box

3600 RPM

HP	Down Thrust+ (lbs)	Premium Efficient			Disc. Sym
		Frame	List	Type	
1	150	143HP	\$1,646	CEV	7CME
1.5	150	143HP	\$1,646	CEV	7CME
2	150	145HP	\$1,822	CEV	7CME
3	350	182HP	\$2,204	CEV	7CME
5	350	184HP	\$2,525	CEV	7CME
7.5	520	213HP	\$2,762	CEV	7CME
10	520	215HP	\$3,079	CEV	7CME
15	900	254HP	\$3,912	CEV	7CME
20	900	256HP	\$4,595	CEV	7CME
25	1050	284HP	\$5,734	CEV	7CME
30	1050	286HP	\$6,486	CEV	7CME
40	1090	324HP	\$8,098	CEV	7CME
50	1090	326HP	\$9,964	CEV	7CME
60	1360	364HP	\$13,251	CEV	7CME
75	1360	365HP	\$16,120	CEV	7CME
100	1825	405HP	\$21,659	CEV	7CME
125	1210	444HP	\$26,214	CEV	7CME
150	1210	445HP	\$31,513	CEV	7CME
200	1210	447HP	\$39,083	CEV	7CME

1800 RPM

HP	Down Thrust+ (lbs)	Premium Efficient			Disc. Sym
		Frame	List	Type	
1	200	143HP	\$1,520	CEV	7CME
1.5	200	143HP	\$1,608	CEV	7CME
2	200	145HP	\$1,695	CEV	7CME
3	420	182HP	\$2,058	CEV	7CME
5	420	184HP	\$2,239	CEV	7CME
7.5	640	213HP	\$2,585	CEV	7CME
10	640	215HP	\$2,934	CEV	7CME
15	1110	254HP	\$3,624	CEV	7CME
20	1110	256HP	\$4,224	CEV	7CME
25	1380	284HP	\$5,193	CEV	7CME
30	1380	286HP	\$5,827	CEV	7CME
40	1395	324HP	\$7,317	CEV	7CME
50	1395	326HP	\$8,623	CEV	7CME
60	1800	364HP	\$12,299	CEV	7CME
75	1800	365HP	\$15,080	CEV	7CME
100	2300	405HP	\$18,876	CEV	7CME
125	1530	444HP	\$22,822	CEV	7CME
150	1530	445HP	\$26,483	CEV	7CME
200	1530	447HP	\$31,670	CEV	7CME

& Standard Voltages Thru 405 Frame; 444 Frame & Larger, Single Voltage 460 or 575 is Standard

*Alternate "Z" Option Available for Shaft. See Dimension Pages for Details

+Minimum downthrust for 50,000 hours L-10 bearing life

See Page M-84 For Available And Alternate BD Dimensions

* 60Hz 3600, 1800, 1200 & 900 RPM motors comply with U.S. D.O.E.'s Efficiency regulation 10 CFR Section 431 Subpart B – electric motors (See Page M-80 - M-81 for Nominal Efficiency Table)



Three Phase Modifiable Motors
Vertical Solid Shaft / Meets IEEE Std 841™-2021
Normal Thrust - “P” Base
Totally Enclosed Fan Cooled (TEFC)
200, 230/460 575 Volts (&)



APPLICATIONS:

For use on Turbine, Mix Flow and Propeller Pumps

FEATURES:

- * Corro-Duty Construction
- * Class F Insulation, Class B Rise at Full Load (Sine Wave Power)
- * 1.15 Service Factor (Sine Wave Power)
- * Maximum 40 Deg. C. Ambient, 3,300 Feet Altitude
- * INPRO/SEAL®† on both ends
- * Special balance

- * Special shaft runout
- * NEMA Design “B”
- * 3 Phase 60 Hz
- * Both HP & VP Shaft Extension Available on 447 Frames and Smaller
- * Non-witnessed IEEE 841 Enhanced no load test
- * Grounding in terminal box and frame
- * Oversized main conduit box

1200 RPM

HP	Down Thrust + (lbs)	Premium Efficient			Disc. Sym
		Frame	List	Type	
1	240	145HP	\$1,814	CEV	7CME
1.5	500	182HP	\$2,180	CEV	7CME
2	500	184HP	\$2,320	CEV	7CME
3	780	213HP	\$2,519	CEV	7CME
5	780	215HP	\$3,217	CEV	7CME
7.5	1350	254HP	\$4,206	CEV	7CME
10	1350	256HP	\$4,846	CEV	7CME
15	1570	284HP*	\$6,159	CEV	7CME
20	1570	286HP*	\$7,168	CEV	7CME
25	1750	324HP	\$8,746	CEV	7CME
30	1750	326HP	\$10,021	CEV	7CME
40	2200	364HP*	\$12,866	CEV	7CME
50	2200	365HP*	\$14,508	CEV	7CME
60	2825	404HP*	\$17,500	CEV	7CME
75	2825	405HP*	\$20,123	CEV	7CME
100	1930	444HP	\$26,897	CEV	7CME
125	1930	445HP	\$29,795	CEV	7CME
150	1930	447HP	\$33,850	CEV	7CME

900 RPM

HP	Down Thrust+ (lbs)	Premium Efficient			Disc. Sym
		Frame	List	Type	
1	570	182HP	\$2,669	CEV	7CME
1.5	570	184HP	\$2,859	CEV	7CME
2	860	213HP	\$2,924	CEV	7CME
3	860	215HP	\$3,406	CEV	7CME
5	1540	254HP	\$4,705	CEV	7CME
7.5	1540	256HP	\$5,898	CEV	7CME
10	1740	284HP	\$7,237	CEV	7CME
15	1740	286HP	\$8,465	CEV	7CME
20	1945	324HP	\$10,287	CEV	7CME
25	1945	326HP	\$11,880	CEV	7CME
30	2515	364HP	\$13,930	CEV	7CME
40	2515	365HP	\$16,040	CEV	7CME
50	3230	404HP	\$20,812	CEV	7CME
60	3230	405HP	\$23,580	CEV	7CME
75	3230	444HP	\$25,790	CEV	7CME
100	3230	445HP	\$35,110	CEV	7CME
125	3230	447HP	\$38,143	CEV	7CME

& Standard Voltages Thru 405 Frame; 444 Frame & Larger, Single Voltage 460 or 575 is Standard

*Alternate “Z” Option Available for Shaft. See Dimension Pages for Details

+Minimum downthrust for 50,000 hours L-10 bearing life

See Page M-84 For Available And Alternate BD Dimensions

* 60Hz 3600, 1800, 1200 & 900 RPM motors comply with U.S. D.O.E.’s Efficiency regulation 10 CFR Section 431 Subpart B – electric motors (See Page M-80 - M-81 for Nominal Efficiency Table)



Three Phase Modifiable Motors
Vertical C-Face
Meets IEEE Std 841™-2021
Totally Enclosed Fan Cooled (TEFC)
200, 230/460 575 Volts (&)

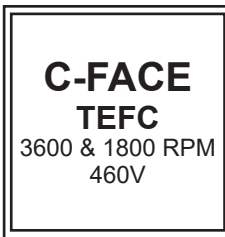

APPLICATIONS:

For use on Turbine, Mix Flow and Propeller Pumps

FEATURES:

- * Corro-Duty Construction
- * Class F Insulation, Class B Rise at Full Load (Sine Wave Power)
- * 1.15 Service Factor (Sine Wave Power)
- * Maximum 40 Deg. C. Ambient, 3,300 Feet Altitude
- * INPRO/SEAL®† on both ends

- * Special balance
- * Special shaft runout
- * NEMA Design "B"
- * 3 Phase 60 Hz
- * Non-witnessed IEEE 841 Enhanced no load test
- * Grounding in terminal box and frame
- * Oversized main conduit box
- * TS shaft on 280 Frame & Up and D-flange also available

3600 RPM

HP	Premium Efficient			Disc. Sym
	Frame	List	Type	
1	143TC	\$1,306	CEF	841M
1.5	143TC	\$1,306	CEF	841M
2	145TC	\$1,454	CEF	841M
3	182TC	\$1,673	CEF	841M
5	184TC	\$1,941	CEF	841M
7.5	213TC	\$2,173	CEF	841M
10	215TC	\$2,433	CEF	841M
15	254TC	\$3,291	CEF	841M
20	256TC	\$4,012	CEF	841M
25	284TSC	\$4,666	CEF	841M
30	286TSC	\$5,202	CEF	841M
40	324TSC	\$6,800	CEF	841M
50	326TSC	\$8,404	CEF	841M
60	364TSC	\$10,982	CEF	841M
75	365TSC	\$13,163	CEF	841M
100	405TSC	\$17,914	CEF	841M
125	444TSC	\$22,147	CEF	841M
150	445TSC	\$26,958	CEF	841M
200	447TSC	\$32,226	CEF	841M

1800 RPM

HP	Premium Efficient			Disc. Sym
	Frame	List	Type	
1	143TC	\$1,216	CEF	841M
1.5	143TC	\$1,272	CEF	841M
2	145TC	\$1,338	CEF	841M
3	182TC	\$1,545	CEF	841M
5	184TC	\$1,693	CEF	841M
7.5	213TC	\$2,021	CEF	841M
10	215TC	\$2,308	CEF	841M
15	254TC	\$3,033	CEF	841M
20	256TC	\$3,669	CEF	841M
25	284TC	\$4,206	CEF	841M
30	286TC	\$4,655	CEF	841M
40	324TC	\$6,129	CEF	841M
50	326TC	\$7,251	CEF	841M
60	364TC	\$10,180	CEF	841M
75	365TC	\$12,305	CEF	841M
100	405TC	\$15,582	CEF	841M
125	444TC	\$19,239	CEF	841M
150	445TC	\$22,597	CEF	841M
200	447TC	\$27,416	CEF	841M

* 60Hz 3600, 1800, 1200 & 900 RPM motors comply with U.S. D.O.E.'s Efficiency regulation 10 CFR Section 431 Subpart B – electric motors (See Page M-80 - M-81 for Nominal Efficiency Table)



† All marks shown within this document are properties of their respective owners.

Three Phase Modifiable Motors
Vertical C-Face
Meets IEEE Std 841™-2021
Totally Enclosed Fan Cooled (TEFC)
200, 230/460 575 Volts (&)



APPLICATIONS:

For use on Turbine, Mix Flow and Propeller Pumps

FEATURES:

- * Corro-Duty Construction
- * Class F Insulation, Class B Rise at Full Load (Sine Wave Power)
- * 1.15 Service Factor (Sine Wave Power)
- * Maximum 40 Deg. C. Ambient, 3,300 Feet Altitude
- * INPRO/SEAL^{®†} on both ends

- * Special balance
- * Special shaft runout
- * NEMA Design "B"
- * 3 Phase 60 Hz
- * Non-witnessed IEEE 841 Enhanced no load test
- * Grounding in terminal box and frame
- * Oversized main conduit box
- * TS shaft on 280 Frame & Up and D-flange also available

1200 RPM

HP	Premium Efficient			Disc. Sym
	Frame	List	Type	
1	145TC	\$1,499	CEF	841M
1.5	182TC	\$1,722	CEF	841M
2	184TC	\$1,831	CEF	841M
3	213TC	\$2,067	CEF	841M
5	215TC	\$2,690	CEF	841M
7.5	254TC	\$3,364	CEF	841M
10	256TC	\$3,890	CEF	841M
15	284TC	\$5,232	CEF	841M
20	286TC	\$6,316	CEF	841M
25	324TC	\$7,064	CEF	841M
30	326TC	\$7,952	CEF	841M
40	364TC	\$10,852	CEF	841M
50	365TC	\$12,264	CEF	841M
60	404TC	\$14,493	CEF	841M
75	405TC	\$16,414	CEF	841M
100	444TC	\$22,270	CEF	841M
125	445TC	\$25,217	CEF	841M
150	447TC	\$28,971	CEF	841M

900 RPM

HP	Premium Efficient			Disc. Sym
	Frame	List	Type	
1	182TC	\$2,231	CEF	841M
1.5	184TC	\$2,355	CEF	841M
2	213TC	\$2,528	CEF	841M
3	215TC	\$2,881	CEF	841M
5	254TC	\$3,991	CEF	841M
7.5	256TC	\$4,805	CEF	841M
10	284TC	\$5,834	CEF	841M
15	286TC	\$7,280	CEF	841M
20	324TC	\$8,974	CEF	841M
25	326TC	\$9,647	CEF	841M
30	364TC	\$11,050	CEF	841M
40	365TC	\$13,611	CEF	841M
50	404TC	\$17,641	CEF	841M
60	405TC	\$19,587	CEF	841M
75	444TC	\$21,775	CEF	841M
100	445TC	\$29,761	CEF	841M
125	447TC	\$32,349	CEF	841M

* 60Hz 3600, 1800, 1200 & 900 RPM motors comply with U.S. D.O.E.'s Efficiency regulation 10 CFR Section 431 Subpart B – electric motors (See Page M-80 - M-81 for Nominal Efficiency Table)



NEMA VERTICAL QUICK PICK MODIFIABLE MOTORS



ITEM	PG.	NOTE	DESCRIPTION	FRAME SIZE							
				182 184	213 215	254 256	284 286	324 326	364 365	404 405	444 447
1	M-4		Aerator Duty	Add 15% to N. Thrust List							
2	M-4	(1)	Altitude (≤9900 ft)	\$164	\$197	\$261	\$434	\$570	\$732	\$1,063	\$1,498
3	M-5	(1)	Ambient (≤65°C)	\$164	\$197	\$261	\$434	\$570	\$732	\$1,063	\$1,498
3A	M-5		Arctic Duty	Add 25% to TEFC							
4	M-6		Balance - Normal Thrust	\$141	\$141	\$141	\$141	\$202	\$202	\$202	\$202
			Balance - High Thrust	\$282	\$282	\$282	\$282	\$404	\$404	\$404	\$404
6	M-10 M-11		Bearings								
			- 175% EHT	N/A	N/A	N/A	N/A	4%	4%	4%	4%
			- 300% EHT	N/A	N/A	N/A	N/A	N/A	N/A	N/A	7.5%
			- Insulated (Upper)	\$550	\$850	\$1,200	\$1,500	\$1,500	\$1,500	\$1,500	\$1,500
		- Insulated (Both)	\$1,100	\$1,700	\$2,400	\$3,000	\$3,000	\$3,000	\$3,000	\$3,000	
8	M-12 M-13 M-14		Conduit Box - Accessory	N/A				\$901	\$901	\$901	\$901
			- Cast Iron	Use CORRO-DUTY®				\$293	\$469	\$587	\$704
			- Oversize	\$178	\$178	\$178	\$178	\$178	\$178	\$178	\$704
			- NEMA® 4X Epoxy Coated	\$352	\$469	\$587	\$704	\$822	\$939	\$1,056	\$1,174
			- Ground Lug In OB	\$108	\$108	\$108	\$108	\$108	\$108	\$108	\$108
11	M-21		Drain & Br. - TEFC	\$178	\$178	\$178	\$418	\$418	\$418	\$418	\$418
			- Hazardous Location	\$270	\$270	\$270	\$634	\$634	\$634	\$634	\$634
13	M-26 M-27		CORRO-DUTY®	Add 10% to Base TEFC							
			841 PLUS® Modifications	\$1,000	\$1,500	\$2,000	\$2,500	\$3,900	\$4,734	\$5,666	See Page M-27
13H	M-26		Heavy Duty TEFC	Add 5% to Base TEFC List							
14	M-28		Export Boxing	6% But Not Less Than \$150 Net							
15	M-29	(1)	Frequency - 50Hz	Add 10% to Base 60 Hz List to Keep STD S.F.							
18	M-30 M-32		- Insulation - Class H	\$175	\$211	\$277	\$462	\$607	\$779	\$1,125	See Page M-30
			- INS 2000	\$80	\$127	\$162	\$270	\$345	\$425	\$570	\$742
			- VPI 1000	Not Available				\$1,714	\$2,019	\$2,847	\$3,887
			- VPI 2000	Not Available				\$3,427	\$4,038	\$5,695	\$7,775
			- Abrasion Resist	\$80	\$127	\$162	\$270	\$345	\$425	\$570	\$742
19	M-34	(1)	Inverter Duty	Premium Efficiency Base List Add 7.5%							
22	M-35	(1)	Multispeed	For Constant Torque See Mod. Section							
		(1)	- Var TQ 2 SP/1WDG	45%							
		(1)	- Var TQ 2 SP/2WDG	130%							
23	M-37		Special Nameplate	\$340	\$340	\$340	\$340	\$340	\$340	\$340	\$340
			Rotational Arrow	\$47	\$47	\$47	\$47	\$47	\$47	\$47	\$47
26	M-40		Oil Sump Heaters	N/A	N/A	N/A	N/A	\$469	\$469	\$563	\$563

NOTE: This is a condensed version of the complete modification section used to qualify the availability of these options.

- (1) Will likely change performance characteristics and/or frame size of certain product.
- (2) Add thermal protection (thermostats, etc.) per item 50 if required by customer.



† All marks shown within this document are properties of their respective owners.

NEMA VERTICAL QUICK PICK MODIFIABLE MOTORS



ITEM	PG.	NOTE	DESCRIPTION	FRAME SIZE								
				182 184	213 215	254 256	284 286	324 326	364 365	404 405	444 447	
29	M-42		Paint - Primer Only Special Paint	No Charge for STD Primer Only								
				\$352	\$469	\$587	\$704	\$822	\$939	\$1,056	\$1,174	
35	M-48		Stainless Steel Screens	\$469	\$469	\$469	\$528	\$763	\$1,115	\$1,115	\$1,761	
36	M-48		Seals - Shaft Slinger	\$141	\$141	\$200	\$200	\$270	\$270	\$340	\$376	
			- Lip Seal	\$141	\$200	\$200	\$200	\$270	\$270	\$340	See Page M-48	
			- INPRO/SEAL [†]	\$352	\$352	\$587	\$822	\$822	\$1,056	\$1,291	See Page M-48	
			- INPRO/SEAL [†] - MGS	\$1,056	\$1,056	\$1,761	\$2,466	\$2,466	\$3,168	\$3,873	See Page M-48	
37	M-49	(1),(2)	Service Factor	\$352	\$469	\$587	\$728	\$939	\$1,878	\$2,559	\$3,150	
38	M-50	(2)	Shaft Ground Ring - AEGIS [†] SGR [†]	\$350	\$350	\$510	\$550	\$710	\$710	\$1,115	\$1,291	
			INPRO/SEAL [†] CDR [†]	\$350	\$350	\$510	\$550	\$710	\$710	\$1,115	\$1,291	
40	M-51		Space Heater TEFC / WPI	\$300	\$300	\$300	\$300	\$385	\$385	\$385	\$385	
			Space Heater Haz. Loc.	\$601	\$601	\$601	\$601	\$770	\$770	\$770	\$770	
42	M-53		Stainless Steel Hardware	\$282	\$282	\$282	\$282	\$528	\$528	\$528	\$528	
43B	M-55		Connection-PWS	N/A	N/A	\$99	\$131	\$202	\$291	\$451	N/C	
			- WYE Delta	\$99	\$99	\$99	\$131	\$202	\$291	\$451	N/C	
44	M-59		Bushings - Steady	\$202	\$202	\$202	\$202	\$300	\$300	\$300	\$300	
46	M-62		Temp Rise - Class B @ 1.15 SF	\$164	\$469	\$469	\$728	\$939	\$1,878	\$2,559	\$3,521	
			- Class A	Price as Premium Efficiency Plus 7%								
48	M-65		- Testing - S.C.T.	\$235	\$235	\$235	\$235	\$235	\$235	\$235	\$235	
			- Witnessed S.C.T	\$675	\$675	\$675	\$675	\$675	\$675	\$675	\$675	
			- Complete I. Test	\$1,385	\$1,385	\$1,385	\$1,385	\$2,136	\$2,770	\$3,263	\$4,531	
			- Witnessed C.I.T.	\$2,113	\$2,113	\$2,113	\$2,113	\$3,263	\$4,155	\$4,906	\$6,784	
			- Noise Test	\$1,502	\$1,502	\$1,502	\$1,502	\$1,502	\$1,878	\$2,113	\$2,347	
			- Witnessed Noise	\$2,254	\$2,254	\$2,254	\$2,254	\$2,254	\$2,817	\$3,169	\$3,521	
49	M-69		Bearing RTD 10 or 120 ohm	Not Available			\$1,340	\$1,340	\$1,340	\$1,340		
			Bearing RTD 100 ohm - Std.	Not Available			\$2,150	\$2,150	\$2,150	\$2,150		
49B	M-70 M-71 M-72 M-73		Winding Thermostats	\$89	\$89	\$89	\$146	\$207	\$308	\$308	\$308	
			THERMA SENTRY [®] SMSE	\$1,410	\$1,410	\$1,410	\$1,410	\$1,410	\$1,410	\$1,410	\$1,410	
			THERMA SENTRY [®] MMSE	Not Available							\$2,880	\$2,880
			Winding Thermistors	\$472	\$472	\$472	\$669	\$669	\$876	\$876	\$876	
			Winding RTD 10 or 120 ohm	Not Available			\$2,545	\$2,545	\$2,545	\$2,545		
			Winding RTD 100 ohm - Std.	Not Available			\$3,825	\$3,825	\$3,825	\$3,825		
50	M-74 M-75		Special Mounting Tolerance	\$704	\$704	\$704	\$704	\$939	\$1,232	\$1,408	\$1,761	
			API-610 Tolerances	\$939	\$939	\$939	\$939	\$1,291	\$1,643	\$1,878	\$2,347	
53	M-78	(1)	Voltage Special	600 Volts or Less Add 4% to List								

NOTE: This is a condensed version of the complete modification section used to qualify the availability of these options.
 (1) Will likely change performance characteristics and/or frame size of certain products.

(2) Refer to page M-49 item 38 for details of this price adder.
 (3) WPI Only



† All marks shown within this document are properties of their respective owners.

TITAN® VERTICAL QUICK PICK MODIFIABLE MOTORS



ITEM	PG.	NOTE	DESCRIPTION	FRAME SIZE LIST PRICE ADDER					
				449	5000	5800	6812 (TE)	6800-8000	9600
2	M-4	(1)	Altitude (≤9900 ft)	\$4,068	6%	6%	6%	6%	6%
3	M-5	(1)	Ambient (≤65°C) O/E	\$4,068	12%/6%	12% / 6%	12%	15%	15%
4	M-6		Balance Special	\$1,467	\$1,467	\$4,354	\$4,354	\$5,444	\$5,444
5	M-7	(1), (3)	Base Diameters	\$3,756	\$3,756	\$5,634	\$7,518	See Page 114	
6	M-11 M-10	(1), (2), (3)	Bearings - Spare set	Add 7% to Base List Price					
			- 175% EHT	4%	4%	4%	4%	4%	4%
			- 300% EHT	7.5%	7.5%	7.5%	7.5%	7.5%	7.5%
			- Insulated (Upper only)	\$1,800	N/C	N/C	N/C	N/C	N/C
			- Insulated (both)	\$3,600	\$2,400	\$2,400	\$3,000	\$3,000	\$3,000
			- Water cooling coils	5% / 7.5% When Not Standard					
7	M-12		Buss Bar	\$4,178	\$4,178	\$4,178	\$4,178	\$4,178	\$4,178
8	M-15 M-16 M-17 M-18 M-19		Conduit Box - Accessory	\$1,127	\$1,127	\$1,127	\$1,127	\$1,127	\$1,127
			- Ground Lug or Servit Post	\$164	\$164	\$164	\$164	\$164	\$164
			- Lead Positioning Gasket	\$223	\$223	\$223	\$223	\$223	\$223
			- NEMA Type II	See Page M-18					
			- Oversized	See Page M-16					
10	M-20		Current Transformer	See Page M-20					
11	M-21		Drain & Breather - TEFC	\$178	\$178	\$178	\$178	N/A	N/A
			- Hazardous Location	\$270	\$270	\$270	N/A	N/A	N/A
13	M-26 M-27		CORRO-DUTY® - Basic	6%	6%	6%	N/A	N/A	N/A
			Basic Plus Cast Iron Fan Guard	8%	8%	8%	N/A	N/A	N/A
			841 PLUS® Modifications	\$11,620	\$12,290	\$13,238	N/A	N/A	N/A
13B	M-24 M-25	(1)	Enclosure - WPII	\$15,365	\$17,606	\$26,408	N/A	\$41,815	\$52,230
			- Air Filters (Std.)	\$2,507	\$2,507	\$2,507	\$2,507	\$2,507	\$2,507
			- Air Press. Diff. Switch	\$1,676	\$1,676	\$1,676	\$1,676	\$1,676	\$1,676
			- Air Temp. Sensor	\$1,897	\$1,897	\$1,897	\$1,897	\$1,897	\$1,897
14	M-28	(3)	Export Boxing	3% But Not Less Than \$150 Net					
15	M-29	(1)	Frequency - 50Hz	Add 10% to Base 60Hz List to Keep STD S.F.					
16	M-29		Ground Pad	\$441	\$441	\$441	\$441	\$441	\$441
			- Hazardous Location	\$549	\$549	\$549	N/A	N/A	N/A
18	M-32		Insulation - Class H	\$1,855	\$2,356	\$3,031	\$4,914	\$5,859	\$6,359
			- EVERSEAL® WPI, WPII / TEFC	5/2.5%	5/3%	5/3%	N/A / 5%	5% / N/A	5% / N/A
			- Abrasion Resistant	1%	1%	1%	1%	1%	1%
			- Insulife VPI 2000	3%	3%	3%	N/A	N/A	N/A
19	M-35		Inverter Duty	Premium Efficiency Base List Add 5%					
23	M-37		Nameplate - Special	\$340	\$340	\$340	\$340	\$340	\$340
			Rotation Arrow	\$47	\$47	\$47	\$47	\$47	\$47

NOTE: This is a condensed version of the complete modification section used to qualify the availability of these options.

- (1) Will likely change performance characteristics and/or frame size of certain product.
- (2) Refer to main Mod Section for details.
- (3) Extends Delivery.



† All marks shown within this document are properties of their respective owners.

**TITAN® VERTICAL QUICK PICK
MODIFIABLE MOTORS**



ITEM	PG.	NOTE	DESCRIPTION	FRAME SIZE LIST PRICE ADDER					
				449	5000	5800	6812 (TE)	6800-8000	9600
26	M-40	(2)	Oil Sump Heater - STD	\$2,202	\$2,202	\$2,495	\$2,789	\$2,934	\$3,110
29	M-42		Paint - Special	\$1,878	\$1,878	\$3,756	\$5,634	\$5,634	\$5,634
34	M-47	(1)	Rotor - Copper Bar - 4 Pole	\$32,277	\$32,277	\$35,211	\$37,559	\$39,906	\$42,254
35	M-48		Stainless Steel Screens	\$1,761	\$1,761	\$1,761	N/A	\$2,200	\$2,495
36	M-48		Seals - Shaft Slinger	\$469	\$469	\$469	\$469	\$469	\$469
			- Lip Seal	\$469	N/A	N/A	N/A	N/A	N/A
			- INPRO/SEAL®†	\$1,937	\$3,815	\$3,815	\$3,815	\$3,815	\$3,815
			- INPRO/SEAL®†-MGS	\$5,811	\$11,445	\$11,445	\$11,445	\$11,445	\$11,445
37	M-49	(1)	Service Factor	\$4,432	5%	5%	6%	6%	6%
38	M-50	(2)	Shaft Ground Ring - AEGIS®† SGR®†	\$1,937	\$3,815	\$3,815	\$3,815	\$3,815	\$3,815
			INPRO/SEAL®† CDR®†	\$1,937	\$3,815	\$3,815	\$3,815	\$3,815	\$3,815
40	M-51	(4)	Space Heater - WPI/TEFC	\$1,657	\$1,657	\$1,819	\$2,789	\$2,789	\$2,789
			- Hazardous Location	\$3,317	\$3,317	\$3,638	\$5,575	\$5,575	\$5,575
42	M-53		Stainless Steel Hardware	\$547	\$547	\$547	\$573	\$735	\$735
44	M-59		Bushing - Steady	\$523	\$523	\$523	\$523	\$2,202	\$2,202
45	M-62		Surge Protection - 460V	\$8,554	\$8,554	\$8,554	\$8,554	\$8,554	\$8,554
			- 2300V	\$21,568	\$21,568	\$21,568	\$21,568	\$21,568	\$21,568
			- 4160V	\$28,317	\$28,317	\$28,317	\$28,317	\$28,317	\$28,317
			- 6600V	\$36,796	\$36,796	\$36,796	\$36,796	\$36,796	\$36,796
46	M-64	(1),(2)	Temp Rise - Class B @ 1.15 S.F.	\$5,664	12%	12%	12%	12%	12%
48	M-66	(3)	Testing - S.C.T.	\$235	\$235	\$235	\$235	\$235	\$235
			- Witnessed S.C.T.	\$675	\$675	\$1,000	\$1,350	\$1,350	\$1,350
			- Complete Initial Test	\$8,350	\$8,350	\$8,350	\$11,700	\$11,700	\$11,700
			- Witnessed C.I.T.	\$16,700	\$16,700	\$16,700	\$23,350	\$23,350	\$23,350
			- Noise	\$2,347	\$2,347	\$3,852	\$4,270	\$4,270	\$5,129
			- Witnessed Noise	\$3,521	\$3,521	\$6,406	\$6,406	\$6,406	\$7,981
49	M-69		- Bearing Thermocouple	\$590 One Bearing / \$1,180 Two Bearings					
			- Bearing Temp. Switch	\$590 One Bearing / \$1,180 Two Bearings					
			- Bearing Temp. Indicator	\$1,340 One Bearing / \$2,680 Two Bearings					
			- Bearing Stem Type Thermometer	\$1,340 One Bearing / \$2,680 Two Bearings					
			- Bearing RTD 10 or 120 ohm	\$1,340 One Bearing / \$2,680 Two Bearings					
			- Bearing RTD 100 ohm - Std.	\$2,150 One Bearing / \$4,300 Two Bearings					
49B	M-70 M-71 M-72 M-73		Winding Thermostats	\$408	\$408	\$725	\$725	\$725	\$725
			Winding Thermistors (No Control)	\$1,303	\$1,303	\$1,303	\$1,303	\$1,303	\$1,303
			THERMA SENTRY® SMSE	\$1,755	\$1,755	\$1,755	\$1,755	\$1,755	\$1,755
			THERMA SENTRY® MMSE	\$2,880	\$2,880	\$2,880	\$2,880	\$2,880	\$2,880
			Winding Thermocouple	\$3,440	\$3,440	\$3,440	\$3,440	\$3,440	\$3,440
			Winding RTD 10 or 120 ohm	\$3,440	\$3,440	\$3,440	\$3,440	\$3,440	\$3,440
			Winding RTD 100 ohm - Std.	\$5,165	\$5,165	\$5,165	\$5,165	\$5,165	\$5,165
50	M-74 M-75		Special Mounting Tolerance	\$3,521	\$3,521	\$4,401	\$5,282	\$7,512	\$7,512
			- API-610 Tolerance	\$4,695	\$4,695	\$5,869	\$7,042	\$9,977	\$9,977

NOTE: This is a condensed version of the complete modification section used to qualify the availability of these options.
 (1) This option will likely change performance characteristics and/or frame size of certain products.
 (2) Refer to main Mod. Section for detailed explanation or proper price application.
 (3) Extends Delivery.



† All marks shown within this document are properties of their respective owners.

WE BUILD MORE THAN JUST MOTORS.
WE BUILD SOLUTIONS.



When your irrigation application requires a single speed solution, the SINEWAVE OPTIMIZED™ line of U.S. MOTORS® brand NEMA Premium® Efficient vertical pump motors offers high quality at a low cost, with the same construction and reliability you've come to expect from our brand. You'll meet DOE regulations, save energy and improve the profitability of your irrigated fields. Our wide range of SINEWAVE OPTIMIZED motors, from 7-1/2HP to 600HP, are now in stock. If your application requires variable frequency drives, we stock NEMA Premium inverter duty motors from 15HP to 600HP.

*Find out more about our entire line of motors
at www.usmotors.com/pumps-systems.*

Nidec
NIDEC MOTOR CORPORATION

© 2018; All Rights Reserved.

U.S. MOTORS® is a registered trademark of Nidec Motor Corporation. Nidec Motor Corporation trademarks followed by the ® symbol are registered with the U.S. Patent and Trademark Office.



INDEX A-F

A

ABRASION RESISTANT INSULATION.....	M-32
ACCESSORY CONDUIT BOX—NEMA®.....	M-14
ACCESSORY CONDUIT BOX – TITAN®.....	M-18
ADAPTER BRACKETS	M-7
ADDITIONAL NAMEPLATES.....	M-37
AERATOR MOTORS.....	M-4
AIR FILTERS (WP II).....	M-25
AIR FILTER DIFFERENTIAL PRESSURE SWITCH.....	M-25
AIR TEMPERATURE SENSOR.....	M-25
ALTERNATE BASE DIAMETERS.....	M-7
ALTITUDE.....	M-4
AMBIENT TEMPERATURE.....	M-5
ANTIPLUGGING SWITCH.....	M-52
API TOLERANCES.....	M-74
ARTIC DUTY OPTION.....	M-5
AUTOTRANSFORMER – STARTING	M-54

B

BALANCE AND VIBRATION.....	M-6
BASE DIAMETERS.....	M-7
BEARINGS – INSULATED.....	M-11
BEARING LIFE DETERMINATION.....	M-8
BEARINGS – OPTIONAL THRUST CAPACITIES.....	M-10
BEARINGS – RECOMMENDED OILS.....	M-41
BEARINGS – SIZE IMPACT ON EFFICIENCY.....	M-10, M-22
BEARINGS – SPARE SET.....	M-7
BEARING TEMPERATURE PROTECTION.....	M-68
BOLTED COUPLING ON VHS.....	M-19
BREATHER DRAINS.....	M-21
BREATHER DRAIN FOR CONDUIT BOX.....	M-26
BUSHINGS – STEADY.....	M-54
BUSS BAR CONNECTION.....	M-12, M-18

C

CALIBRATION TEST.....	M-62
CAPACITORS – POWER FACTOR CORRECTION.....	M-44
CAPACITORS – SURGE.....	M-58
CAST-IRON CONDUIT BOX – NEMA.....	M-14
CAST-IRON FAN COVER GUARD (SEE “FAN COVER, CAST IRON”).....	M-26
CIRCULATING SHAFT CURRENT PROTECTION.....	M-11
CLASS INSULATION.....	M-29
CLASS TEMPERATURE RISE.....	M-60
CODE LETTER LOWER THAN STANDARD.....	M-54
COMPLETE INITIAL TEST.....	M-61
CONDUIT BOX -- ACCESSORY.....	M-14, M-18
CONDUIT BOX – DRAIN & BREATHER.....	M-21, M-26
CONDUIT BOX – LEAD POSITIONING GASKET.....	M-19
CONDUIT BOX – NEMA® FRAME SIZE.....	M-12
CONDUIT BOX – NEMA® TYPE 2.....	M-18
CONDUIT BOX – OVERSIZED.....	M-14
CONDUIT BOX – SPACE HEATER IN.....	M-19, M-51
CONDUIT BOX – TITAN® FRAME SIZE.....	M-12
CONNECTIONS.....	M-51

CONTINUOUS UPTHRUST.....	M-75
COOLING COILS.....	M-10
COPPER BAR ROTOR.....	M-47
CORRO-DUTY® PRODUCTS.....	M-30, M-35
CORRO-DUTY® PAINT JOB (SEE “PAINT”).....	M-42
CORRO-DUTY® WPI, WP11.....	M-24
COUPLINGS – BOLTED, SRC, NRR.....	M-19
COUPLINGS – PRESS ON HALF.....	M-20
CRATING OF MOTOR PRODUCTS.....	M-28
CURRENT – LOW STARTING.....	M-54
CURRENT TRANSFORMERS.....	M-20
CURVES – OF MOTOR CHARACTERISTICS.....	M-46
CYCLES – 50 HZ.....	M-29

D

DATA – SUBMITTAL.....	M-46
DB (A) – SOUND PRESSURE LEVELS.....	M-38
DIAL TYPE THERMOMETER – BEARINGS.....	M-63, M-69
DIFFERENTIAL PROTECTIONS (C.T.’S).....	M-20
DIMENSIONS – CONDUIT BOX – NEMA®.....	M-17
DIMENSIONS – CONDUIT BOX – TITAN®.....	M-17
DIMENSIONS – SUPPLIED WITH SUBMITTAL.....	M-46
DIVISION 1 HAZARDOUS LOCATION (SEE “ENCLOSURES”).....	M-27
DIVISION 2 HAZARDOUS LOCATION (SEE “ENCLOSURES”).....	M-28
DIVISION 2 NONLISTED (SEE “ENCLOSURES”).....	M-28
DOMESTIC CRATING OF MOTORS.....	M-28
DOUBLE DELTA STARTING.....	M-51
DRAIN AND BREATHER.....	M-21
DRAIN AND BREATHER IN CONDUIT BOX.....	M-21, M-26
DYNAMOMETER TESTING.....	M-61

E

EFFICIENCY.....	M-21
ELASTIMOLD CONNECTORS.....	M-19
ELEVATION (ALTITUDE).....	M-4
ENCLOSURES.....	M-24
EVERSEAL® (INSULATION).....	M-29
EXPORT BOXING.....	M-28
EXTRA HIGH THRUST (BEARINGS).....	M-10

F

FABRICATED ROTORS.....	M-47
FAN COVER, CAST IRON.....	M-26
FILTERS – AIR (WP II).....	M-24
FIRE PUMP	M-27
FORM WOUND COILS.....	M-31
FREQUENCY	M-29
FULL LOAD TEST (COMPLETE INITIAL).....	M-61



INDEX G-Q

G	
GATE VALVES.....	M-11
GROUND PROVISIONS.....	M-29
GRILLS – SCREENS.....	M-48
H	
HALF VOLTAGE SPACE HEATER.....	M-51
HARDWARE – STAINLESS STEEL.....	M-53
HEATERS – SPACE.....	M-51
HEATERS – OIL SUMP.....	M-40
HEATERS – MAIN CONDUIT BOX.....	M-19, M-51
HEAVY DUTY TEFC.....	M-26
HERTZ – 50 CYCLE.....	M-29
HORSEPOWER – NON-NEMA.....	M-29
HOSTILEDUTY™ – CORRO-DUTY®.....	M-26
I	
IDENTIFICATION PLATES – NAMEPLATES.....	M-37
IEEE® 45 SPECIFICATION – MARINE DUTY.....	M-35
841 PLUS® MODIFICATIONS.....	M-27
IMMERSION HEATERS.....	M-40
INPRO/SEAL®.....	M-48
INRUSH –REDUCED.....	M-58
INSULATED BEARINGS.....	M-11
INSULATION CLASS RATING.....	M-29
INSULATION (WINDING) TREATMENTS.....	M-31
INSULATION SYSTEM, ABRASION RESISTANT COATING.....	M-32
INVERTER DUTY PRODUCTS.....	M-33
INVERTERS AND THRUST BEARINGS.....	M-10
INTERNATIONAL SHIPMENTS.....	M-28
J	
JUNCTION (CONDUIT) BOX.....	M-12
K	
KEY LOCK ON CONDUIT BOX.....	M-19
L	
LEAD LUGS.....	M-65
LEAD POSITIONING GASKET.....	M-19
LEADS – LONGER THAN STANDARD.....	M-35
LEADS – POTTED.....	M-26
LEADS-TERMINATIONS (LUGS).....	M-65
LIGHTNING ARRESTORS.....	M-62
LIP SEALS (SEE “SEALS”).....	M-48
LONG-TERM STORAGE.....	M-89
LOW VOLTAGE STARTING.....	M-58

M	
MAIN CONDUIT BOX – NEMA®.....	M-12
MAIN CONDUIT BOX – TITAN®.....	M-15
MAINTENANCE PLATFORMS.....	M-42
MANOMETER (DIFF. PRESSURE SWITCH).....	M-25
MARINE DUTY.....	M-35
MECHANICAL RESONANCE.....	M-2
MOMENTARY UP THRUST.....	M-75
MOUNT HALF COUPLING.....	M-20
MULTISPEED MOTORS.....	M-35
– CONSTANT TORQUE.....	M-36
– VARIABLE TORQUE.....	M-36
N	
NAMEPLATES – SPECIAL.....	M-37
NOISE LEVELS – TYPICAL VALUES.....	M-38
NOISE TESTING.....	M-61
NON-NEMA HORSEPOWER.....	M-29
NON REVERSE RATCHET.....	M-39
O	
OIL DRAIN GATE VALVES.....	M-11
OIL – RECOMMENDED TYPES.....	M-41
OIL SUMP HEATERS.....	M-40
OPTIONAL OIL BATH GUIDE BEARINGS.....	M-11
OPTIONAL ROTOR CONSTRUCTION.....	M-47
OVERLOAD – SERVICE FACTOR.....	M-49
OVERSIZED BEARINGS (EHT).....	M-10
OVERSIZED (NEMA®) CONDUIT BOX.....	M-12
OVERSPEED.....	M-42
P	
PAINT.....	M-42
PAINT – CORRO-DUTY® PAINT JOB.....	M-42
PART WINDING START.....	M-55
PAYBACK ANALYSIS.....	M-22
PERFORMANCE CURVES.....	M-46
PILOT LIGHT FOR SPACE HEATER.....	M-52
PLATE BEARINGS.....	M-11
PLATFORMS LADDERS AND RAILINGS.....	M-42
POLARIZATION INDEX TESTING.....	M-62
POTTED LEADS.....	M-26
POWER FACTOR CORRECTION CAPACITORS.....	M-43
PREMIUM EFFICIENCY.....	M-21
PRESS ON HALF COUPLING.....	M-20
PRINTS AND DATA – SUBMITTALS.....	M-46
Q	
QUICK DISCONNECTS – ELASTIMOLDS.....	M-19



INDEX

R-Z

R

RANDOM WOUND STATORS.....	M-31
RATCHET – NONREVERSE.....	M-40
RECOMMENDED BEARING LIFE.....	M-6
REDUCED STARTING CURRENT.....	M-54
REDUCED VOLTAGE STARTING.....	M-54
REED CRITICAL FREQUENCY DATA.....	M-47
ROTATIONAL ARROW.....	M-37
ROTOR – COPPER BAR.....	M-47
ROTOR CONSTRUCTION.....	M-47
RTDs – BEARINGS.....	M-69
RTDs–WINDINGS.....	M-73

S

SCREENS – STAINLESS STEEL.....	M-48
SEALED INSULATION.....	M-32
SEALS (Inpro/Seal®).....	M-48
SELF-RELEASE COUPLING.....	M-19
SERVICE FACTOR.....	M-49
SEVERE DUTY.....	M-24, M-26
SERVIT POST (SEE “GROUNDING”).....	M-14, M-18
SHAFT GROUNDING RING.....	M-50
SHAFT SLINGER (SEE “SEALS”).....	M-48
SHAFTS – SPECIAL.....	M-50
SHAFT – SPECIAL RUNOUT.....	M-74
SHORT COMMERCIAL TEST.....	M-61
SOFTWARE.....	M-46
SOUND LEVELS.....	M-38
SPACE HEATER IN MAIN CONDUIT BOX.....	M-19, M-72
SPACE HEATER ON WINDING.....	M-51
SPACE HEATER PILOT LIGHT.....	M-52
SPARE ANTI-FRICTION BEARING SET.....	M-7
SPECIAL BALANCE.....	M-7
SPECIAL FEATURES NAMEPLATE.....	M-37
SPECIAL PAINT.....	M-42
SPECIAL SHAFT SEALS (REFER TO INQUIRY GROUP).....	M-78
SPECIAL VOLTAGE RATING.....	M-79
SPECIAL WARRANTY.....	M-52
SPEED SENSING SWITCH.....	M-52
SNOWMASTER™.....	M-51
STAINLESS-STEEL HARDWARE.....	M-53
STAINLESS-STEEL SCREENS.....	M-12
STAND-OFF INSULATORS – BUSS BAR.....	M-51
STAR-DELTA START.....	M-54
STARTING CURRENT – REDUCED.....	M-53
STARTING DUTY NAMEPLATES.....	M-53
STARTING METHODS.....	M-53
STEADY BUSHINGS.....	M-54
STRESS CONE CONDUIT BOX.....	M-15
SUBMITTAL DATA.....	M-46
SUMP HEATERS – OIL.....	M-40
SURGE PROTECTION.....	M-58

T

TEMPERATURE RISE.....	M-58
TERMINAL BOX – CONDUIT BOX.....	M-12

TERMINAL CONNECTORS – LEAD LUGS.....	M-61
TERMINAL STRIP CONNECTIONS.....	M-18
TESTING OF MOTORS.....	M-61
THERMAL PROTECTION – BEARINGS.....	M-68
THERMAL PROTECTION – WINDINGS.....	M-70
THERMA SENTRY® – WINDINGS.....	M-71
THERMISTORS (SEE “THERMAL PROTECTION”).....	M-70
THERMOCOUPLES–BEARINGS.....	M-69
THERMOCOUPLES – WINDINGS.....	M-73
THERMOSTATICALLY CONTROLLED SPACE HEATERS.....	M-52
THERMOSTATS.....	M-70
THRUST BEARINGS – EXTRA HIGH.....	M-10
THRUST BEARINGS – LOSSES.....	M-10
THRUST BEARINGS – WITH VFDs.....	M-33
TOLERANCES SPECIAL SHAFT AND FLANGE.....	M-74
TOTALLY ENCLOSED FAN COOLED (TEFC).....	M-25
TWO-SPEED CONSTANT TORQUE MOTORS.....	M-36
TWO-SPEED VARIABLE TORQUE MOTORS.....	M-36

U

U-FRAME MOTORS.....	M-6
UL® LISTED MOTORS (SEE “ENCLOSURES, HAZARDOUS LOCATION”).....	M-26
UL® LISTED FIRE PUMP.....	M-28
UPTHRUST OPTIONS.....	M-75

V

VFD – OPERATION – INSULATION SYSTEMS.....	M-33
VFD – THRUST BEARING CONCERNS.....	M-10, M-11
VIBRATION DETECTORS.....	M-75
VIBRATION LEVELS.....	M-6
VIBRATION TESTING.....	M-62
VOLTAGE OPTIONS.....	M-78
VPI INSULATION SYSTEMS.....	M-32

W

WARRANTY.....	M-79
WATER COOLING COILS.....	M-10
WATTS – SPACE HEATER RATINGS.....	M-52
WINDING PROTECTION.....	M-70
WINDING – RANDOM VS. FORM COILS.....	M-31
WINDING RTDs.....	M-73
WINDING THERMISTORS.....	M-70
WINDING THERMOCOUPLES.....	M-73
WINDING THERMOSTATS.....	M-70
WINDING TREATMENTS.....	M-31
WINDOW TYPE CURRENT TRANSFORMERS.....	M-20
WYE-DELTA STARTING.....	M-51

Z

ZERO-SPEED SWITCH.....	M-52
------------------------	------



MODIFIABLE PRICING INSTRUCTIONS

AERATOR ALTITUDE

1. AERATOR MOTOR - TYPE TVC-9, JVC-3

This specific purpose TEFC vertical solid shaft medium-thrust motor is available from 5 to 200 HP in single-speed (1800-1200-900 RPM) or multi-speed (1800/1200, 1800/900, 1200/900) designs. Features include all cast-iron construction (fan cover guard on Titan® motors is heavy fab steel) with CORRO-DUTY® protective treatments, a special sealant applied between the frame and register fit of each bracket, potted leads, a drain and breather in the low point of motor, Class F insulation and 1.15 SF. This product is shown prepriced in its single-speed form on page P-66 - P-68. Ratings not shown require review and approval of the Inquiry Group. When approved, use the TEFC VSS normal thrust price as a base and add 15% to include the above features on single-speed products. Also add per item 22 on page M-35 if multispeed is required. For available voltages, refer to item 53 on page M-78 of this section (multispeed motors are available as single voltage ratings only). Does not include special shafts. For special shafts, refer to item 38 on page M-49 of this section.

2. ALTITUDE

Standard motors are designed for 3300 feet altitude and 40°C ambient temperature. Atmospheric conditions at higher altitudes inhibit the motor's ability to dissipate heat, resulting in an increased temperature rise and a reduced motor capacity. NEMA standards state motor temperature will increase 1% for each 330-foot increment above the standard 3300-foot altitude design point. Ambient temperatures generally drop with an increase in altitude and are normally less than 40°C, even when installed indoors. Motors can be specifically designed for higher altitudes or derated, either due to lower ambient temperatures or by reducing output capacity.

- To maintain motor service factor in altitudes of 3301 to 9900 feet (1006 to 3018 meters), add per below:

FRAME SIZE	182	213	254	284	324	364	404	444	449
	184	215	256	286	326	365	405	447	
LIST PRICE	\$164	\$197	\$261	\$434	\$570	\$732	\$1,063	\$1,498	\$4,068

FRAME SIZE	5000	5800	6812 (TE)	6800-8000	9600
LIST PRICE	6%	6%	6%	6%	6%

- Altitudes above 9900 feet require mandatory review by the Inquiry Group. When approved, add 20% to the list price.
- DERATING FACTORS** -- Standard designs may be operated at the following altitude by reducing the output capacity of the motor by the derating factor shown. Does not apply to hazardous location. Nameplate will not acknowledge high-altitude use.

ALTITUDE (FT.)	DERATING FACTOR
3300-5000	0.97
5001-6600	0.94
6601-8300	0.91
8301-9900	0.88
9901-11500	0.85

- ADJUSTMENT DUE TO REDUCED AMBIENT TEMPERATURE** -- Standard designs may be operated at the following altitudes due to reduced ambient temperatures. Does not apply to hazardous location. Nameplate will not acknowledge high-altitude use.

MAXIMUM ALTITUDE IN FEET	AMBIENT (DEGREES C)
3300	40°C
6600	30°C
9900	20°C



† All marks shown within this document are properties of their respective owners.

MODIFIABLE PRICING INSTRUCTIONS



3. AMBIENT TEMPERATURE

Standard designs described in this catalog are suitable for operation in ambient temperatures ranging from +40°C (104°F) to -30°C (-22°F). When standard designs are consistently exposed to ambient temperatures between -5°C (23°F) and -30°C (-22°F), special lubrication practices may be required. Additional precautions such as space heaters and/or oil sump heaters may be required depending on such factors as starting methods and duty cycle. Clearly state low ambient requirements on inquiries to the Inquiry Group and order documents if product will be consistently exposed to -5°C to -30°C ambients.

NOTE: The minimum ambient temperature for standard hazardous location motors is -25°C. See ARCTIC DUTY for ambient temperatures below -25°C.

A. ARCTIC DUTY -- LOW AMBIENT APPLICATION

Available option for TEFC high-thrust, normal-thrust and in-line pump motors applied in ambients of -30°C (-22°F) to -56°C (-70°F). Add 25% to the list price to provide any required special electrical, lubrication and mechanical features (CORRO-DUTY® features are included). Hazardous location arctic duty vertical motors require mandatory review by the Inquiry Group. A nonreverse ratchet is not available on hazardous location arctic duty products. When approved by the Inquiry Group, add 25% to the hazardous location list price. Price does not include heaters for oil sump or motor winding.

**High tensile strength cast iron frame may be required. Refer to engineering for confirmation, if required add 225% to Standard Base list price.*

B. HIGH AMBIENT APPLICATION

To provide motors suitable for installation in ambient temperatures between 41°C and 65°C, make the list price addition shown below. Motor temperature rise will change from stated price book values with ambient temperatures above 40°C. Price book stated performance values, frame sizes and lubrication specifications are also subject to change. For confirmed data, refer to the Inquiry Group. For ambient temperature ratings over 65°C, check with Inquiry Group.

NEMA®† FRAME 41-65°C AMBIENT PRICE TABLE

FRAME SIZE	182	213	254	284	324	364	404	444	449
	184	215	256	286	326	365	405	447	
LIST PRICE	\$164	\$197	\$261	\$434	\$570	\$732	\$1,063	\$1,498	\$4,068

TITAN® FRAME 41-65°C AMBIENT PRICE TABLE

FRAME SIZE	5000-5800		6812	6800-9600
ENCLOSURE	OPEN	TEFC*	TEFC	OPEN
LIST ADDITION	12%	6%	12%	15%

**For hazardous location motors, obtain confirmed frame size from the Inquiry Group; price by frame and add 3% to the list price.*

Motors with oil lubricated thrust bearings will also require cooling coils for ambient temperature from 55°C - 65°C see cooling coils item 6.B.9 on M-10.

Motors with 1.15 SF may be derated to 1.0 SF for use in a 50°C ambient with no reduction in nameplate H.P. (Rated output). Non-hazardous location motors with 1.0 SF can be derated to accommodate ambient temperatures 40°C to 50°C by applying the following correction factors. Correction factors can be used, but actual performance will differ from published values.

Ambient Temperature	45°C	50°C
Rated Output reduced to	95%	90%



MODIFIABLE PRICING INSTRUCTIONS

BALANCE

4 BALANCE AND VIBRATION

NEMA standard MG1, Part 7, requires vibration readings to be measured in terms of velocity and stated as inches per second (IPS). Velocity is defined as the maximum speed at which displacement occurs. It takes into consideration both maximum displacement and time. To illustrate velocity, think of a point moving along a typical sine wave in a rising and falling fashion. As the point rises to its peak displacement (Point A), the velocity of movement is zero since it is about to change direction and must stop to do so. Changing direction, the point accelerates towards its peak displacement in the opposite direction (Point C). Midway between the peak displacement values (Point B), velocity is at its maximum. Since the velocity of motion is changing throughout its cycle, the highest peak is selected for measurement.

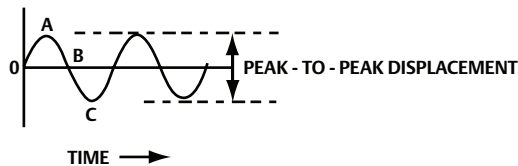

Nidec Motor Corporation balances all vertical motors to meet the standard limits shown below. For a refined balance, make the list adders indicated for normal, medium and high thrust motors.

VIBRATION LEVEL

	STANDARD	REFINED
Number of Poles	Velocity (IPS-PEAK)	Velocity (IPS-PEAK)
2	0.15	0.10
4	0.15	0.08
6	0.15	0.08
8	0.12	0.06
10	0.09	0.05
12	0.08	0.04

LIST PRICE ADDITION FOR REFINED BALANCE

THRUST RATING	182 184	213 215	254 256	284 286	324 326	364 365	404 405	444 447	449
NORMAL/MEDIUM	\$141	\$141	\$141	\$141	\$202	\$202	\$202	\$202	\$735
HIGH THRUST	\$282	\$282	\$282	\$282	\$404	\$404	\$404	\$404	\$1,467

FRAME RATING	5000	5800	6812 (TE)	6800-8000	9600
LIST PRICE	\$1,467	\$4,354	\$4,354	\$5,444	\$5,444



† All marks shown within this document are properties of their respective owners.

MODIFIABLE PRICING INSTRUCTIONS



5. BASE DIAMETERS

A. ADAPTER BASES, 449-6800 FRAME

Adapter or transition bases for 449TP through 6812VP frames call for review by the Inquiry Group due to their special requirements and impact on mechanical resonance. With approval, add as follows:

Frame Size	List Adder
449/5000	\$3,756
5800	\$5,634
6808-6812	\$7,518

Adapter brackets may impact delivery schedules.

B. NON-STANDARD BASES 6813 - 9600 FRAMES

6813, 8000 and 9600 frame standard P-base diameters are shown on the respective price book pages. Should the customer require a non-standard P-base diameter, add as follows (6813, 8000 and 9600 frames only).

Special lower brackets require review by the Inquiry Group prior to quotation as the weight may impact standard mechanical design.

Diameter	List Adder
46 to 49	\$3,756
50 to 55	\$5,282
56 to 60	\$11,737
61 to 65	\$15,023
66 to 71	\$19,484

For diameters over 71 inches, refer to the Inquiry Group.

6. BEARINGS

A. SPARE SET

A spare set of antifriction bearings can be ordered for modifiable motors only, when entered with the motor order. Add 7% to the base list price. For a spare plate bearing, refer to the Inquiry Group.



MODIFIABLE PRICING INSTRUCTIONS

BEARINGS

6. BEARINGS (continued)

B. BEARING LIFE

Customer specifications often require a vertical motor to meet a specific bearing life, normally stated in terms of hours or years. This time interval is further qualified as being either a minimum or average value.

The ABMA designation used to specify minimum bearing life is L-10 and is defined as the number of hours that 90% of a group of identical bearings will complete or exceed before the first evidence of fatigue develops. Average bearing life is designated as L-50 and is five times the L-10 life value.

Our price book thrust capacities are based on a 1 year L-10 or a 5 year average bearing life unless otherwise stated. Bearing life has an inverse relationship to our stated thrust capacities; that is, life will increase with a decrease in load or decrease with an increase in load. Therefore, in order to meet a specific bearing life, we must know the actual downthrust of the pump at design conditions. If the specification requires the life to be evaluated at the worst case condition, we would also need to know the shut-off thrust value.

To meet a specific bearing life, we must derate the price book values by a time factor. Example: 100HP, 1800 RPM, VHS WPI motor with a price book standard high-thrust capacity of 6700 lbs. is applied to a pump with a downthrust of 4415 lbs. The specification requires 40,000 hours minimum L-10 bearing life.

Step 1: Select the time factor from the list below for 40,000 hours L-10 (1.43).

Step 2: Divide motor thrust capacity by this value (6700/1.43). This yields the maximum allowable thrust value to meet 40,000 hours L-10. (4680 lbs. maximum D.T.)

Step 3: Compare actual requirement (5000 lbs.) to maximum allowable thrust value (4680 lbs.). If the actual load is less than the derated capacity, the motor meets the specification.

Step 4: If the actual load exceeds the derated capacity, extra high thrust (EHT) is required. To determine how much extra high thrust is required, multiply maximum allowable value (4680 lbs) by chosen EHT (175%) value. If this value equals or exceeds the actual condition, specification requirements are met. Add for 175% EHT.



MODIFIABLE PRICING INSTRUCTIONS



6. BEARINGS (continued)

VERTICAL MOTOR BEARING LIFE TIME FACTORS FOR ANTIFRICTION BEARINGS

Price book thrust capacities are based on 1 year minimum (L-10) or 5 year average (L-50) life.

L-10 Minimum Life		Thrust Capacity	L-50 Average Life	
Years	Hours	Time Factor	Years	Hours
1	8800	1.00	5	44000
1.2	10560	1.04	6	52800
1.4	12320	1.08	7	61600
1.6	14080	1.12	8	70400
1.8	15840	1.15	9	79200
2	17600	1.18	10	88000
2.3	20000	1.22	11.5	100000
2.4	21120	1.23	12	105000
2.8	25000	1.28	14	125000
3	26400	1.30	15	132000
4	35200	1.37	20	176000
4.5	40000	1.43	22.5	200000
5	44000	1.47	25	220000
5.7	50000	1.51	28.5	250000
6	52800	1.53	30	264000
6.8	60000	1.58	34	300000
8	70400	1.64	40	352000
8.5	75000	1.67	42.5	375000
10	88000	1.73	50	440000
11.4	100000	1.78	57	500000



MODIFIABLE PRICING INSTRUCTIONS

BEARINGS

6. BEARINGS (continued)

B. BEARING LIFE

NOTES:

1. THESE VALUES APPLY ONLY TO ANTI-FRICTION (rolling element) bearings.
2. Statistically derived extended bearing life has certain limits beyond which it is no longer practical to add bearing capacity to increase life. Changing future conditions in the pump load will impact bearing life. Further, the user must maintain the product with care during storage, installation and operation.
3. Nidec Motor Corporation recommends the specifying engineer base the requirement upon the design life of the plant. By far, the most common plant design life is 20 years. From a conservative viewpoint, we recommend the following:

Plant Design Life	Minimum L-10	Average L-50
20 years	5 years	25 years
30 years	6.8 years	34 years
40 years	8.5 years	42.5 years

4. Nidec Motor Corporation uses IEEE 112 method B for our efficiency calculation of NEMA Nominal Efficiency. Increasing thrust capacity over stated standard high-thrust values to meet a specified bearing life will decrease motor full load efficiency at operating conditions due to the additional losses of larger capacity bearing arrangements. For 175% EHT, deduct 0.2 from efficiency values, for 300% EHT deduct 0.4 from efficiency values. For over 300% EHT, refer to the Inquiry Group. For a more accurate efficiency value for EHT motors, refer to the Inquiry Group.
5. 300% EHT requires spherical roller bearings of two-piece construction. Inherent to their design is a need for a minimum amount of downthrust to be applied at all times (refer to the Inquiry Group for values). Should a 300% EHT machine be applied to a pump driven by an inverter, care must be taken to insure this minimum downthrust load is present over the entire speed range. Otherwise, **severe non-warranty damage will result**. Pumps sized for future conditions are also subject to this problem.
6. Extended minimum bearing life has no impact on our standard warranty. Bearings will be selected to meet specified life but will carry the same warranty as the rest of the motor.
7. 175% EHT is available only on frame sizes 324 through 8011, open and enclosed. Add 4% to the list price.
8. 300% EHT is available only on frame sizes 444 through 9608 with, WPI, WP11 enclosures and 449 through 6812 frame sizes with TEFC enclosures. Not available on 5008 Hazardous Location. Add 7.5% to the base list price. (On 2 pole requirements, refer to the Inquiry Group.)
Any requirements above 300% must be referred to the Inquiry Group. Add 10% for 500% EHT if approved.
9. Water cooling coils for thrust bearing oil sumps are available on 324 through 9608, WPI and WP11 frames as well as 449 through 6812 TEFC frames. 300% EHT (and above) antifriction bearing arrangements may require water cooling coils in the oil bath. Plate type bearing arrangements always require this feature. Both of these bearing configurations are designed to handle very high pump thrust loads. Because these configurations generate tremendous heat buildup in the oil bath, water cooling coils help dissipate the heat and maintain oil viscosity.
 - Nidec Motor Corporation's standard water cooling coils are designed from copper construction to be self draining and require a minimum of 4 GPM at a maximum of 125 PSI with an inlet temperature of 90° F or less.
 - When a customer requires water cooling coils and they are not standard, add 5% to the list price for copper cooling coils, add 7.5% for stainless steel cooling coils.



MODIFIABLE PRICING INSTRUCTIONS



6. BEARINGS (continued)

B. BEARING LIFE

10. Oil-lubricated lower (guide) bearings are provided as standard on high-thrust WPI and WP11 motors with 5813 through 9608 frames sizes and on high-thrust TEFC motors with 5008 through 6812 frame sizes.

Oil-lubricated lower bearings are available as an option on high-thrust 4-Pole and slower WPI and WP11 motors with 5008 through 5012 frame sizes. When required, add \$1,913 to the list price. Note when providing this feature, the VHS BX dimension is limited to 2.50" and the VSS "U" dimension is limited to 3.125".

11. Gate valves and extended oil drains. Motors with oil-lubricated bearings are supplied with suitable provisions for draining the oil sumps. In some cases, the customer may require a pipe extension and a gate valve to allow for more convenient oil changes. The typical extension length is four inches. To include this feature when oil-lubricated bearings are standard, add to the list price as follows:

Upper sump per motor, add \$880 list adder:

high-thrust WPI and WP11 447 through 5012 frame
 high-thrust TEFC motors 447 through 449 frame

Upper and lower sumps per motor, add \$1,761 list adder:

high-thrust WPI and WP11 6808 through 9608 frame
 high-thrust TEFC motors 5008 through 6812 frame

12. An insulated thrust bearing to prevent circulating shaft currents is a standard feature on all motors in the 5008 through 9608 frame series. Should a customer require an insulated bearing on a smaller frame or on both bearings for a 180 frame or larger, make the appropriate list price adder shown below.

Insulated Bearing (Upper Bearing)

Frame:	182 184	213 215	254 256	284 286	324 326	364 365	404 405	444 447	449	5000	5800	6812 (TE)	6800-8000	9600
Adder:	\$550	\$850	\$1,200	\$1,500	\$1,500	\$1,500	\$1,500	\$1,500	\$1,800	\$0	\$0	\$0	\$0	\$0

Insulated Bearing (Both Bearings)

Frame:	182 184	213 215	254 256	284 286	324 326	364 365	404 405	444 447	449	5000	5800	6812 (TE)	6800-8000	9600
Adder:	\$1,100	\$1,700	\$2,400	\$3,000	\$3,000	\$3,000	\$3,000	\$3,000	\$3,600	\$2,400	\$2,400	\$3,000	\$3,000	\$3,000

13. PLATE TYPE THRUST BEARINGS.

- Available only on 9600 frame sizes - solid shaft motors only
- Actual worst case (shut-off) thrust values must be known to properly quote this option
- This option may extend delivery
- Full-load test not available

Plate-type bearings offer the highest thrust carrying capacity of all configurations offered by Nidec Motor Corporation. Unlike rolling element bearings, these operate on an oil film and have little, if any, overload capacity. Overload will quickly result in failure. This arrangement also has the greatest impact on motor efficiency due to its high losses. The engineer or user concerned with product performance should be apprised of this. When properly applied and maintained, this bearing has an infinite theoretical life and is always supplied with water cooling coils. Inherent to its design, this option requires an auxiliary bearing system to handle upthrust and radial loads. Refer to marketing for price and availability.



† All marks shown within this document are properties of their respective owners.

MODIFIABLE PRICING INSTRUCTIONS

**BUSS BAR
CONDUIT BOX**

7. BUSS BAR CONNECTIONS

For three insulated standoffs with buss-bar terminations for incoming supply cables, add \$4,178 to the list price. Available in 449 frame sizes and larger only. Double adder for 2 speed/2 winding motors. Does not imply a phase segregated arrangement.

8. CONDUIT BOX ARRANGEMENTS

A. NEMA^{®†} FRAME (182-447)

Standard product is supplied with a single main conduit box that can be rotated in 90° steps to position the single entrance hole according to the power feeder cable. The typical "A-A" dimension to accommodate feeder cables for the 182-215 frame is 1.0 inches, the 254-256 frame is 1.25 inches, the 284-286 frame is 1.5 inches, and the 324-447 frame is 3.0 inches. Refer to dimension prints for your specific product. Standard box is a NEMA 3 enclosure.

- The standard conduit box material for aluminum-frame WPI and TEFC motors in the 182-286 frame is aluminum or steel
- The standard conduit box materials for cast-iron frame WPI and TEFC motors in the 324-447 frame size is steel or cast iron
- CORRO-DUTY[®] TEFC and all hazardous location motors are supplied with a cast-iron conduit box

Typical descriptions for NEMA^{®†} Verticals*

Motor Type	Box Use	Ref. Note	Box Matl	Nidec Motor Corporation Vol.	A-A Dim	THD Hub	Internal Casting Dimensions			Bolt Pattn (SQ)
							H	W	D	
FRAME SIZE 182-184										
TEFC	STD		AL	60	1.0	NO	3.6	5.7	2.9	A
CDUTY	STD	(4)	CI	36	1.0	YES	3.8	4.1	2.3	2.125
XP	STD		CI	36	1.0	YES	3.8	4.1	2.3	2.125
FRAME SIZE 213-215										
WPI	STD		AL	60	1.0	NO	3.6	5.7	2.9	A
TEFC	STD		AL	60	1.0	NO	3.6	5.7	2.9	A
CDUTY	STD	(4)	CI	36	1.0	YES	3.8	4.1	2.3	2.125
XP	STD		CI	36	1.0	YES	3.8	4.1	2.3	2.125
FRAME SIZE 254-256										
WPI	STD		AL	66	1.25	NO	4.5	3.9	3.8	A
TEFC	STD		AL	90	1.25	NO	4.0	6.6	3.4	A
CDUTY	STD	(4)	CI	60	1.5	YES	4.37	4.37	3.1	2.5
XP	STD		CI	60	1.5	YES	4.37	4.37	3.1	2.5
FRAME SIZE 284-286										
WPI	STD	(1)	AL	100	1.5	NO	4.6	4.6	4.7	2.5
TEFC	STD	(1)	AL	137	1.5	NO	4.9	8.4	3.3	2.5
CDUTY	STD	(1)	CI	186	2.0	YES	7.0	5.8	4.6	2.5
XP	STD	(1)	CI	186	2.0	YES	7.0	5.8	4.6	2.5



† All marks shown within this document are properties of their respective owners.

MODIFIABLE PRICING INSTRUCTIONS

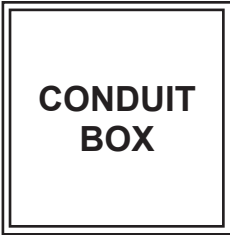

8. CONDUIT BOX ARRANGEMENTS (continued)

A. NEMA^{®†} FRAME (182-447)

Motor Type	Box Use	Ref. Note	Box Matl	Nidec Motor Corporation Vol.	A-A Dim	THD Hub	Internal Casting Dimensions			Bolt Pattn (SQ)
							H	W	D	
FRAME SIZE 324-326										
WPI	STD		STL	347	3.0	NO	8.0	6.5	6.88	4.0
WPI	OPT	(1)	CI	330	3.0	YES	8.5	7.25	6.88	4.0
TEFC	STD		STL	195	2.0	NO	6.75	5.5	5.38	2.5
TEFC	OPT	(2)	CI	194	2.0	YES	7.0	6.5	5.125	2.5
XP	STD		CI	194	2.0	YES	7.0	6.5	5.125	2.5
FRAME SIZE 364-365 404-405										
WPI	STD		STL	347	3.0	NO	8.0	6.5	6.88	4.0
WPI	OPT	(1)	CI	330	3.0	YES	8.5	7.25	6.88	4.0
TEFC	STD		STL	347	3.0	NO	8.0	6.5	6.88	4.0
TEFC	OPT	(1)	CI	330	3.0	YES	8.5	7.25	6.88	4.0
XP	STD		CI	542	3.0	YES	9.0	10.75	7.63	4.0
FRAME SIZE 444-445 **										
WPI	STD		STL	563	3.0	NO	9.5	7.75	7.75	5.0
WPI	OPT	(3)	CI	525	3.5	YES	9.5	9.0	6.0	5.0
TEFC	STD		STL	563	3.0	NO	9.5	7.75	7.75	5.0
TEFC	OPT	(3)	CI	525	3.5	YES	9.5	9.0	6.0	5.0
XP	STD		CI	542	3.0	YES	9.0	10.75	7.63	5.0
FRAME SIZE 447										
WPI	STD		CI	2000	3.5	YES	16.25	16.0	10.25	5.0
TEFC	STD		STL	563	3.0	NO	9.95	7.75	7.75	5.0
TEFC	OPT		CI	525	3.5	YES	9.95	9.0	6.0	5.0
XP	STD		CI	542	3.0	YES	9.0	10.75	7.63	5.0

*Subject to change due to NEMA or NEC requirements and/or Nidec Motor Corporation good engineering practices.

** 250 HP - 1300 cubic inch cast box.

NOTES: Cast-iron conversion kits for stock motors are (1) P/N 888949, (2) P/N 888948, (3) P/N 888940 (4) Modified may deviate larger (A) Bolt pattern is 2.375 x 1.875, STD=Standard, OPT=Optional, STL= Steel, AL=Aluminum, CI=Cast Iron, THD HUB= Threaded Hub. Volume is in cubic inches.

NEMA 4X EPOXY COATED CONDUIT BOX

FRAME SIZE	182	213	254	284	324	364	404	444	447
	184	215	256	286	326	365	405	445	
LIST ADDER	\$352	\$469	\$587	\$704	\$822	\$939	\$1,056	\$1,174	\$1,174

*All conduit boxes will be painted internally and externally with an epoxy paint that meets the requirements of UL 1332 for NEMA 4X enclosure per NEMA 250



MODIFIABLE PRICING INSTRUCTIONS

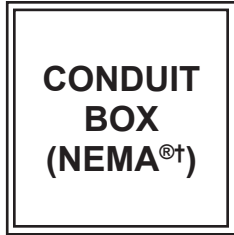

8. CONDUIT BOX ARRANGEMENTS (continued)

A. NEMA®† FRAME (182-447)

- To provide a standard size cast-iron conduit box with a single 3.0 inch diameter threaded hub (A-A dimension), add the list adder shown below:

FRAME SIZE	324 326	364 365	404 405	444 447
LIST ADDER	\$293	\$469	\$587	\$704

For 324-447 frame WPI and TEFC motors only.

- Special oversized cast iron conduit box selections for NEMA frame (400-440) motors are as follows:

LIST PRICE ADDITIONS NEMA®† - TITAN® CROSSOVER OPTIONS

Titan Size	Frame ⁽¹⁾	List	Material	Vol In ³	Qty Hubs
1.0	400	\$1,056	Cast Iron ⁽²⁾	900	1-3.5"
1.0	440	\$939			
1.5	400	\$3,052	Cast Iron ⁽²⁾	3200	2-3.5"
1.5	440	\$2,817			
2.0	400	\$1,526	Cast Iron	1300	1-3.5"
2.0	440	\$1,408			
2.5	400	\$2,817	Cast Iron	2000	1-3.5"
2.5	440	\$2,580			
3.0	400	\$3,580	Cast Iron	3400	2-3.5"
3.0	440	\$3,343			

Notes: (1) 400 frame requires an adapter plate that will increase NEMA AB and AC dimensions
(2) Hazardous location motors only

- Ground -- For a ground lug (GL) inside of the conduit box, add \$108 to the list price. (Standard on CORRO-DUTY®, severe duty, and hazardous location options).
- Oversize -- For a steel conduit box one size larger than standard, add \$178 list for 180-400 frames. Add \$704 list for 440 frame. Does not apply to TITAN® motors. (Not available with item 2)
- For double gasketed or NEMA®† 4 protection, add \$178 to the list price. (Standard on CORRO-DUTY® and severe-duty options)
- For an accessory conduit box (324-447 frames only) to terminate the leads of internal accessories such as space heaters, thermostats, etc., in a separate dedicated conduit box, add \$901 to the list price.
- For an oversized accessory conduit box (320-447 frames only) with terminal strip connectors and the capability to terminate up to two external accessories (vibration detector, bearing RTD, etc.), add \$1803 to the list price. To prewire external accessories to this box, add \$188 each to the price list.
- For prewire of vibration detectors to accessory conduit box, add \$376 each to the list price



† All marks shown within this document are properties of their respective owners.

MODIFIABLE PRICING INSTRUCTIONS

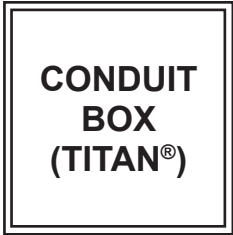

8. CONDUIT BOX ARRANGEMENTS (continued)

B. TITAN® FRAME (449-9600)

The standard product is supplied with a large, single, main conduit box of cast iron or fabricated steel as shown in the table on page P-102. It typically has one usable 3-1/2 inch diameter threaded conduit hub (A-A dimension). If specified at order entry, Nidec Motor Corporation will provide up to three threaded hubs that are up to 4.0 inches in diameter available on size 3.5, 4.5, 6 or 8 boxes. Most options can be rotated in 4 steps of 90° to accept top, bottom or side feeder cable positions. When physical size will not allow the box to be rotated (size 3.5, 4.5, 6, 8), specify desired location of the hub(s). If not specified, the size and location will be as shown on the following pages. All conduit boxes meet NEMA Type 4 enclosure requirements.

Standard conduit box assignments and available options are illustrated in the table on the following page. Certain accessories require an oversized main conduit box. The cost of this feature is not included in the accessory price unless otherwise stated. To interpret which conduit box is required to accommodate the desired features, refer to the index below before selecting the appropriate conduit box from the assignment table. Lightning arrestors and surge capacitors on motors rated 600V and less can be accommodated in a Size 3 box.

SELECTION INDEX

- A-OPTION Oversized terminal box for extra or larger leads or stress cones
- B-OPTION Accommodates stress cones with one of the following: lightning arrestors, surge capacitors, current transformer, or buss connection
- C-OPTION Accommodates stress cones with any two of the following: lightning arrestors, surge capacitors, current transformer, or buss connection
- D-OPTION Terminal box accommodates all components: stress cones, lightning arrestors, surge capacitors, current transformer, and buss connection

Note: Stress cones are not an Nidec Motor Corporation-supplied accessory but rather a method of connecting motor leads to shielded feeder cables often selected by the customer. Stress cones typically require an oversize box to simply make this connection.

NEMA 4 X CONDUIT BOXES

NEMA 4X EPOXY COATED CONDUIT BOX Stainless-Steel

Selection Chart	Vertical NEMA 4X (S.S.) Adder
BTD Condulet	\$2,250 per BTD
Acc. C/B**	\$4,155 per Box
Size 2.5	\$8,070
Size 3	\$10,445
Size 3.5	\$12,030
Size 4.5	\$14,905
Size 5	\$20,100
Size 6	\$24,120
Size 8	\$28,945

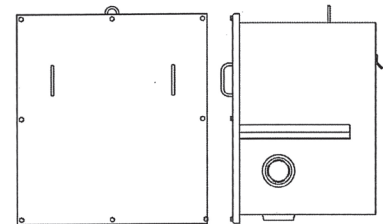

*All boxes will be externally coated with same paint as motor
**Includes Terminal Board

EPOXY PAINT COATED

Selection Chart	Vertical NEMA 4X (Epoxy Painted) Adder
All Conduit Box*	\$1,878

*All conduit boxes will be painted internally and externally with an epoxy paint that meets the requirements of UL 1332 for NEMA 4X enclosures per NEMA 250



MODIFIABLE PRICING INSTRUCTIONS

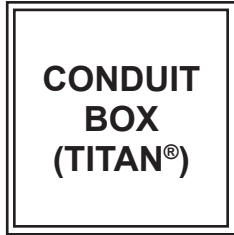

8. CONDUIT BOX ARRANGEMENTS (continued) B. TITAN® FRAME (449-9600)

MAIN CONDUIT BOX SELECTION TABLE

Enclosure	Frame	Voltage	Horsepower	Conduit Box Options					
				STD	A	B	C	D	
Div. 1 Hazardous Location	5000	460 & 2300	ALL	1	1.5	N/A	N/A	N/A	
	5800	4000	ALL	1.5	1.5	N/A	N/A	N/A	
TEFC	449 5000 5807 5809 5811	460	UP TO 500	2	3	4.5	5	6	
			501 & UP	3	4.5	4.5	5	6	
		2300	ALL	2	3	4.5	5	6	
		4000	ALL	2.5	3	4.5	5	6	
		6600	ALL	3.5	4.5	8	8	8	
	5812	460	ALL		3	3	4.5	5	6
					3	3	4.5	5	6
		2300	ALL	3	3	4.5	5	6	
		4000	ALL	3	3	4.5	5	6	
		6000	ALL	3.5	4.5	6	8	8	
	6812	460	ALL	4.5	4.5	4.5	5	6	
		2300	ALL	4.5	4.5	4.5	5	6	
		4000	ALL	4.5	4.5	4.5	5	6	
		6000	ALL	4.5	4.5	6	8	8	
	WPI WP11	449 5000 5800	460	UP TO 499	2.5	3	4.5	5	6
500 & UP				3	3	4.5	5	6	
2300			ALL	3	3	4.5	5	6	
4000			ALL	3	3	4.5	5	6	
6000			ALL	3.5	4.5	6	8	8	
6800 8000 9600		2300	ALL	3	4.5	4.5	5	6	
		4000	UP TO 1000	3	4.5	4.5	5	6	
			1001 & UP	4.5	4.5	4.5	5	6	
		6000	ALL	3.5	4.5	6	8	8	

Motors rated 3300 Volt will follow same guidelines as 4000 Volt shown in the table above.
Motors rated for voltages above 4800 Volt will use a Size 3.5 box as standard.
Size 8 box is only available on motors with voltages above 5000 Volt.

LIST PRICES FOR OPTIONAL MOTOR MOUNTED MAIN CONDUIT BOXES

SIZE	LIST ADDER	MATERIAL	VOLUME IN ³
1.5	\$3,521	C.I.	3200
2.5	\$3,228	C.I.	2000
3	\$4,178	C.I.	3400
3.5	\$4,812	F.S.	5700
4.5	\$5,962	F.S.	16200
5	\$8,040	F.S.	28000
6	\$9,648	F.S.	40400
8	\$11,578	F.S.	48200

CI = CAST IRON F.S. FABRICATED STEEL

Reference drawings for conduit box selection are shown on the following page with standard location of threaded hubs as indicated.



† All marks shown within this document are properties of their respective owners.

MODIFIABLE PRICING INSTRUCTIONS

CONDUIT
BOX
(TITAN®)

8. CONDUIT BOX ARRANGEMENTS (continued) B. TITAN® FRAME (449-9600)

REFERENCE DRAWINGS

TYPICAL PROFILE FOR
SIZES 1, 1.5, 2, 2.5, AND 3

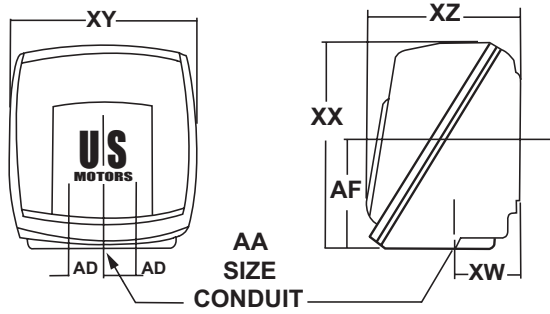

Dimensions may vary up to 1/4" due to casting or fabrication variations.

TYPICAL PROFILE FOR
SIZES 3.5, 4.5, AND 6

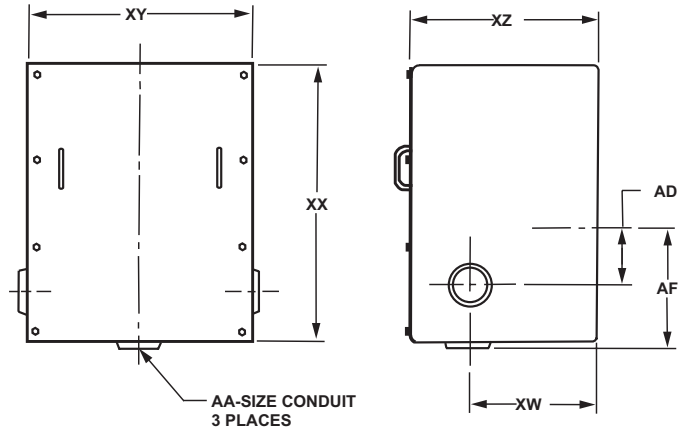

MODIFIABLE PRICING INSTRUCTIONS

**CONDUIT
BOX
(TITAN®)**

8. CONDUIT BOX ARRANGEMENTS (continued)

B. TITAN® FRAME (449-9600)

TITAN® CONDUIT BOX REFERENCE DIMENSIONS

BOX SIZE	QTY HUBS	AF	AD	XW	EXTERIOR			INTERIOR			CONST. MAT'L	USABLE VOLUME
					XX (H)	XY (W)	XZ (D)	XX (H)	XY (W)	XZ (D)		
1	1	5-5/8	---	3-15/16	14	14	10-5/8	11-3/8	12	9-1/2	C.I	900
1.5	2	8-5/8	3	6-1/8	19	18	16-1/2	17-1/2	15	15	C.I	3200
2	1	8-1/16	---	5	15	14	10-1/2	13-1/2	11-1/2	9-1/2	C.I	1300
2.5*	1	10	---	6	17-3/4	18	11-1/2	16	15	10	C.I.	2000
3	2	10-15/16	3	8-1/8	19	19-3/8	17-5/32	16-1/8	15-3/8	13-5/8	C.I.	3400
3.5	3	10-13/16	4	8	24	18	14	23-3/4	17-3/4	13-5/8	F.S.	5700
4.5	3	17-13/16	11	14	30	28	20-1/8	29-1/2	27-3/4	19-3/4	F.S.	16200
5	3	19-13/16	13	14	40	36	20	39-3/4	35-3/4	19-5/8	F.S.	28000
6	3	19-13/16	13	24-1/2	40	32	29	39-3/4	35-3/4	28-5/8	F.S.	40400
8	3	19-13/16	13	24-1/2	48	32	29	47-1/2	35-1/2	28-5/8	F.S.	48200

NOTES: C.I. = CAST IRON, F.S. = FABRICATED STEEL

*WPI/WPII 449 frame up to 450HP has a size 2.5 box with Qty. 2 hubs.

TITAN® Conduit Box Options & Accessories

- For a ground lug or servit post mounted in the conduit box, add \$164 to the list price.
- For a single accessory conduit box used to terminate the leads of internal devices (space heaters, thermostats, etc.) to a dedicated location, add \$1,127 to the list price. (Accessory box is shown on dimension prints.)
- A second accessory conduit box can be provided in addition to item 2. For two separate accessory conduit boxes, add \$2,254 to the list price. Note: Second accessory box is not available on 5008 Frame Hazardous Location motors.
- For a single oversized accessory conduit box with terminal strip connectors and the capability to terminate up to three external accessories (bearing RTDs, vibration detectors, etc.), add \$2,254 to the list price. To prewire external accessories to this box, add \$235 to the list price.
- An accessory conduit box supplied with winding RTDs or thermocouple includes leads prewired to a terminal strip for ease of customer connection at no charge. To add terminal strip connection when RTDs are not included, add \$258 to the list price.
- NEMA Type I conduit box (terminal housing). Nidec Motor Corporation's standard conduit box meets or exceeds the volume requirements of a NEMA Type I (Table 20-3) conduit box. Cover-to-box and box-to-frame are gasketed.
- NEMA Type II conduit box. To modify a standard main conduit box arrangement to NEMA Type II volume requirements, along with standoff insulators with copper buss bar lead connectors and a ground lug, add as follows:

FRAME	MOTOR VOLTAGE		
	460/600	2300/4800	6000/6900
449/5000	\$5,500	\$6,876	---
5800	\$5,500	\$6,876	\$13,352
6812 (TE)	\$5,500	\$6,876	\$13,352
6800	---	\$6,876	\$13,352
8000	---	\$6,876	\$13,352
9600	---	\$6,876	\$13,352

*Refer to Inquiry Group for availability on 6600/6900 volts.



† All marks shown within this document are properties of their respective owners.

MODIFIABLE PRICING INSTRUCTIONS

CONDUIT
BOX
COUPLINGS

8. CONDUIT BOX ARRANGEMENTS (continued)

B. TITAN® FRAME (449-9600)

8. For a space heater installed in a size 4.5 , 6 or 8 main conduit box, add \$2,864 to the list price. This includes a conduit box termination off main box with 3/4" A-A.
9. For a lead positioning gasket, add \$223 to the list price.
10. To provide a hinged front cover to a size 4.5 , 6 or 8 conduit box, add \$1,016 to the list price. To include a key lock (2 keys), add \$516 to the list price.
11. Buss bar terminal connection -- to add three standoff insulators to size 4.5 , 6 or 8 conduit boxes, add \$4,178 to the list price. For two-speed, two-winding motors, double adder. Requires size 4.5 or larger conduit box adder.
12. Phase segregated conduit box arrangements are not available.

Caution: This accessory is not intended for use on hazardous location motors without approval of the Inquiry Group and the addition of a special oversized hazardous location conduit box. When approved, add \$39,366 LIST FOR ONLY THE CONDUIT BOX UPGRADE REQUIRED FOR HAZARDOUS LOCATION MOTORS. This option will extend delivery. This option is only available on motors with a maximum full-load current of 600 AMPS, 449 frame and larger.

The quick-disconnect/separable connector offering includes the apparatus bushing and connector kit. When ordering this option, the following information must be supplied:

- a) Number of power feeder cable per phase
- b) Cable size
- c) Cable construction -- solid or stranded
- d) Type of cable shielding
- e) Diameter of the cable insulation (not the cable jacket)

To include this accessory with frame sizes of 449TP and larger, add \$11,197 to the list price, which includes an oversized conduit box and three connectors. For motors with multiple leads per phase, add \$7,824 to the list price for each additional set of three connectors. If other accessories will be mounted in the main conduit box, make the appropriate accessory and conduit box adders.

9. COUPLINGS

A. HOLLOSHAFT® MOTORS

All vertical HOLLOSHAFT® motors described in this catalog include a specialized drive coupling mounted at the top of the motor. The coupling bore diameter (BX dimension) must be closely matched to the diameter of the pump head-shaft. Each frame series has a variety of BX dimensions available. These can be found in the dimension print section on page E-3-E-5. Customers who do not order a nonreverse ratchet can select from two methods of fastening the drive coupling to the motor.

- Pinned drive couplings are used to prevent the pump line shaft from completely unscrewing in the event of a power failure or phase reversal. Should the pump spin fast enough in reverse to begin to unscrew the shafting, the drive coupling will lift up off its pins and spin with the pump shaft. This is known as a self-release coupling (SRC).
- Bolted drive couplings are used when the upthrust conditions exist. This method prevents the drive coupling from becoming disengaged from the motor (lifting off its pins) during upthrust. The bolted coupling arrangement offers no reverse rotation protection. If this is required, the customer should order a nonreverse ratchet (NRR) described in item 25 on page M-39.



† All marks shown within this document are properties of their respective owners.

MODIFIABLE PRICING INSTRUCTIONS

COUPLINGS
CURRENT

9. COUPLINGS (continued)

B. SOLID SHAFT MOTORS

Nidec Motor Corporation does not supply a coupling on this product; the customer must furnish their own coupling.

10. CURRENT TRANSFORMERS FOR DIFFERENTIAL PROTECTION

A healthy motor maintains the same magnitude of current flowing in and out of each phase of its winding. A breakdown in the insulation system alters this balance, resulting in a measurable difference when the current flowing in and out of each circuit is compared for symmetry. Any dissimilarity within an individual circuit is known as differential current and can be detected with current transformers that provide differential protection.

Differential protection is accomplished by bringing out both ends of the winding into the main motor conduit box. Both leads of each circuit pass through the center of a dedicated window-type current transformer. In a self-balancing system, the 3 CTs are located at the motor. When a fault is detected, a signal is sent to a relay (not provided by Nidec Motor Corporation) in the switchgear, taking the motor offline.

An alternate system includes 3 additional CTs in the switchgear and is commonly known as a conventional system. In most cases, the switchgear OEM provides all 6 CTs since their characteristics must be closely matched for maximum protection.

The conventional system provides a greater zone of protection (motor and cable run). However, it is significantly more expensive and less sensitive than the self-balancing method since it requires a higher fault current to trip the relay.

A. PRICING OF CURRENT TRANSFORMERS

- Available on frame sizes 449 through 9608
- For 2 winding multispeed motors, double list price adder

WINDOW TYPE CTs -- For a quantity of 3 window-type (typically type IMC 50:5 ratio) current transformers supplied and mounted by Nidec Motor Corporation, add as follows:

460 - 4800 volts \$8,554 list
5000-6900 volts \$11,103 list

MOUNTING ONLY -- Nidec Motor Corporation will mount customer-supplied current transformers for \$2,331 list each. This requires a complete description and a dimension print of supplied accessory.

- Do not apply to hazardous location motors without mandatory Inquiry Group approval*
- Required oversize main conduit box **is not included** in these list-price adders

**Hazardous location use requires a special oversized main conduit box and mandatory approval by the Inquiry Group. When approved, the price for this special conduit box only is \$37,089 list.*



MODIFIABLE PRICING INSTRUCTIONS



11. DRAINS AND BREATHERS

Standard enclosed-frame products described in this catalog include drain holes in the low point of the bracket to prevent condensation buildup. Optional drain and breather elements are available and will be installed by Nidec Motor Corporation for the following list prices. CORRO-DUTY® and severe-duty motors include the first option as standard.

MOTOR ENCLOSURE	DESCRIPTION OF DRAIN AND BREATHER	LIST PRICE
TEFC	DRAIN HOLE-BRASS BREATHER DRAIN	\$178
TEFC/HAZARDOUS LOCATION (CLASS I, GROUP D)	STAINLESS-STEEL DRAIN	\$270

12. EFFICIENCY

- Available on NEMA and TITAN® products
- Some other modifications listed in this catalog, when incorporated into a product with this option, will reduce published efficiency levels (altitude, ambient, extra high thrust, etc.)
- Inverter-duty motors require this option

Nidec Motor Corporation offers enhanced efficiency products that feature design optimization and premium grade materials. We recognize your need for increased motor performance is driven by the potentially significant operational cost savings associated with enhanced motor efficiency. Your power costs savings are determined by a number of factors (depending on which payback method you select), including the cost of power and hours of operation. Because not all motors run 24 hours a day, 7 days a week, we offer three prepriced efficiency options for NEMA frame motors and two efficiency options for TITAN® products.

Certain modifications (high altitude, abnormal ambient temperature, 50HZ or other frequency, extra high thrust bearing arrangements lower than standard temperature rise, multispeed products, copper bar rotors, low noise designs, etc.) will cause motor performance to vary from stated values. Individual modifications that have the tendency to impact motor performance are noted in their description. Individual modifications that have the tendency to impact motor performance are noted in their description. Should any question exist, refer to the Inquiry Group.

Vertical motors are inherently different from their horizontal counterparts. Possible efficiency levels for horizontal motors do not always translate well into the vertical form. One reason for this is their ability to withstand significant thrust loads imposed on the motor by the pump. This is accomplished in the motor by the use of specialized bearing arrangements that generate additional losses. Nidec Motor Corporation factors these thrust-bearing losses into our efficiency calculations to provide the most accurate data possible.

Increasing bearing capacity reduces motor efficiency. If extra high thrust (175%, 300% or above) is selected for either actual pump thrust conditions or extended bearing life requirements, efficiency should be reduced. The following chart illustrates the additional losses associated with the use of extra high thrust angular contact, spherical roller and plate type bearings. For precise efficiency values when extra high thrust arrangements are used, refer to the Inquiry Group.



MODIFIABLE PRICING INSTRUCTIONS

EFFICIENCY

12. EFFICIENCY (continued)

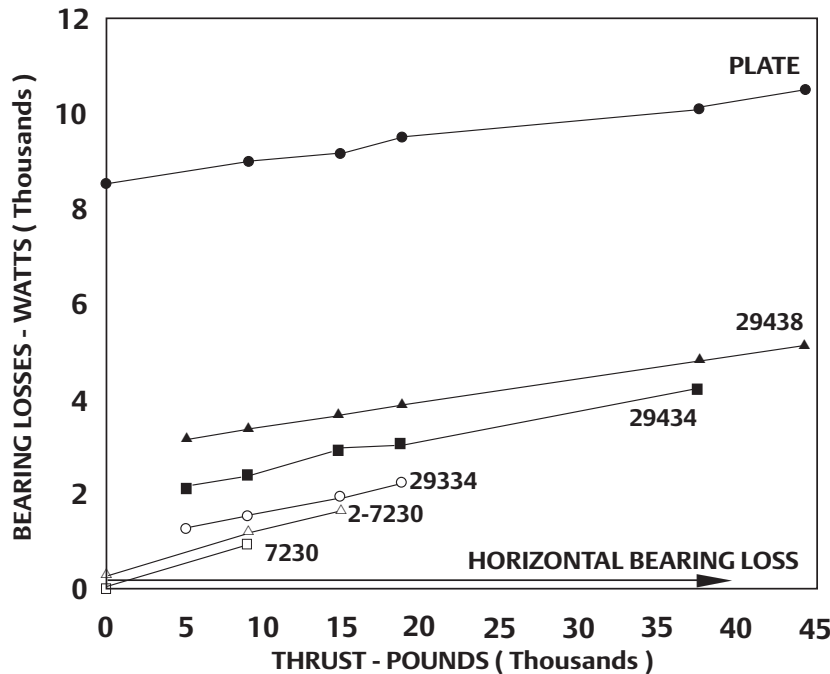

VERTICAL BEARING LOSS COMPARISON

Bearing Reference:

- 7230 -- Angular Contact Bearing (2-7230 Require Quantity 2 7230)
- 29334, 29434, 29438 -- Spherical Roller Bearing
- Plate Bearing

The above illustration compares the bearing losses (in watts) of various vertical high and extra high thrust capacities to the bearing losses for a typical horizontal motor. Note that incrementally increasing thrust bearing capacity to facilitate longer bearing life or pump thrust load produces higher bearing losses. Higher bearing losses reduce motor efficiency.

PAYBACK ANALYSIS

A number of methods are available to evaluate the potential cost savings obtained by premium efficiency motors. Nidec Motor Corporation sales engineers will be happy to assist you and apply some of the more rigorous tests that include the time value of money at various yield rates. However, you may want to get a general idea of the benefits possible, and this can be accomplished by the simple payback method (shown below). This provides annual power cost savings when the following items are known: Your cost / kilowatt hour of power, actual hours of operation and the full load efficiency level of a standard vs. premium efficiency motor.

$$S = .746 \times \text{HP} \times C \times N \left[\frac{100}{\text{SE}} - \frac{100}{\text{PE}} \right]$$

Where:

- S = Energy savings / year @ 100% load
- C = Energy costs \$/ KWH
- N = Hours / years running time
- SE = Standard efficiency product at full load
- PE = Premium efficiency product at full load



† All marks shown within this document are properties of their respective owners.

MODIFIABLE PRICING INSTRUCTIONS



12. EFFICIENCY (continued)

SIMPLE PAYBACK ANALYSIS EXAMPLE

RATING: 125HP - 1800 RPM - 460V
POWER COST: 5 cents per KW hour
OPERATION: Continuous duty - 8760 hours / year
PRODUCTS: Standard Efficient 93.0% @ F/L
Energy Efficient 94.1% @ F/L
Premium Efficient 95.4% @ F/L

ENERGY EFFICIENT

$$S = .746 \times 125 \times .05 \times 8760 \left[\frac{100}{93.0} - \frac{100}{94.1} \right]$$

$$S = 40843.5 [1.075269 - 1.062699]$$

Annual power cost savings (energy efficient) = \$513.39

- Substituting a premium efficient product with 95.4% F/L efficiency for the energy efficient motor produces an annual power cost savings of \$1,104.85
- The difference in **LIST** price between the standard efficient (type RU) and energy efficient (type RUE) is \$1,337. Payback for this **LIST** price premium is 2.6 years
- For the premium efficient (type RUS) the difference in **LIST** price is \$2,144. The payback based on this **LIST** price difference is 1.9 years.
- When you compare your actual **net** cost differences to the above illustrations this becomes a very attractive option.

EFFICIENCY LIST PRICE ADDERS

NEMA[†] FRAME -- All three efficiency options are shown pre-priced in the modifiable motor section for your convenience.

TITAN[®] PRODUCTS -- Premium Efficiency motors are pre-priced in the Modifiable Motor section for your convenience.



MODIFIABLE PRICING INSTRUCTIONS

ENCLOSURES

13. ENCLOSURES

A. WEATHER PROTECTED TYPE I (NEMA WPI)

All open-type vertical motors offered by Nidec Motor Corporation feature a NEMA[†] WPI enclosure as standard. It is designed to minimize the entrance of rain, snow and airborne particles while protecting the internal components. It is also designed to prevent a 3/4-inch diameter rod from passing into the motor. A unique feature of Nidec Motor Corporation's WPI design is the motor's air flow pattern. Cooling air is drawn through the motor and exhausted in such a way to avoid drawing any pumped fluids into the motor, should the pumps packing seal or mechanical seal fail. Further, corrosion-resistant screens and grills cover all opening, preventing snakes, rodents, etc., from entering the motor. This is our standard product for outdoor service.

B. WEATHER PROTECTED TYPE II (NEMA WP II)

- Available only in frames sizes of 449 through 9600
- For WP II protection in smaller frame sizes, use TEFC

The same construction features described for the WPI motor are further refined to include protection against high velocity winds, severe storms, such as hurricanes, and airborne particles from entering directly into the electrical package of the machine. The cooling air intake velocity is reduced to 600 ft/min (maximum) and must make at least three 90° right angle turns before passing into the cooling circuit. Any contaminants entering the motor (dirt, dust, abrasives, etc.) are trapped into chambers at low points in the enclosure with clean-out ports for easy maintenance.

This product is often applied to wet, corrosive, contaminated environments commonly found in heavy industries such as pulp and paper, electric utilities, petro-chem and steel mills as well as many municipal installations. Construction features include cast iron and heavy-fabricated steel, CORRO-DUTY[®] internal and external protective treatments and provisions for air filters. **Space heaters are also furnished at no charge if specified at order entry.** All form-wound coil machines receive two complete cycles of 100% solids epoxy VPI. For WP II enclosures, add per list price as shown below.

FRAME SIZE	449	5000	5800	6800	8000	9600
WP II ENCLOSURES	\$15,365	\$17,606	\$26,408	\$41,815	\$41,815	\$52,230

C. CORRO-DUTY[®] WITH WPI OR WP II ENCLOSURES

- WPI motors -- CORRO-DUTY[®] paint and coatings are available (but not in all cast-iron construction) for WPI motors. Should a customer require CORRO-DUTY[®] internal and external protective treatments, add for Insulife 2000, 3% for paint and coatings, and for cast-iron conduit box.
- WP II enclosures -- CORRO-DUTY[®] treatments are standard on WP II motors.



MODIFIABLE PRICING INSTRUCTIONS

ENCLOSURES

13. ENCLOSURES (continued)

D. AIR FILTERS

- Available only on WP11 enclosures

Removable dry-type air filters are available for use only on WP11 motors. These have a zinc filter media on 449 through 5813 and polyurethane on 6800 and larger that provides a high dust holding capacity. These are easy to clean, and replacements are readily available. Disposable air filters are not recommended. Alternate filter media are not available. For air filters on WP11 motors, add per list price shown on next page.

ITEM	FRAME SIZE					
	449	5000	5800	6800	8000	9600
STD AIR FILTERS	\$2,507	\$2,507	\$2,507	\$2,507	\$2,507	\$2,507
STAINLESS STEEL	\$5,500	\$7,242	\$9,880	\$25,822	\$28,873	\$35,915

E. AIR FILTER DIFFERENTIAL PRESSURE SWITCH

- Available only for WP11 enclosures

When this accessory is applied to WP11 motors with air filters, it guards against clogged filters that can starve the motor from cooling air. Air filters remove a wide variety of airborne particles. The concentration of these particles can vary greatly from hour to hour, week to week, season to season. Due to these fluctuations, using a preset time schedule can be an uncertain gauge of air filter condition. A widely accepted method of determining air filter condition is to measure the pressure drop across the air filters. This is accomplished with an accessory that allows the filter to be used until its maximum dust holding capacity is reached.

FRAME SIZE	449	5000	5800	6800	8000	9600
AIR PRESSURE DIFFERENTIAL SWITCH	\$1,676	\$1,676	\$1,676	\$1,676	\$1,676	\$1,676

F. AIR TEMPERATURE SENSOR

- Available only in WP11 enclosures

A resistance temperature detector (RTD) can be supplied in the air flow inlet of WP11 motors to monitor incoming air temperature. Winding RTDs should be provided when this option is specified. The RTD monitoring the air flow should be the same rating as the winding RTD and will be wired to the same auxiliary terminal box.

FRAME SIZE	449	5000	5800	6800	8000	9600
AIR TEMPERATURE SENSOR	\$1,897	\$1,897	\$1,897	\$1,897	\$1,897	\$1,897

G. TOTALLY ENCLOSED FAN COOLED (TEFC)

- Available only in 182 through 6812 frame sizes
- Also used for WP11 requirements in NEMA^{®†} frame (182 through 449) size motors
- Standard TEFC motors have a 1.0 service factor -- except as shown in this catalog
- 1.15 SF may not be available on maximum ratings in some frame sizes



† All marks shown within this document are properties of their respective owners.

MODIFIABLE PRICING INSTRUCTIONS



13. ENCLOSURES (continued)

G. TOTALLY ENCLOSED FAN COOLED (TEFC)

Unlike WPI or WPIL enclosures, TEFC enclosures do not allow a free exchange of air to take place between the external environment and internal motor components. Heat generated by the motor is dissipated when the external fan forces cool air over the surface of the frame and end brackets. TEFC motors are widely applied to dust laden, abrasive and corrosive environments where maximum internal component protection is required.

Since there is no free exchange of air, TEFC motors can be susceptible to internal condensation. Areas of high humidity or where great swings in day to night temperatures frequently occur can experience internal condensation. Additionally, TEFC motors applied to intermittent-duty loads can be prone to condensation as the heating (run time) and cooling (down time) cycles tend to draw moisture into the motor as it cools down and remains idle. For TEFC installations concerned with condensation buildup, Nidec Motor Corporation suggests the addition of space heaters, drain and breather elements (all Nidec Motor Corporation TEFC motors have drain holes in the low point of the motor) and on a case-by-case basis, possibly oil sump heaters. Another concern of condensation-prone areas can be overhead feed of metal conduit to the TEFC motor. It is not uncommon for condensation to build up in the metal conduit, drain into the motor conduit box, and cause a failure. Where this is a concern, Nidec Motor Corporation recommends potting of the motor leads, and a conduit box drain/breather in the box cover. This option is not available on 182 through 286 vertical TEFC motors that are not CORRO-DUTY® or severe-duty products. Requires a cast-iron or fab-steel conduit box as well.

LIST PRICE ADDERS

FRAME	182/286	324/365	404/447	449/6800(2)
POTTED LEADS	\$235 ⁽¹⁾ PLUS 10%	\$352	\$469	\$735
CONDUIT BOX DRAIN AND BREATHER	\$235	\$235	\$293	\$441
CAST IRON CONDUIT BOX	10% ⁽¹⁾	\$293 / \$469 (360)	\$587 / \$704 (440)	STD
SPACE HEATER	\$300	\$385	\$385	\$1,657 / \$1,819 (5800)
BRACKET DRAIN AND BREATHERS	\$178 BRASS		\$270 STAINLESS STEEL	

NOTES: (1) 10% provides C.I. construction in these frame sizes
(2) Potted leads not available on 449 Frame

H. HEAVY DUTY TEFC (182-447 FRAMES, TEFC ONLY)

Standard designs of the TEFC motors described in this catalog are supplied with a 1.0 SF except the premium efficient "S" version TEFC motor, which is Class B rise at 1.0 and Class F at 1.15. To add 1.15 SF where products are standard as 1.0 S.F., add 5% to the list price. Standard materials of construction will not change.

I. CORRO-DUTY® TEFC (182-6812 FRAMES)-- AVAILABLE WITH ALL EFFICIENCY OPTIONS

CORRO-DUTY® is the industry standard for heavy duty, corrosive environments. It consists of all cast-iron construction, 1.15 SF, specialized internal and external protective treatments, treated rotor, ground lug in double gasketed conduit box, noncorrosive drain and breather, and a stainless-steel nameplate. To include these features, add as follows:

- TEFC motors 182-447 frame, add 10% to the standard efficient list price.
- TEFC motors 449-6812 frame with cast-iron frame, end brackets, conduit box and heavy fabricated steel fan cover guard add 6% to the standard or premium list price. To include cast-iron fan cover guard, add 8% to the standard or premium list price. (cast-iron fan cover N/A on 5812 or 6812)
- Hazardous Location motors 182-5811 frame, add per above, plus service factor if required.



† All marks shown within this document are properties of their respective owners.

MODIFIABLE PRICING INSTRUCTIONS



13. ENCLOSURES (continued)

J. 841 PLUS® Modifications

Totally enclosed fan cooled vertical solid shaft motors can be provided with 841 PLUS® Modifications. The following features will be included:

- Premium Efficiency
- Corro-Duty® cast iron construction
- Inpro\Seal® on shaft extension end
- 1.15 Service Factor
- Ground Lug in Conduit Box
- Ground Terminal on Frame
- Class F insulation with 80°C rise at 1.0 Service Factor (Resistance Method)
- Special Balance
- Special Shaft Run-out
- Oversized Main Conduit Box
- NEMA Design B
- Non-witnessed IEEE 841 Enhanced No Load Test
- 841 PLUS® MODIFICATIONS nameplate
- 50,000 hr bearing L-10 life (Thrust must be provided to confirm bearing life)
- Special 3 year warranty

To provide the above features, make the following list price addition to the Premium Efficiency motor base list price

Frame	182 184	213 215	254 256	284 286	324 326	364 365	404 405	444 445	447	449	5000	5800	6812 (TE)
Adder	\$1,000	\$1,500	\$2,000	\$2,500	\$3,900	\$4,734	\$5,666	\$6,702	\$7,790	\$11,620	\$12,290	\$13,238	\$18,670

*Contact the Inquiry Group for a complete list of specification exceptions and/or features available on vertical HOLLOSHAFT® motors.

**Please ask for optional special adders available on some frames sizes, such as: Everseal®† on medium voltage, bronze fan, painted aluminum fan, and sound abate fan cover.

***Does not apply to Normal thrust C-Face motors

K. HAZARDOUS LOCATION

- Available only in 182 through 5811 frame sizes
- 1.0 service factor is standard
- Not all accessories and modifications are available with this enclosure
- Hazardous location pricing is shown as an adder to the basic TEFC motor in the modifiable section
- 1.15 SF may not be available on maximum HP ratings in specific frame sizes

DIVISION 1 HAZARDOUS LOCATION (UL LISTED)

- Motor normally exposed to contaminated environment
- For T2D or T3C temperature code, add thermostats to Hazardous Location pricing

The Hazardous Location motor is a totally enclosed motor designed to withstand a hazardous ignition of a specified gas or vapor inside the motor casing and prevent the ignition outside the motor by sparks or flashing. Nidec Motor Corporation's motors are UL-approved for Class 1 (gas or vapor), Group D, which includes gasoline, hexane, naphtha, benzene, butane, propane, alcohol, lacquer solvent vapors and natural gas. Ignition temperature vs. temperature marking indicates a maximum temperature for all conditions including overload, locker rotor, singled phasing and burnout. When ordering, indicate class, group and temperature code requirements. See pricing of Hazardous Location motor on base TEFC motor pricing pages.

HAZARDOUS LOCATION CLASSIFICATION	MAXIMUM SURFACE TEMPERATURE	TEMPERATURE CODE
CLASS I, GROUP D	260°C	T2B



† All marks shown within this document are properties of their respective owners.

MODIFIABLE PRICING INSTRUCTIONS

ENCLOSURES

13. ENCLOSURES (continued)

K. HAZARDOUS LOCATION

ENCLOSED DIVISION 2 HAZARDOUS LOCATION (UL LISTED)

- Motor is abnormally or accidentally exposed to contaminated, hazardous environments.

Division 2 is the abnormal situation. Material is expected to be confined within closed containers or closed systems and will be present only through accidental rupture, breakage, or unusual faulty operation. Use hazardous location list adder times 0.90 multiplier for determining Division 2 list adder. Accessories must be hazardous location for UL-listed items. Listed Division 2 is not available on open machines.

DIVISION 2 SELF-CERTIFIED (NON-UL LISTED)

The National Electrical Code Section 501.125(B) allows the installation of open or non-hazardous location enclosed motors without brushes, switching mechanisms or similar arc-producing devices in Class I, Division 2 locations. Nidec Motor Corporation can supply self-certified motors meeting the NEC requirements under normal operating conditions (full load). These motors are available for Class I, Group A,B,C, and D with temperature codes T1 through TC3, with some restrictions. To provide a motor meeting requirements of the NEC, add 2% of the motor's total list price.

Self-certified restrictions:

- Not applicable to hazardous location motor
- Single speed only
- 40°C ambient, 3300 feet altitude
- Use hazardous location adders for all accessories. Accessories not available on Division I hazardous location motors are not available on Division 2 motors.
- Inverter duty is available with temperature codes T1 through T3 only. Motors are limited to 1.0 SF on inverter power. Hermetically sealed thermostats will be provided.

L. UL® LISTED FIRE PUMP

UL® Listed fire pump motors are designed per UL-1004-5 and meet the NFPA-20 "Standard for the Installation of Centrifugal Fire Pump Specifications." Nidec Motor Corporation's UL®-Listed Fire Pump motors meet the special design requirements listed below:"

- Designed to meet NEMA Design "B" limitations per NEMA MG1
- Applies to motors rated 500 HP or less, 600 volts or less and frames 5813 and less.
- Calculated Safe Stall Time must exceed 12 seconds (cold)
- Motors designated for Canada must meet CSA-390 Table 2 efficiency values.
- Add 5% of base list price for Fire Pump Service

14. EXPORT BOXING (also used for domestic crating requirements)

Export packaging is available from our international warehouse in Southaven, MS. Material used to export box vertical motors is 2 x 4s for the frame and 1/2" plywood for walls. The conduit box is removed and placed in a box with the motor. Shipping marks are stenciled to the outside of the box. For other options, such as gangboxing and containerization, contact Nidec Motor Corporation.

Pricing: 6% NEMA[†] list
3% TITAN[®] list
\$150 minimum NET charge each motor

NOTE: Motors for use on vertical turbine pumps require a NRR.



MODIFIABLE PRICING INSTRUCTIONS

EXPORT
INSULATION

15. FREQUENCY

Motors listed in this catalog are 60 cycle as standard. 50-cycle motors are available from production as follows:

- If motor has 1.15 SF and customer wants 50HZ with 1.0 SF -- no charge
- If motor has 1.15 SF which customer wants 50Hz 1.15SF -- add 10% list
- If motor has 1.0 SF and customer wants 50HZ 1.0 SF -- add 10% list
- If motor has 1.0 SF and customer wants 50HZ 1.15 SF -- add 10% list plus 1.15 SF adder

Provisions for Wye-Delta starting are no charge if noted at time of order entry.

16. GROUNDING PROVISIONS (FRAME)

Add \$352 list for a bronze bolt (GT) on the motor frame (180 through 400 frame) or \$441 list for a ground pad (GP) on the motor frame (440 frame and larger). Ground pads are not available below the 440 frame.

Add \$549 list for a ground pad on hazardous location motors, 440 frame and larger (includes a conduit box ground lug).

17. HORSEPOWER, NON NEMA-STANDARD RATING

A non-standard horsepower rated motor can be designed. Refer to the Inquiry Group with application details. Price using list price of next-higher horsepower rating for same motor type. Motors can be nameplated in KW units. For list price determination, divide KW by .746 to figure equivalent horsepower.

18. INSULATION CLASS

- All products described in this catalog are manufactured with copper magnet and lead wire. Aluminum wire is not available.
- All production-modified products are supplied with Class F insulation as standard.
- Inverter-duty products are supplied with a special insulation system that is described in item 19 on page M-34 of this section.
- Class H insulation is an available option for inverter-duty products with our specialized insulation system.
- Temperature-rise considerations are described in item 46 on page M-66 of this modification section.

INSULATION CLASS

Common designations include Class B, F, and H. These indicate the maximum thermal capability of each system based on providing a life expectancy in accordance with IEEE guidelines and industry standards. The following table illustrates the various elements and their contribution to the insulation systems.



MODIFIABLE PRICING INSTRUCTIONS



18. INSULATION CLASS (continued)

**REFERENCE TABLE
CLASSIFICATION OF INSULATION**

INSULATION CLASS	A ^①	B	F	H
Ambient temperature (for options see item 3 on page M-5)	40°C	40°C	40°C	40°C
Temperature rise at nameplate H.P. (for options see item 46 on page M-68)	60°C	80°C	105°C	125°C ^②
Hot spot or service factor allowance (for service factor see item 37 on page M-53)	10°C	10°C	10°C	15°C
Thermal limit of insulation system ^③	105°C	130°C	155°C	180°C
NOTES: ① Class A insulation is shown for reference only and is not commercially available from Nidec Motor Corporation. ② Class H insulation is offered for special ambient conditions, life requirements, etc. Class H temperature rise is not available or used by Nidec Motor Corporation. ③ Each insulation class provides the same winding design life when operated at its thermal limit.				

Any deviation from insulation class standards stated on individual pricebook pages requires the appropriate modification adder and may impact frame size and performance characteristics.

AVAILABLE INSULATION SYSTEMS

CLASS	PRODUCT APPLICATION	PRICE ADDER
B	Class F with B rise @ 1.15 SF standard on all stock, WPI products in frames 182 through 445	not required
F	Class F with B rise @ 1.0 SF standard on all stock TEFC products, Stock WPI 447 frames and larger, and all modified WPI, WPII and TEFC production motors	not required
F or H (VFD)	Special INVERTER GRADE [®] Insulation system featuring pulse-resistant magnet wire with special end-turn lacing and phase paper treatments	Refer to item 19 on page M-34 of this section

CLASS H INSULATION LIST PRICE ADDER

Frame	182	213	254	284	324	364	404	444	447	449	5000	5800	6812 (TE)	6800-8000	9600
Adder	\$175	\$211	\$277	\$462	\$607	\$779	\$1,125	\$1,340	\$1,855	\$1,855	\$2,356	\$3,031	\$4,914	\$5,859	\$6,359



† All marks shown within this document are properties of their respective owners.

MODIFIABLE PRICING INSTRUCTIONS



18. INSULATION CLASS (continued)

WINDING TREATMENTS

Availability of specialized insulation treatments depends upon the coil construction used in the wound stator assembly. Guidelines for random wound and form wound coil construction are:

Random wound coils are typically used on all low-voltage (600 volts and below) motors rated 600 HP and below, 5800 frame and smaller except 2-pole.

Form wound coils are used on all motors (regardless of voltage) in the 6800, 8000 and 9600 frames and on all products rated above 600 volts. Nidec Motor Corporation does not manufacture medium voltage (2300 - 7000 volts) random wound products.

- Specific applications (VFD, frequent starting duty, etc.) and other design complications may require deviation from the above guidelines. Consult the Inquiry Group if questions exist.
- Form wound coils are available for some low voltage ratings traditionally manufactured as random wound. This requires approval by the Inquiry Group; when approved, price as a 2300 volt motor.
- Nidec Motor Corporation reserves the right to modify these guidelines as required.

SELECTION TABLE

WINDING TYPE		
INSULATION CHOICE	RANDOM WOUND	FORM WOUND
Insulife 1000	STD	N/A
Insulife 2000	OPT	N/A
Insulife VPI 1000	OPT*	N/A
Insulife VPI 2000	OPT**	N/A
Abrasion Resistant	OPT	---
Insulife VPI 5000	N/A	STD
Premium Everseal	N/A	OPT
Abrasion Resistant	---	OPT

*Standard on random wound TITAN® motors in 449 frame and larger.

** Standard on 500 through 700 horsepower, random wound, low voltage TITAN® motors.



MODIFIABLE PRICING INSTRUCTIONS



18. INSULATION CLASS (continued)

DESCRIPTION OF AVAILABLE INSULATION TREATMENTS

- **INSULIFE 1000** -- Standard treatment for 182 through 447 frames. Insulife 1000 utilizes 100% solid polyester resins completely impregnating slot and end turns. The standard insulation material is non-hygroscopic Class F (155°C), suitable for WP-1 motors in a relatively dry environment or for a TEFC motor with moderate exposure to moisture. One dip and bake in polyester resin.
- **INSULIFE 2000** -- An additional treatment of polyester varnish ideal for applications with high moisture content, such as tropical environments for fungus resistance. Two dips and bakes. Standard on CORRO-DUTY® motors.
- **INSULIFE VPI 1000** -- One cycle of vacuum pressure impregnation of 100% solid epoxy resins. Available on 320 through 440 frames as an option. Cast-iron construction only. Standard on TITAN® motors with 600 volt maximum insulation (random wound).
- **INSULIFE VPI 2000** -- Two cycles of vacuum pressure impregnation with 100% solid epoxy resins. Meets NEMA definition for moisture-resistant winding per NEMA MG1 - 1.27.1.
- **INSULIFE VPI 5000** -- Two cycles of vacuum pressure impregnation. Standard process on TITAN® frame 2300 volt and up motors. Provides 7 mils Insulation Build -- 3 cycles are not available.
- **PREMIUM EVERSEAL®† (SEALED)** -- Two cycles of VPI with the connection end receiving a special sealing treatment. Premium EVERSEAL®† provides additional strength and deflection protection to winding end turns. For form wound motors only. Meets requirements for “sealed” per NEMA MG1-1.27.2, spray test per NEMA MG1-20.18, or immersion test.
- **Abrasion Resistant** -- Optional overcoat treatment available on any of the above systems. Protects against environments contaminated with abrasive dust such as fly ash, cement dust, etc. Highly resistant to all environmental forms of abrasion.

LIST PRICE ADDERS FOR NEMA®† FRAME OPTIONS

INSULATION OPTION	182 184	213 215	254 256	284 286	324 326	364 365	404 405	444 445	447
INSULIFE 2000	\$80	\$127	\$162	\$270	\$345	\$425	\$570	\$742	\$742
VPI 1000	NA	NA	NA	NA	\$1,714	\$2,019	\$2,847	\$3,887	\$3,887
VPI 2000	NA	NA	NA	NA	\$3,427	\$4,038	\$5,695	\$7,775	\$7,775 *
ABRASION RESISTANT	\$80	\$127	\$162	\$270	\$345	\$425	\$570	\$742	\$742

LIST PRICE ADDERS FOR TITAN® FRAME OPTIONS (449 TROUGH 9600 FRAME)

FRAME SIZE	449 5000	5800	6812 (TE)	6800-8000	9600
INSULIFE VPI 2000	3%	3%	N/A	N/A	N/A
EVERSEAL®:					
WPI, WPII	5%	5%	N/A	5%	5%
TEFC	2.5%	3%	5%	N/A	N/A
ABRASION RESISTANT	1%	1%	1%	1%	1%

*No change on 300HP and larger.



† All marks shown within this document are properties of their respective owners.

MODIFIABLE PRICING INSTRUCTIONS



19. INVERTER DUTY

- This modification will alter published performance characteristics when motor is operated on non-sinusoidal waveforms.

The application of vertical motors to variable torque pump loads is an ideal candidate for process control through the use of a variable frequency drive (VFD). Significant operational cost savings are possible in many pumping systems.

Advances in microprocessors and power semiconductor technology have evolved to improve the performance, reliability and cost attributes of VFDs. This evolution has occurred over a 30 year period. With each power semiconductor milestone achieved, drive switching frequency increased.

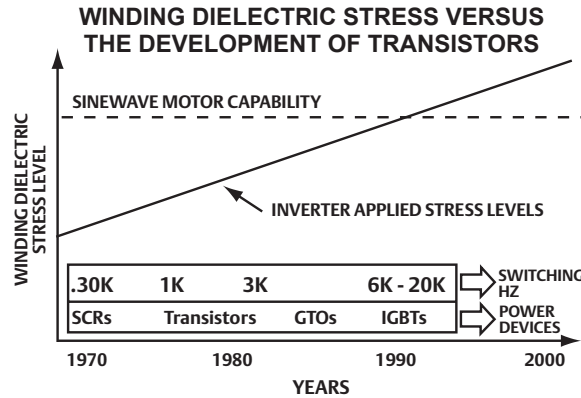

Increased switching frequency has created new challenges for existing insulation systems. Electric motor insulation systems have, for the most part, not changed in 30 years. It is no longer accurate to think that inverter-driven motors only have a thermal problem -- one which can be solved by using a premium efficiency motor. Today's drives produce a high rate of rise voltage waveforms that impose high impulse electrical stress on the motor insulation. Unfortunately most current insulation life standards do not specify the maximum repetitive voltage transients, the switching frequency (kHz), and rate of rise that the winding should be able to withstand and still maintain normal life expectations. Standard insulation systems are not designed to operate in this new electrical environment, and when they are, unpredictable motor performance is the result.

Nidec Motor Corporation was the first motor company to recognize this by introducing the first formal INVERTER GRADE® Insulation System. This system provides protection against the effects of IGBT power devices through the use of additional phase paper end-turn bracing as well as pulse resistant magnet wire. The benefit was clear: Under inverter fed applications, a significant improvement in winding life was achieved. Nidec Motor Corporation's INVERTER GRADE® Insulation System meets the stringent requirements outlined in NEMA MG-1, Part 31.

Service factor - Sine wave vs VFD power: Motors will be rated 1.15SF on sine wave and 1.0SF on VFD power. Inverters add harmonics to the waveform, which produce additional heat. Running the motor at 1.0SF while on the inverter assures that the winding temperature limits are within the insulation temperature capabilities.

Over-speed on VFD rated units: Motors will be capable of over-speed per NEMA MG1 12.53.2. Note, even though motors are mechanically capable of over-speed, the pump will overload the motor if ran in over-speed.



† All marks shown within this document are properties of their respective owners.

MODIFIABLE PRICING INSTRUCTIONS

INVERTER
DUTY

19. INVERTER DUTY (continued)

Lower speed operation on VFD rated units: Nidec's non-reverse ratchet depends on centrifugal force to disengage the rotating ratchet from the stationary ratchet. When the motor is driven at very low speeds under inverter power, the centrifugal force may be insufficient to keep the ratchet disengaged and damage to the non-reverse ratchet may result. To prevent damage to the non-reverse ratchet components, the following minimum speed limits should be observed.

Frame size	Minimum speed (RPM)
182-286	500
324-5812	120
5813-8012	80
9603-9608	200

Motors with spherical roller thrust bearings require a minimum amount of down-thrust to be applied at all times to keep the bearing rollers from skidding. If a motor supplied with a spherical roller bearing is driven by an inverter, care must be taken to insure this minimum down-thrust is present over the entire speed range. Otherwise, **severe non-warranty damage will result.**

You can count on Nidec Motor Corporation to continue our design efforts aimed at maintaining a compatible product in light of advancing drive technology. We will automatically upgrade our VARIDYNE® inverter-duty product offering as technology advancements become available. For more information, contact your sales representative.

PRICE ADDITIONS FOR INVERTER GRADE® MOTORS

NEMA®† PRODUCTS IN 182 - 447 FRAME

VARIDYNE® Motors include:

- INVERTER GRADE® insulation system with pulse-resistant Class F magnet wire, heavy phase and special end-turn bracing techniques
- Low-loss electrical steel in rotor and stator
- Refined balance
- Additional insulation treatments -- Insulife 2000
- Premium efficiency
- Special dual-use nameplate with sine wave and VFD power characteristics shown
- N/C Thermostats, unless hazardous location
- Shaft grounding ring
- Insulated thrust bearing 400 Frame and larger

PRICING -- Price as premium efficiency motor and (or Energy Efficient where Premium is not available)
add 7.5% 180 - 447 Frame



MODIFIABLE PRICING INSTRUCTIONS

**INVERTER
DUTY
MARINE**

19. INVERTER DUTY (continued)

TITAN® PRODUCTS IN 449 - 9600 FRAME

VARIDYNE® Motors include:

- INVERTER GRADE® Class F insulation system
- Insulife VPI 5000 -- form wound
- Insulife VPI 2000 -- random wound
- Refined balance
- Shaft grounding ring
- Insulated thrust bearing
- Premium efficiency
- Special dual use nameplate
- N/C Thermostats unless other thermal protective devices are ordered

PRICING -- Price as premium efficiency motor and add 5%.

20. LEADS

The standard length of our leads is six inches inside the conduit box. Adder \$500 for up to 5 Ft. longer than standard -- single voltage only. For dual voltage, double adder.

21. MARINE MOTORS

CORRO-DUTY® motors meet IEEE 45 specifications, both above and below deck, in both enclosed and hazardous location enclosures. Add an Inpro/Seal®† for above deck service. Open motors are approved for below deck. When high-thrust motors are located onboard ship, bearing lubrication may be affected by the pitch and roll (1 degree maximum allowable) of the vessel. If motor is to be used as dockside transfer (not on ship/barge), use standard motor with CORRO-DUTY® features plus a space heater. For ship board applications and bow thruster drives, refer to the Inquiry Group.

NOTE: IEEE 45 requires that motors exposed to the weather, seas, splashing or other severe moisture conditions either be watertight or protected by watertight enclosures. Since electric motors "breathe" during operation, they cannot be constructed as watertight. Above-deck motors must be protected by suitable watertight enclosures

22. MULTISPEED MOTORS

- Available as single voltage ratings only
- This option will change published performance characteristics
- This option is likely to change published motor frame size
- Review product requirements with the Inquiry Group to confirm frame size and availability

Multispeed vertical motors are available for variable torque (turbine, mixed flow, propeller pumps) and constant torque (typically aerator use) applications.

2 speed / 1 winding machines are available when the no-load high speed vs. low speed RPM is a 2-to-1 speed ratio (1800/900, 1200/600 etc.).

2 speed / 2 winding machines must be used when this ratio is not 2-to-1. A completely independent winding is used to obtain the second speed. Some customers prefer to use a 2 speed / 2 winding design even though the speed ratio is 2 to 1, and they could potentially choose the lower cost 1 winding alternative.



MODIFIABLE PRICING INSTRUCTIONS

MULTISPEED

22. MULTISPEED MOTORS (continued)

COMMON MULTISPEED RATINGS - CONSTANT TORQUE

1800	1200	1800	900	1200	900	1200	600
2 WINDING H.P.		1 OR 2 WINDING H.P.		2 WINDING H.P.		1 OR 2 WINDING H.P.	
3	2.00	3	1.50	3	2.25	3	1.50
5	3.30	5	2.50	5	3.75	5	2.50
7.5	5.00	7.5	3.75	7.5	5.62	7.5	3.75
10	6.60	10	5.00	10	7.50	10	5.00
15	10.00	15	7.50	15	11.25	15	7.50
20	13.30	20	10.00	20	15.00	20	10.00
25	16.60	25	12.50	25	18.75	25	12.50
30	20.00	30	15.00	30	22.50	30	15.00
40	26.60	40	20.00	40	30.00	40	20.00
50	33.30	50	25.00	50	37.50	50	25.00
60	40.00	60	30.00	60	45.00	60	30.00
75	50.00	75	37.50	75	56.20	75	37.50
100	66.60	100	50.00	100	75.00	100	50.00
125	83.30	125	62.50	125	94.00	125	62.50
150	100.00	150	75.00	150	112.00	150	75.00
200	133.00	200	100.00	200	150.00	200	100.00
250	167.00	250	125.00	250	187.50	250	125.00

LIST ADDITIONS TO BASE HP/FRAME

CONSTANT TORQUE - ADDER TO BASE HP AT HIGH SPEED		
FRAME SIZE	182 - 447	449 - 9610
2 Speed / 1 Winding	95%	100%
2 Speed / 2 Winding	160%	160%

COMMON MULTISPEED RATINGS -- VARIABLE TORQUE

1800	1200	1800	900	1200	900	1200	600
2 WINDING H.P.		1 OR 2 WINDING H.P.		2 WINDING H.P.		1 OR 2 WINDING H.P.	
3	1.33	3	.75	3	1.68	3	.75
5	2.22	5	1.25	5	2.81	5	1.25
7.5	3.30	7.5	1.88	7.5	4.21	7.5	1.88
10	4.44	10	2.50	10	5.62	10	2.50
15	6.66	15	3.75	15	8.43	15	3.75
20	8.88	20	5.00	20	11.25	20	5.00
25	11.11	25	6.25	25	14.06	25	6.25
30	13.13	30	7.50	30	16.87	30	7.50
40	17.17	40	10.00	40	22.50	40	10.00
50	22.22	50	12.50	50	28.12	50	12.50
60	26.66	60	15.00	60	33.75	60	15.00
75	33.33	75	18.75	75	42.18	75	18.75
100	44.44	100	25.00	100	56.00	100	25.00
125	55.55	125	31.25	125	70.00	125	31.25
150	66.66	150	37.50	150	84.00	150	37.50
200	89.00	200	50.00	200	112.50	200	50.00
250	111.00	250	62.50	250	140.60	250	62.50



† All marks shown within this document are properties of their respective owners.

MODIFIABLE PRICING INSTRUCTIONS

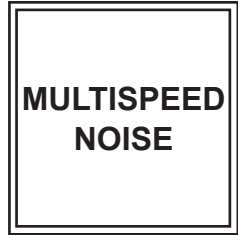

22. MULTISPEED MOTORS (continued)

LIST ADDITIONS TO BASE HP/FRAME

VARIABLE TORQUE - ADDER TO BASE HP AT HIGH SPEED		
FRAME SIZE	182 - 447	449 - 9608
2 Speed / 1 Winding	45%	60%
2 Speed / 2 Winding	130%	140%

23. NAMEPLATES, SPECIAL

- **ADDITIONAL STAMPING ON STANDARD NAMEPLATE** -- Add \$47 to the list price for stamping limited customer information on the standard motor nameplate
- **SPECIAL IDENTIFICATION** -- Where purchaser requires the company to furnish and/or mount separate special identification plates on the motor, make the list price addition for each motor of \$340 list.
- **SUPPLEMENTAL** -- Nameplates for mounting on customer equipment will be furnished at no charge when specified on original order. Note these supplemental nameplates cannot be supplied with the CSA logo.
- **ROTATION ARROW** -- add \$47 list.

24. NOISE -- TYPICAL VALUES

Typically, noise levels are quoted as dB (A) sound pressure overall. Customers normally require certain overall levels to comply with OSHA exposure levels. Example: 85 dB (A) limit for 8 hours exposure. This seemingly straightforward approach deserves severe cautions.

We are unable to include the driven equipment into our guarantee simply because we do not know how loud or how many decibels it must contribute. The surroundings can also significantly affect the observed readings. The same motor can show 6 dB(A) changes due to surroundings.



MODIFIABLE PRICING INSTRUCTIONS

NOISE

24. NOISE -- TYPICAL VALUES (continued)

NOISE LEVELS: VERTICAL MOTORS 180-9600

The following are the Nidec Motor Corporation noise levels for vertical motors. The levels are measurements in dB(A) per ANSI 12.51 and NEMA MG-1, corrected to a free field under 60 Hz sine wave power at a reference level of 0.0002 dyne/cm². These are average expected values based on no-load testing and should not be guaranteed.

FRAME	RPM	WP-I		WP-II		TEFC/XP		TEFC/XP	
		Sound Pressure	Sound Power	Sound Pressure	Sound Power	Standard & Energy Efficient		Premium Efficient	
						Sound Pressure	Sound Power	Sound Pressure	Sound Power
180	3600	70	78	n/a	n/a	75	83	75	83
	1800	60	68	n/a	n/a	65	73	60	68
	1200 & slower	55	63	n/a	n/a	60	68	60	68
210	3600	75	78	n/a	n/a	75	83	75	83
	1800	60	68	n/a	n/a	65	73	65	73
	1200 & slower	55	63	n/a	n/a	60	68	60	68
250	3600	75	83	n/a	n/a	80	88	75	83
	1800	70	78	n/a	n/a	70	78	65	73
	1200 & slower	60	68	n/a	n/a	60	68	60	68
280	3600	75	84	n/a	n/a	80	89	80	89
	1800	70	79	n/a	n/a	70	79	70	79
	1200 & slower	60	69	n/a	n/a	65	74	65	74
320	3600	75	84	n/a	n/a	80	89	80	89
	1800	65	74	n/a	n/a	70	79	70	79
	1200 & slower	65	74	n/a	n/a	65	74	65	74
360	3600	75	84	n/a	n/a	85	94	80	89
	1800	65	74	n/a	n/a	75	84	75	84
	1200 & slower	65	74	n/a	n/a	70	79	65	74
400	3600	80	90	n/a	n/a	85	95	80	80
	1800	70	80	n/a	n/a	75	85	75	85
	1200 & slower	65	75	n/a	n/a	70	80	65	75
440	3600	80	90	n/a	n/a	90	100	80	90
	1800	70	80	n/a	n/a	80	90	75	85
	1200 & slower	70	80	n/a	n/a	75	85	65	75
447	3600	n/a	n/a	n/a	n/a	90	100	85	95
	1800	85	95	n/a	n/a	80	90	75	85
	1200 & slower	80	90	n/a	n/a	75	85	70	80
449	3600	n/a	n/a	n/a	n/a	90	102	92	105
	1800	n/a	n/a	-	-	90	102	92	105
	1200 & slower	n/a	n/a	-	-	85	97	87	100
5000	3600	91	103	91	103	90	103	91	103
	1800	86	98	86	93	90	103	86	103
	1200 & slower	80	93	80	93	85	98	80	93
5800	3600	n/a	n/a	n/a	n/a	97	109	97	109
	1800	n/a	n/a	n/a	n/a	92	104	92	104
	1200 & slower	n/a	n/a	n/a	n/a	92	104	92	104
6812 (TE)	3600	n/a	n/a	n/a	n/a	n/a	n/a	n/a	n/a
	1800	n/a	n/a	n/a	n/a	92	108	92	108
	1200 & slower	n/a	n/a	n/a	n/a	92	108	92	108
6800-8000	3600	n/a	n/a	n/a	n/a	n/a	n/a	n/a	n/a
	1800	90	105	85	100	n/a	n/a	n/a	n/a
	1200 & slower	85	100	80	95	n/a	n/a	n/a	n/a
9600	3600	n/a	n/a	n/a	n/a	n/a	n/a	n/a	n/a
	1800	REFER TO OFFICE	REFER TO OFFICE	REFER TO OFFICE	REFER TO OFFICE	n/a	n/a	n/a	n/a
	1200 & slower	90	105	85	100	n/a	n/a	n/a	n/a

Measurements are reported at 3 feet for NEMA[®] frames, 5 feet for TITAN[®] frames (449 and larger). Refer to the Inquiry Group for Noise Quotation Guidelines and Octave Band Analysis Chart.



† All marks shown within this document are properties of their respective owners.

MODIFIABLE PRICING INSTRUCTIONS



24. NOISE (continued)

Sound Abatement Treatment

Sound abatement treatment is available on Titan® totally enclosed fan cooled vertical motors. The treatment provides a motor with lower than standard sound level. Use the following list price adders for this feature.

Frame:	449	5000	5800	6812
Adder:	\$3,865	\$4,400	\$5,000	\$9,550

Please contact the Inquiry Group for actual sound level data on TEFC motors and for the availability on motors with WP11 enclosure.

25. NON-REVERSE RATCHET

Our non-reverse ratchet provides immediate protection against reversing due to phase reversals or from backspin at shutdown. Nidec Motor Corporation's standard non-reverse ratchet is a ball type ratchet for counter-clockwise shaft rotation when viewed from the top of the motor. Counter-clockwise non-reverse ratchets are available wherever a non-reverse ratchet list price is shown on the corresponding motor list price page.

A special non-reverse ratchet for clockwise rotation is available for 4-pole and slower WPI units on frames 320 through 9600 and TEFC units on frames 400 through 6812.

Nidec Motor Corporation's ratchets are non-sparking and do not require special materials for hazardous location applications. The following charts provide additional non-reverse ratchet information on larger vertical motors.

VERTICAL NRR AVAILABILITY (6)

A. Open (WPI, WP11)

(4) Dir. of Rotation	449		5000		5800		6800		8000		9600	
	2P	4P & Slower	2P	4P & Slower	2P	4P & Slower	2P	4P & Slower	2P	4P & Slower	2P	4P & Slower
CCW (STD)	N/A	1	N/A	1	N/A	1	N/A	1	N/A	3	N/A	2
CW	N/A	1	N/A	1	N/A	1	N/A	1	N/A	3	N/A	2

B. TEFC and Hazardous Location (449 Frame Hazardous Location is not available) (5)

(4) Dir. of Rotation	444, 445, 447		449		5000		5800		6800	
	2P	4P & Slower	2P	4P & Slower	2P	4P & Slower	2P	4P & Slower	2P	4P & Slower
CCW (STD)	1	1	N/A	1	N/A	1	N/A	1	N/A	1
CW	N/A	1	N/A	1	N/A	1	N/A	1	N/A	1



† All marks shown within this document are properties of their respective owners.

MODIFIABLE PRICING INSTRUCTIONS



25. NON-REVERSE RATCHET (continued)

1. Ball Type
2. Pin Type
3. Ball Type is standard -- some higher thrust ratings may require Pin Type R/O.
4. Make nonreverse ratchet addition as shown for equivalent high-thrust, vertical solid shaft, totally enclosed, fan-cooled motor. Clockwise rotation where available, add to the basic NRR price \$880 list through 5811 frame \$1,761 list for 6808 and above.
5. Hazardous location NRR's are non-sparking.
6. NRR's are not available on normal thrust designs. Motors can be furnished nameplated as normal thrust and have an NRR, but it requires high-thrust construction (including oil lube) and high-thrust pricing.

26. OIL SUMP HEATERS

- Available for WPI, WP11, TEFC enclosures
- Available for upper bracket, oil-lubricated products in 320 through 9608 frame sizes with WPI enclosures, 5008 through 9608 frame with WP11 enclosures, and 447 through 6812 frames with TEFC enclosures
- Lower bracket **AND** Hazardous Location applications require mandatory Inquiry Group approval
- Please specify single phase: 115, 230, 460 or 575 volts at order entry

Oil sump heaters are recommended for applications where the ambient temperature is consistently below -5°C (23°F) and required with consistent to ambients or -15°C (5°F) and below.

LIST PRICE ADDER

Standard

Frame	182 184	213 215	254 256	284 286	324 326	364 365	404 405	444 447	449	5000	5800	6812 (TE)	6800-8000	9600
Adder	N/A	N/A	N/A	N/A	\$469	\$469	\$563	\$563	\$2,202	\$2,202	\$2,495	\$2,789	\$2,934	\$3,110

Thermostatically Controlled

Frame	182 184	213 215	254 256	284 286	324 326	364 365	404 405	444 447	449	5000	5800	6812 (TE)	6800-8000	9600
Adder	N/A	N/A	N/A	N/A	N/A	N/A	N/A	N/A	\$3,669	\$3,669	\$3,962	\$4,256	\$4,460	\$4,843



† All marks shown within this document are properties of their respective owners.

MODIFIABLE PRICING INSTRUCTIONS



27. OIL SUPPLIED WITH MOTOR

Oil-lubricated products **CANNOT** be shipped with oil in the bearing sumps. Nidec Motor Corporation **DOES NOT** offer an option to ship suitable oil (or other lubricants) with motor orders. We have selected brands that facilitate local availability and convenience for the end user. Should a question arise, please suggest one of the following products:

Nidec Motor Corporation Recommended Oil Viscosities

Angular Contact Thrust Bearing (7XXX Series)					
Motor Enclosure	Frame Size	Speed (RPM)	Ambient Temperature	ISO VG	Base Oil Type
Open Drip proof or Weather Protected	324 and larger	ALL	-15°C thru 40°C (5-104°F)	32	Mineral or Synthetic
			41°C thru 50°C (105-122°F)	68	Synthetic Only
Totally Enclosed or Hazardous Location	404 thru 447		-15°C thru 40°C (5-104°F)	32	Mineral or Synthetic
			41°C thru 50°C (105-122°F)	68	Synthetic Only
	449 thru 6812		1801 - 3600	32	Synthetic Only
			1800 & Below	68	Synthetic Only
All	41°C thru 50°C (105-122°F)	Refer to Office			
Spherical Roller Thrust Bearing (29XXX Series)					
Motor Enclosure	Frame Size	Speed (RPM)	Ambient Temperature	ISO VG	Base Oil Type
Open Drip proof or Weather Protected	444 and larger	1800 and Below	-15°C thru 25°C (5-77°F)	68	Mineral or Synthetic
			6°C thru 40°C (42-104°F)	150	
			41°C thru 50°C (105-122°F)		Synthetic Only
Totally Enclosed or Hazardous Location	449 and larger		-15°C thru 25°C (5-77°F)	68	Mineral or Synthetic
			6°C thru 40°C (42-104°F)	150	Synthetic Only
			41°C thru 50°C (105-122°F)	Refer to Office	

Notes:

1. If lower guide bearing is oil lubricated, it should use the same oil as the thrust bearing.
2. If lower guide bearing is grease lubricated, refer to TABLE 2 for recommended greases.
3. Refer to Nidec Motor Corporation for ambient temperatures other than those listed.



MODIFIABLE PRICING INSTRUCTIONS

**OVERSPEED
PAINT
PLATFORMS**

28. OVERSPEED

Percent overspeed above synchronous speed. Refer to the Inquiry Group with application details if energized or above standard speed. Standard unenergized on two poles is 20% and 25% on 4 poles and slower speeds. Applies to all thrust types.

29. PAINT

Special paint may be furnished on modified products with the prior plant approval. A special paint can be furnished if compatible with our standard primer, is commercially available, and suitable for air drying. (Zinc or lead cannot be used, and sand blasting is not available). Motors can also be supplied with just the standard primer coat at no charge, if requested at time of order. All special paints are for outside surfaces only. A safety data sheet is required on special paint and should be forwarded to the plant prior to quotation. CORRO-DUTY® paint applied to WPI motors does not include cast-iron components. See tables below.

Special Paint List Adders (when approved)

Frame Size	182 184	213 215	254 256	284 286	324 326	364 365	404 405	444 445	447
List Price	\$352	\$469	\$587	\$704	\$822	\$939	\$1,056	\$1,174	\$1,174

Frame Size	449/5000	5800	6812 (TE)	6800-8000	9600
List Price	\$1,878	\$3,756	\$5,634	\$5,634	\$5,634

30. PLATFORMS, LADDERS AND RAILINGS

Inherent to their design, vertical motors are more susceptible to sympathetic vibration due to mechanical resonance or reed critical frequency within the pumping system. Adding motor-mounted maintenance platforms, ladders and railings can excite this condition. Nidec Motor Corporation does not recommend or supply motor-mounted maintenance platforms.

Should maintenance platforms, ladders and railings be a customer requirement, we suggest using a free-standing design.



† All marks shown within this document are properties of their respective owners.

MODIFIABLE PRICING INSTRUCTIONS



31. POWER FACTOR

- CAUTION -- DO NOT over correct the power factor of products described in this catalog. Correcting full-load power factor beyond approximately 95% will potentially result in severe non-warranty damage to the motor and driven equipment.
- Seek assistance from the Inquiry Group to apply this product to multispeed motors.
- On single voltage motors with part winding (PWS), Double Delta or WYE Delta starting connections, Nidec Motor Corporation recommends the capacitor be connected to the motor side of contactors 1-2-3 in the motor starter.
- If this is unacceptable, you must supply two separate capacitors each with one half of the desired KVAR rating. One capacitor should be connected to the 1-2-3 motor leads, the second connected to 4-5-6 (or 7-8-9 as applicable).
- Do not apply this accessory to a variable frequency drive. Serious damage to the VFD will result if capacitors are used in between drive and motor. Consult your drive supplier.
- Seek assistance from the Inquiry Group if any questions exist.

Application of power factor correction capacitors to three-phase squirrel cage induction motors (SCIM) is beneficial because the power used by industrial and municipal facilities has two components:

1. Real power (KW), which produces work.
2. Reactive power (KVAR) needed to generate the rotating magnetic field required for the operation of electric motors. No useful work is performed by this component.

Reactive power is sometimes called wattless power because inductive electrical equipment, such as a motor, must take from the electrical distribution system more current than is necessary to do work involved. The ratio of working current to total current is called power factor. The function of power factor correction capacitors is to increase the power factor by supplying the wattless power when installed at or near inductive electrical equipment.

Here, the power feeder line must supply useful real power and reactive or magnetizing currents.

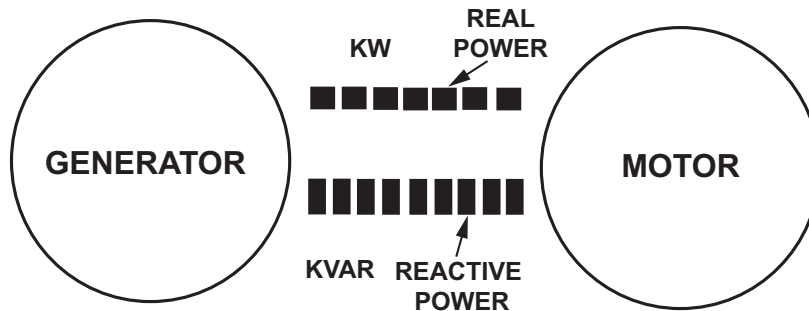

Illustration of an SCIM under partially loaded conditions without Power Factor Correction Capacitors (PFCC).



MODIFIABLE PRICING INSTRUCTIONS

POWER FACTOR

31. POWER FACTOR (continued)

Installing a PFCC near the same motor will supply the reactive or magnetizing current required to operate it. The total current required of the power feeder line is reduced to the value of the useful real current only.

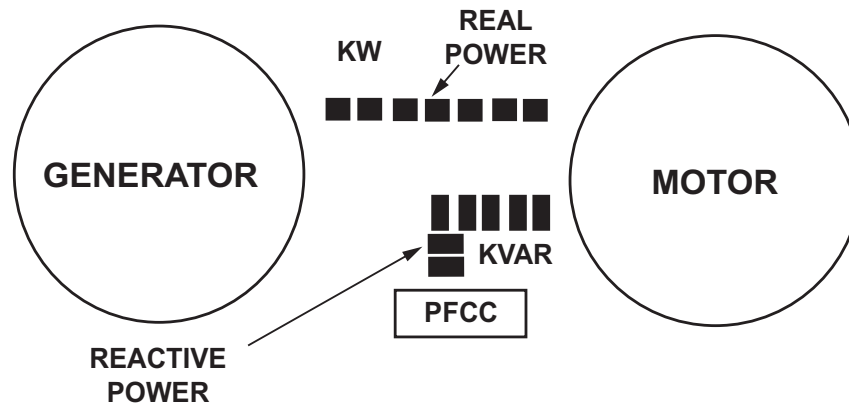

Power factor correction capacitors can lower electrical costs. In many areas, the cost of electricity includes a penalty charge for low power factor. Installation of power factor correction capacitors on the distribution system within the plant makes it unnecessary for the utility to supply the wattless or the non-working power required by the inductive electrical equipment connected to it. Savings in reduced generation, transmission, and distribution costs are passed on to the plant in the form of lower electrical bills.

Savings are also possible through the use of power factor correction capacitors in the form of increased KVA capacity of plant electrical distribution system. Power factor correction capacitors furnish the non-productive current requirements of the plant and make it possible to increase the plant connected load, as much as 15 to 20%, without a corresponding increase in the size of transformers, conductors and protective devices making up the distribution system servicing the load.

Listed in the engineering data section of this catalog is the maximum amount of KVAR allowed to be applied to the specific product described. This generally corrects the motor's full-load power factor of 95%. Should a customer require correction to a lower value, apply the following formula to obtain the required KVAR. KVAR is the unit for rating PFCC and is equal to 1000 volt-amperes of reactive power. This indicates how much reactive power the capacitor will provide.

To determine KVARs needed to improve the motor's existing full-load power factor to 92%:

$$\text{Actual Power} = \frac{\text{Volts} \times \text{Amps} \times \% \text{ P.F} \times 1.732}{1000}$$

Motor is 100 HP, 1200 RPM, 460 volts with 79.1% full-load power factor TEFC VHS premium efficient type TVS with 124 full load amps

$$\text{Actual Power} = \frac{460 \times 124 \times 0.791 \times 1.732}{1000}$$

$$\text{Actual Power} = 78.15 \text{ KW}$$



MODIFIABLE PRICING INSTRUCTIONS

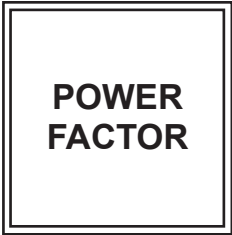

31. POWER FACTOR (continued)

- Obtain from table 32-1 the KW multiplier at the intersection of 79% original PF and 92% desired PF multiplier = 0.35. KVAR = 78.15 x 0.35 = 27.4
- Performance data indicates 33 KVAR is maximum, 27.4 is needed, correction to 92% is possible.

Table 31-1

ORIGINAL POWER FACTOR	KW MULTIPLIERS TO DETERMINE CAPACITOR KVAR REQUIRED															
	CORRECTED POWER FACTOR															
	0.80	0.81	0.82	0.83	0.84	0.85	0.86	0.87	0.88	0.89	0.90	0.91	0.92	0.93	0.94	0.95
0.60	0.583	0.609	0.635	0.661	0.687	0.713	0.740	0.766	0.793	0.821	0.849	0.877	0.907	0.938	0.970	1.044
0.61	0.549	0.575	0.601	0.627	0.653	0.679	0.706	0.732	0.759	0.787	0.815	0.843	0.873	0.904	0.936	0.970
0.62	0.516	0.542	0.568	0.594	0.620	0.646	0.673	0.699	0.726	0.754	0.782	0.810	0.840	0.871	0.903	0.937
0.63	0.483	0.509	0.535	0.561	0.587	0.613	0.640	0.666	0.693	0.721	0.749	0.777	0.807	0.838	0.870	0.904
0.64	0.451	0.477	0.503	0.529	0.555	0.581	0.608	0.634	0.661	0.689	0.717	0.745	0.775	0.806	0.838	0.872
0.65	0.419	0.445	0.471	0.497	0.523	0.549	0.576	0.602	0.629	0.657	0.685	0.713	0.743	0.774	0.806	0.840
0.66	0.388	0.414	0.440	0.466	0.492	0.518	0.545	0.571	0.598	0.626	0.654	0.682	0.712	0.743	0.775	0.809
0.67	0.358	0.384	0.410	0.436	0.462	0.488	0.515	0.541	0.568	0.596	0.624	0.652	0.682	0.713	0.745	0.779
0.68	0.328	0.354	0.380	0.406	0.432	0.458	0.485	0.511	0.538	0.566	0.594	0.622	0.652	0.683	0.715	0.749
0.69	0.299	0.325	0.351	0.377	0.403	0.429	0.456	0.482	0.509	0.537	0.565	0.593	0.623	0.654	0.686	0.720
0.70	0.270	0.296	0.322	0.348	0.374	0.400	0.427	0.453	0.480	0.508	0.536	0.564	0.594	0.625	0.657	0.691
0.71	0.242	0.268	0.294	0.320	0.346	0.372	0.399	0.425	0.452	0.480	0.508	0.536	0.566	0.597	0.629	0.663
0.72	0.214	0.240	0.266	0.292	0.318	0.344	0.371	0.397	0.424	0.452	0.480	0.508	0.538	0.569	0.601	0.635
0.73	0.186	0.212	0.238	0.264	0.290	0.316	0.343	0.369	0.396	0.424	0.452	0.480	0.510	0.541	0.573	0.607
0.74	0.159	0.185	0.211	0.237	0.263	0.289	0.316	0.342	0.369	0.397	0.425	0.453	0.483	0.514	0.546	0.580
0.75	0.132	0.158	0.184	0.210	0.236	0.262	0.289	0.315	0.342	0.370	0.398	0.426	0.456	0.487	0.519	0.553
0.76	0.105	0.131	0.157	0.183	0.209	0.235	0.262	0.288	0.315	0.343	0.371	0.399	0.429	0.460	0.492	0.526
0.77	0.079	0.105	0.131	0.157	0.183	0.209	0.236	0.262	0.289	0.317	0.345	0.373	0.403	0.434	0.466	0.500
0.78	0.052	0.078	0.104	0.130	0.156	0.182	0.209	0.235	0.262	0.290	0.318	0.346	0.376	0.407	0.439	0.473
0.79	0.026	0.052	0.078	0.104	0.130	0.156	0.183	0.209	0.236	0.264	0.292	0.320	0.350	0.381	0.413	0.447
0.80	0.000	0.026	0.052	0.078	0.104	0.130	0.157	0.183	0.210	0.238	0.266	0.294	0.324	0.355	0.387	0.421
0.81		0.000	0.026	0.052	0.078	0.104	0.131	0.157	0.184	0.212	0.240	0.268	0.298	0.329	0.361	0.395
0.82			0.000	0.026	0.052	0.078	0.105	0.131	0.158	0.186	0.214	0.242	0.272	0.303	0.335	0.369
0.83				0.000	0.026	0.052	0.079	0.105	0.132	0.160	0.188	0.216	0.246	0.277	0.309	0.343
0.84					0.000	0.026	0.053	0.079	0.106	0.134	0.162	0.190	0.220	0.251	0.283	0.317
0.85						0.000	0.027	0.053	0.080	0.108	0.136	0.164	0.194	0.225	0.257	0.291
0.86							0.000	0.026	0.053	0.081	0.109	0.139	0.167	0.198	0.230	0.264
0.87								0.000	0.027	0.055	0.083	0.111	0.141	0.172	0.204	0.238
0.88									0.000	0.028	0.056	0.084	0.114	0.145	0.177	0.211
0.89										0.000	0.028	0.056	0.086	0.117	0.149	0.183
0.90											0.000	0.028	0.058	0.089	0.121	0.155
0.91												0.000	0.030	0.061	0.093	0.127
0.92													0.000	0.031	0.063	0.097
0.93														0.000	0.032	0.066
0.94															0.000	0.034
0.95																0.000



† All marks shown within this document are properties of their respective owners.

MODIFIABLE PRICING INSTRUCTIONS

PRINTS
ROTOR

32. PRINTS AND DATA

When requested at time of order entry, Nidec Motor Corporation will supply at no charge a standard submittal package consisting of 5 sets of the following: motor description, features, dimension print, nameplate data and performance data. For non-standard products, data, those requiring engineering content, refer to the following chart for applicable charges (per rating). Note that pricing is net.

CODE	DESCRIPTION	NET/EACH
B/N/B	USEM AND BEARING MANUFACTURER'S PART NUMBERS	N/C
	BEARING LIFE CIRCULATION	\$150
CP	CERTIFIED DIMENSION PRINT (USEM STANDARD 8-1/2 X 11)	N/C
D/S	CUSTOMER DATA SHEET FILLED OUT BY NIDEC	\$60
• I/M	GENERAL INSTALLATION, OPERATION & MAINTENANCE MANUAL . QTY-5 PER ORDER ADDITIONAL COPIES (MINIMUM QTY. 5)	N/C \$5
L/N	SOUND POWER IN WATTS	\$60
L/P	SOUND PRESSURE IN db AT FIVE FEET	\$30
N/P	NAMEPLATE DATA	N/C
N/Y	CITY OF (NEW YORK) DATA SHEET	\$60
P/AA	ACCELERATION TIME VS. AMPS CURVE (REQUIRES CUSTOMER'S LOAD WK ² AND LOAD SPEED TORQUE CURVE)	\$170
P/C	PERFORMANCE CURVE (SLIP OR RPM, AMPS, EFF, PF, KW VS. HP)	\$170
P/D	PERFORMANCE DATA (SAME AS ABOVE EXCEPT IN DATA FORM)	N/C
P/E	EQUIVALENT CIRCUIT PARAMETERS	\$60
P/L	PARTS LIST (EXPLODED VIEW) FROM PRICE BOOK SECTION 700	N/C
P/N	STANDARD NOISE DATA VS. CENTER BAND	\$60
P/ST	SPEED VS. TORQUE & AMPS CURVE	\$60
P/TA	SAFE STALL TIME CURVE (TIME VS. AMPS)	\$170
RCF	REED CRITICAL FREQUENCY DATA	N/C
S/P	RECOMMENDED SPARE PARTS (BEARINGS, SEALS) SEE P/L	N/C
S/S	SHAFT STIFFNESS/MODULUS OF ELASTICITY	\$170
SP	SHAFT PRINT	\$60
CRS	LATERAL ANALYSIS, ROTOR DETAIL, AND SHAFT PRINT	\$330
MED	MASS ELASTIC DATA	\$170
W/D	EXTERNAL WIRING (CONNECTION) DIAGRAM (INCLUDES ACCESSORY CONNECTION DIAGRAMS WHEN APPLICABLE)	N/C
R/I	ROTOR INERTIA	N/C
RCS	ROTOR DYNAMIC ANALYSIS (ROTOR CRITICAL SPEED)	\$2500

NOTE: Requests for data after order has been entered, for additional data, additional copies or resubmittal after changes will carry a basic charge of \$50 net per rating in addition to the charges noted above.

Submittals requiring express mailing (at customer request) will be sent prepaid and the cost of the mailing added to the order price.

- When requested, Nidec Motor Corporation will fill in data on customer data sheets. Original sheets must be supplied by customer at time of order entry. Data sheets must be originals or first-generation copies on standard 8-1/2 x 11 paper, completely legible and have standard font spacing. Data sheets that do not meet Nidec Motor Corporation criteria will not be completed. For data not listed above, refer to the Inquiry Group for availability.
- Above represents software requirements of most heavy-industrial customers. In some cases, this is but a small portion of the data requirements of highly specialized and controlled environments. Nidec Motor Corporation recognizes our customers with these concerns and can provide software that supports their needs. Pricing varies by requirement; refer to the Inquiry Group for special software.
- Request for detailed information for motors that are 5 years or older will be charged \$300 net per motor.
- CE Mark — not required for motors rated above 1000 volts. Contact the Inquiry Group regarding the CE Mark for motors rated at or below 1000 volts.



† All marks shown within this document are properties of their respective owners.

MODIFIABLE PRICING INSTRUCTIONS



32. PRINTS AND DATA (continued)

- UL Certificate -- “Motor Certificate” is available for UL-listed motors only. This certificate from Underwriters Laboratories states that a specific product (mode / I.D.) conforms with specific UL standards. Add \$1000 net each rating.

33. REED CRITICAL

Vertical pump systems have natural frequencies which are a function of system stiffness, mass and mounting. Natural frequency is the frequency at which a structure vibrates with the presence of a minimal forcing function. Reed Critical Frequency (RCF) is the first bending mode lateral natural frequency of a vertical structure. When a natural frequency is excited by a driving force, such as a small residual unbalance, vibration problems can result.

To avoid vibration problems, pump manufacturers determine the pumping system RCF to avoid operation on or near the RCF. This is particularly important when a pump/motor system is driven at variable speed with inverter power. Pump manufacturers can make their discharge heads either stiff or flexible or purchase a motor with a larger or smaller mounting flange to change the system RCF.

Motor RCF data is required in order to assist the pump manufacturer in determining the system RCF. Nidec Motor Corporation will provide typical Reed Critical Frequency data at no extra charge when requested.

Typical motor RCF data may be verified by performing a RCF test after the motor has been manufactured. See Testing, Item 48, for the applicable witnessed or un-witnessed RCF test charge.

34. ROTOR, STANDARD AND OPTIONAL CONSTRUCTION

- Standard rotor construction of NEMA[®]† frame products in the 182 through 447 frame series is die-cast aluminum. Optional rotor construction is not available.
- Standard rotor construction of 449, 5000 and 5800 frame TITAN[®] products is typically die-cast aluminum. 720 RPM and slower is typically fabricated aluminum. Optional rotor construction is available as shown below.
- Standard rotor construction of the 6800, 8000 and 9600 frame products is fabricated aluminum. Optional rotor construction is shown below.
- Nidec Motor Corporation reserves the right to deviate from the above as good engineering practice dictates.
- Optional rotor designs will change published performance characteristics.
- Fabricated copper bar rotor construction is available in the 449 through 9600 frame series. Centrifugally cast end rings are fully brazed to each rotor bar. Rotor bars are swagged, preventing in-slot movement and tight bar construction. Heavy finger plates tightly hold the rotor cove together, controlling internal stress and maintaining dimension stability under all loads.

LIST PRICE ADDITIONS FOR OPTIONAL CONSTRUCTION					
ROTOR	449/5000	5800	6812 (TE)	6800-8000	9600
2 pole copper	\$38,732	\$42,254	N/A	N/A	N/A
4 pole and slower copper	\$32,277	\$35,211	\$37,559	\$39,906	\$42,254
Fabricated aluminum	\$2,750	\$4,500	STD	STD	STD



MODIFIABLE PRICING INSTRUCTIONS

SCREENS SEALS

35. SCREENS

Screens are standard on all WPI "P" base motors. Stainless-steel screens with 1/4 inch mesh are available for list adder below.

FRAME SIZE	182 184	213 215	254 256	284 286	324 326	364 365	404 405	444 447	449 5000	5800	6800	8000	9600
STAINLESS STEEL SCREEN	\$469	\$469	\$469	\$528	\$763	\$1,115	\$1,115	\$1,761	\$1,761	\$1,761	\$2,200	\$2,200	\$2,495

36. SEALS

Shaft slingers or seals may be installed on the shaft end of vertical motors to prevent the ingress of dirt and liquid. Contact the Inquiry Group for availability on vertical HOLLOSHAFT® motors.

Shaft Slinger

Frame:	182 184	213 215	254 256	284 286	324 326	364 365	404 405	444 447	449	5000	5800	6812 (TE)	6800- 8000	9600
Adder:	\$141	\$141	\$200	\$200	\$270	\$270	\$340	\$376	\$469	\$469	\$469	\$469	\$469	\$469

* Shaft Slinger: Installed on the shaft at the bracket face to prevent the ingress of dirt and liquid. Usually made of rubber.

Lip Seal - TEFC Only

Frame:	182 184	213 215	254 256	284 286	324 326	364 365	404 405	444 445	447	449	5000	5800	6812 (TE)	6800- 8000	9600
Adder:	\$141	\$200	\$200	\$200	\$270	\$270	\$340	\$340	\$376	\$469	N/A	N/A	N/A	N/A	N/A

* Lip Seals: These seals provide a rubber shaft seal to exclude contaminants such as oil, water and dust from entering the bearing cavity.

INPRO/SEAL^{®†} - TEFC 320 - 6812 & 180 - 320 with Corro-Duty[®]

WPI/WPII 320 Frame and Large

Frame:	182 184	213 215	254 256	284 286	324 326	364 365	404 405	444 445	447	449	5000	5800	6812 (TE)	6800- 8000	9600
Adder:	\$352	\$352	\$587	\$822	\$822	\$1,056	\$1,291	\$1,291	\$1,549	\$1,937	\$3,815	\$3,815	\$3,815	\$3,815	\$3,815

* INPRO/SEAL^{®†}: This is a permanent, metallic, non-contact, non-wearing, radial-axial labyrinth pattern isolator. This design permanently retains the lubricant in the bearing housing and prevents entry of foreign material into the bearing environment.

INPRO/SEAL^{®†} Motor Grounding Seal (MGS^{®†}) - TEFC 182-6812

WPI/WPII 5000 Frame and Larger

Frame:	182 184	213 215	254 256	284 286	324 326	364 365	404 405	444 445	447	449	5000	5800	6812 (TE)	6800- 8000	9600
Adder:	\$1,056	\$1,056	\$1,761	\$2,466	\$2,466	\$3,168	\$3,873	\$3,873	\$4,647	\$5,811	\$11,445	\$11,445	\$11,445	\$11,445	\$11,445

* INPRO/SEAL^{®†} MGS^{®†}: This is a permanent, metallic, non-contact, non-wearing, radial-axial labyrinth isolator that also includes a shaft grounding device. The seal design permanently retains the lubricant in the bearing housing, prevents entry of foreign material. The grounding device inhibits damage to bearings by diverting stray shaft currents to ground.



† All marks shown within this document are properties of their respective owners.

MODIFIABLE PRICING INSTRUCTIONS



37. SERVICE FACTOR (OVERLOAD)

- As indicated on respective pricebook pages, many products described in this catalog include 1.15 S.F.
- Certain options (i.e., 50 Hz) can derate standard offering to 1.0 S.F. Use this adder to restore the 1.15 S.F.
- For TEFC motors (not Hazardous Location) with 1.15 S.F. refer to heavy-duty, CORRO-DUTY® and severe-duty product descriptions listed as item 13 on page M-26.
- For Hazardous Location products with 1.15 S.F., add as shown below.
- This option may influence frame size and performance characteristics. Published or guaranteed data will change when product is operated over nameplate HP.
- Contact the Inquiry Group for service factor requirements greater than 1.15 S.F.
- For slow-speed, large-frame products with 1.0 S.F. as standard, add as shown below for 1.15 S.F.
 - Premium Efficiency TEFC motors include 1.15 S.F. at no charge.

LIST PRICE ADDITIONS FOR 1.15 S.F. OPTION

FRAME SIZE	182 184	213 215	254 256	284 286	324 326	364 365	404 405	444 447	449
LIST PRICE	\$352	\$469	\$587	\$728	\$939	\$1,878	\$2,559	\$3,150	\$4,432

FRAME SIZE	5000	5800	6812 (TE)	6800-8000	9600
LIST PRICE	5%	5%	6%	6%	6%

Motors will be Class B temperature rise at nameplate HP, Class F temperature rise at 1.15 S.F. For temperature rise options, refer to item 46 on page M-62 of this section. Frame and performance characteristics may change.

38. SHAFT EXTENSIONS

Vertical Solid Shaft Only, Special Shaft List Price Additions.

- Basic adder — When a non-standard shaft extension is required, this addition must be made. This addition includes standard steel material, up to 10 inches longer than standard, with one standard size runner keyway and ring keyway.
- Special material addition — If non-standard material is required, this addition must be made in conjunction with the above addition. See table. Our standard high tensile steel shaft material is 4140.
- Special feature addition — The above additions include one standard size runner keyway and ring keyway in each extension. If other special shaft features (as listed below) are required, apply addition from table for each feature required. For example: A shaft with one step, a drilled and tapped hole in the end, and a Woodruff keyway, requires three additions.



MODIFIABLE PRICING INSTRUCTIONS



38. SHAFT EXTENSIONS (continued)

Special Features Available:

- Keyway -- sled-runner type, round end, or Woodruff
- Drilled Hole -- diametrically through shaft or in end
- Steps -- each step or reduced diameter from standard straight shaft (usually needed with thread modification)
- Threads -- right hand thread size appropriate to the shaft diameter (usually needs addition for step for thread)
- Hole drilled and tapped in end of shaft
- Squared -- milled flats on one step, four sides
- Tapered -- 1 - 1/4" or 1-1/2" per foot taper with threads, nut and lock washer

SPECIAL SHAFT ADDITIONS:

DESCRIPTION	QUANTITY OF MOTORS	FRAME SIZE - LIST PRICE										
		182 184	213 215	254 256	284 286	324 326	364 365	404 405	444 445 447	449 5000 5800	6800- 8000	9600
BASIC ADDITIONS	1-4 5 OR MORE	\$904 \$108	\$1,085 \$155	\$1,164 \$178	\$1,317 \$254	\$1,427 \$317	\$1,681 \$387	\$1,969 \$455	\$2,265 \$577	\$3094 \$777	\$3,873 \$974	\$4,366 \$1,092
SPECIAL MATERIAL ADDITIONS: STAINLESS STEEL* (303, 304, 416)	ANY	\$225	\$474	\$711	\$1,066	\$1,941	\$2,484	\$3,613	\$3,901	\$5,124	RO	RO
HIGH TENSILE STEEL (4140 or 17-4H)	ANY	\$49	\$178	\$230	\$366	\$667	\$899	\$1,244	\$1,282	\$1,678	\$5,869	\$6,221
SPECIAL FEATURES ADDITION (EACH)	ANY	\$31	\$35	\$42	\$52	\$68	\$75	\$85	\$99	\$131	RO	RO

*Refer to the Inquiry Group for non-magnetic stainless-steel shafts on 2 pole motors (303 or 304 stainless).
RO -- Refer to the Inquiry Group

Shaft Ground Rings

Inverters generate common mode voltage which may induce motor bearing current. A shaft ground ring helps prevent bearing damage by short-circuiting the current to ground. Inverter duty motors include a shaft ground ring on motors in the 320 frame and larger. The following list price adders can be used to add a shaft grounding ring to inverter duty motors smaller than the 320 frame or to add them to non-inverter duty motors. Nidec Motor Corporation offers shaft ground rings by AEGIS[†] and INPRO/SEAL[†] and shaft ground brushes by Helwig Carbon[†]. For Helwig Carbon shaft ground brushes, please contact office for price & availability.

Aegis[†] Shaft Ground Ring (SGR[†])

Frame:	182 184	213 215	254 256	284 286	324 326	364 365	404 405	444 447	449	5000	5800	6812 (TE)	6800- 8000	9600
Adder:	\$350	\$350	\$510	\$550	\$710	\$710	\$1,115	\$1,291	\$1,937	\$3,815	\$3,815	\$3,815	\$3,815	\$3,815

AEGIS[†] SGR : Inhibits damage to bearings by diverting stray shaft currents to ground.



† All marks shown within this document are properties of their respective owners.

MODIFIABLE PRICING INSTRUCTIONS



38. SHAFT EXTENSIONS (continued)

INPRO/SEAL^{®†} Shaft Ground Ring (CDR^{®†})

Frame:	182 184	213 215	254 256	284 286	324 326	364 365	404 405	444 447	449	5000	5800	6812 (TE)	6800 8000	9600
Adder:	\$350	\$350	\$510	\$550	\$710	\$710	\$1,115	\$1,291	\$1,937	\$3,815	\$3,815	\$3,815	\$3,815	\$3,815

INPRO CDR^{®†} : Inhibits damage to bearings by diverting stray shaft currents to ground.

39. SNOWMASTER[™]

Nidec Motor Corporation offers a WPI vertical motor specially designed to withstand the rigors of snowmaking applications. The SNOWMASTER[™] motor utilizes proven winding treatments, a Microflow Oil system that provides proper lubrication without oil churning and optimum thrust-bearing protection via an oil bath arrangement on 400 frame & larger. In addition, inverter duty (includes normally closed thermostats 1/phase, shaft ground ring and an insulated upper thrust bearing), Class H insulation, space heaters, a 1.15 service factor on sinewave power, refined balance and corrosion-resistant paint make this product the answer to your electric motor requirements for snowmaking pumps. See pages P-63 and P-64 for pre-priced ratings. For ratings not listed, price as a premium efficiency motor and add the following list adder and note "SNOWMASTER" on the order.

FRAME SIZE	405	444, 445	5000
LIST ADDER	12.5%	12.5%	10%

40. SPACE HEATERS

We recommend low watt density space heaters be used to prevent condensation within the motor during idle periods. Space heaters are silicone rubber "strip-type" wrapped around and bonded to the end turns. Unlike cartridge-type heaters, these provide even heating with 5^o C to 10^o C temperature rise within the motor and exceptionally long life. Nidec Motor Corporation no longer offers cartridge-type heaters due to concern about life expectancy. Heater leads are brought out to the main conduit box on ratings, 600 volts and below. A single accessory box is included at no charge for motors rated above 600 volts.

- Standard space heaters are single phase, 50 or 60Hz and available in 115, 230, 460 or 575 volt ratings. Please specify detail at order entry.
- For hazardous location or Division 2 applications, double adder.
- For thermostatically controlled space heater -- **available on 440 through 9600 frames only** -- add \$1,444 list to space heater addition shown. A calibrated (preset) thermostatic control accessory is mounted in motor conduit box. Not available on hazardous location motors.
- For pilot light located on space heater conduit box to indicate space heater operation -- **440 through 9600 frame only** -- add \$3,331 list. Not available on hazardous location motors.
- For half voltage space heater (rated 240 volts operated on 120 volts), double list price adder shown below -- **available 324 and larger frames** -- nonhazardous location only.
- For space heater installed in a size 4, 5, or 6 main conduit box add \$2,864 list. Includes conduit off main box with 3/4" A-A hub.
- Heaters are included at no charge (when specified at order entry) on all WPII enclosures.



MODIFIABLE PRICING INSTRUCTIONS

**SPACE
HEATERS
SPEED
SWITCH**

40. SPACE HEATERS (continued)

LIST PRICE ADDITIONS FOR STANDARD SILICONE RUBBER, STRIP TYPE SPACE HEATERS

FRAME SIZE	182 184	213 215	254 256	284 286	324 326	364 365	404 405	444 445	447
LIST ADDER	\$300	\$300	\$300	\$300	\$385	\$385	\$385	\$385	\$385
HAZARDOUS LOCATION	\$601	\$601	\$601	\$601	\$770	\$770	\$770	\$770	\$770

FRAME SIZE	449/5000	5800	6800	8000	9600
LIST ADDER	\$1,657	\$1,819	\$2,789	\$2,789	\$2,789
HAZARDOUS LOCATION	\$3,317	\$3,638	\$5,575	\$5,575	\$5,575

Space heater watts will be:

FRAME	NOMINAL WATTAGE	
	WP-1 OR WP-2	TEFC
180	36	36
210	36	36
250	48	48
280	72	72
320	96	96
360	96	144
400	144	192
440	192	192
449/5000	288	288
5800	384	384
6800	480	-
8000	700	-
9600	900	-

41. SPEED SENSING SWITCH (ZERO SPEED SWITCH)

- Same as anti-plugging or zero speed switch
- Available only on vertical solid shaft products
- Available on 449 through 9600 frame

Nidec Motor Corporation offers a digital speed switch for precision rotation monitoring over a full range of speeds from 0.5 - 5000 RPM. Rated single phase, 115 volts with relay contact rating of 5A, SPDT includes terminal strip connections, weatherproof conduit head.

LIST PRICE ADDITION - SPEED SWITCH	
449 - 9600 (WPI, WPII, TEFC)	\$9,366
Option - DPDT Relay	\$660
Option - Hazardous location connection head	\$915

SPDT - Single pole double throw; DPDT - Double pole double throw



† All marks shown within this document are properties of their respective owners.

MODIFIABLE PRICING INSTRUCTIONS



42. STAINLESS-STEEL HARDWARE

Stainless-steel hardware is furnished at the prices below, including condensation drain and all machine screws required for endshields, fan cover, bearing caps, conduit box, canopy can, and fan. Standard-plated hardware is changed to 316 stainless steel. Stainless Steel hardware is not available on hazardous location motors. Reference MEC-43 on order.

FRAME SIZE	182	213	254	284	324	364	404	444	449
	184	215	256	286	326	365	405	447	
LIST PRICE	\$282	\$282	\$282	\$282	\$528	\$528	\$528	\$528	\$547

FRAME SIZE	5000	5800	6812 (TE)	6800-8000	9600
LIST PRICE	\$547	\$547	\$573	\$735	\$735

43. STARTING

- Products described in this catalog are assumed to be used with the full voltage across the line starting method.
- Some stock products feature part winding start (PWS) or Wye-Delta starting as a standard feature on 460 volts.
- Stock products rated 230/460 volts are suitable for PWS on 230 volts.
- Products supplied with either PWS or Wye-Delta winding configurations can also be used when full voltage across The line starting is required.
- Some stock products may be capable of being reconnected (by a motor repair facility) for a different starting method.
Contact the Inquiry Group with requirements.
- Nameplate (HP) ratings assume product is applied to a power distribution system with balanced line voltage. Distribution systems using an asymmetrical transformer bank (typically open Wye, open Delta connection) almost always produce unbalanced line voltage conditions leading to premature motor failure.
- Standard products described in this catalog may be capable of alternative starting methods, provided certain basic requirements are met:

A) Motor must be capable of accelerating the load under the specified starting method without exceeding the allowable temperature rise of the rotor or stator.

B) Motor must produce adequate torque at all points along the driven equipment load curve so as not to stall at an intermediate load point.

Products described in this catalog can be connected directly across the line without damage to the motor. However, the typical motor draws 6 to 7 times its full load current during starting. These are situations where this starting or in-rush current can cause excessive voltage disturbance on the power supply system -- potentially causing operational problems with other equipment. Reducing voltage to the motor during starting is a common method of controlling in-rush current. Reducing voltage to the motor during starting also reduces the starting torque and breakdown torque, which increases the time it takes the motor to accelerate.



MODIFIABLE PRICING INSTRUCTIONS



43. STARTING (continued)

TYPICAL SPEED-TORQUE CURVE

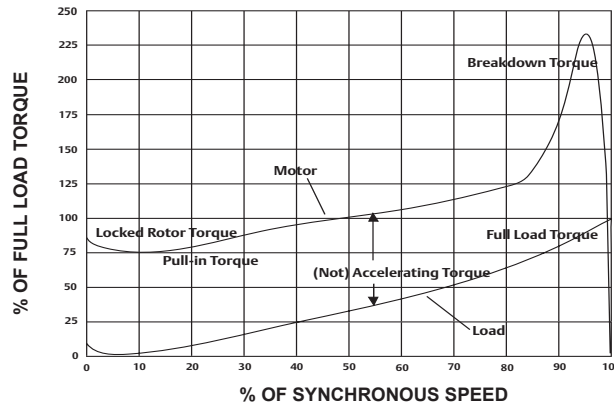

Should the starting torque be reduced at some point along the speed torque curve to where there is no longer a net accelerating torque value, the motor will stall and can be damaged if not taken offline within its safe stall time window. Comparing the pump speed -- torque curve with the motor's capabilities under reduced voltage starting conditions -- is recommended, particularly when 50% of nameplate voltage is used to start the motor (50% tap on auto transformer). Motors started by autotransformer or solid-state soft-starting methods require customer to provide speed torque curve of driven equipment, voltage tap on transformer and WR^2 of load.

Typical Comparison of Common Starting Methods (%)					
STARTING METHOD	MOTOR			LINE	NOTES
	TERMINAL VOLTAGE	STARTING TORQUE	STARTING CURRENT	STARTING CURRENT	
Full Voltage	100	100	100	100	Standard Motor
PWS (High Speed)	100	50	70	70	Special Winding [†]
PWS 514 RPM + Below	100	50	50	50	Special Winding [†]
Wye-Delta	100	33	37	33	Special Winding [†]
AUTOTRANSFORMER					*Includes Transformer magnetizing current
80% TAP	80	64	80	67*	
65% TAP	65	42	65	45*	
50% TAP	50	25	50	28*	
PRIMARY RESISTOR AND PRIMARY REACTOR ARE SIMILAR TO AUTOTRANSFORMER METHOD					

NOTE ^(†) - STANDARD ON SOME STOCK MOTORS



† All marks shown within this document are properties of their respective owners.

MODIFIABLE PRICING INSTRUCTIONS



43. STARTING (continued)

A. PART WINDING START (PWS)

- Maximum timed transition from part winding to full winding should never exceed 2 to 3 seconds
- Do not attempt to accelerate load on part winding beyond 2 to 3 seconds (see note below)
- PWS motors can also be connected to the full voltage, across the line method
- Use this adder (PWS) when double delta connection is specified

Part winding start is only used to establish normal starting current in two steps rather than one. This allows the utilities automatic voltage regulators on the power distribution system time to adjust the voltage in order to compensate for the pull down due to the high initial current draw. Double Delta PWS uses all of the windings in series, then switches to two parallel delta for run mode. Starting connection produces insignificant starting torque.

SPECIAL NOTE:

When a motor is in the part winding start mode, the heating rate in the energized portion of the winding is 2.25 times the rate it is on full winding (full voltage). Two seconds on PWS is equivalent to 4.5 seconds on full winding, and the shaft may be barely turning if at all.

List Price Adders: Part Winding or Double Delta Start

FRAME SIZE	182	213	254	284	324	364	404	444	447
	184	215	256	286	326	365	405	445	449
PART WINDING	NA	NA	\$99	\$131	\$202	\$291	\$451	NC	NC

FRAME SIZE	5000	5800	6812 (TE)	6800-8000	9600
PART WINDING	NC	NC	NC	NC	NC

B. WYE DELTA (STAR-DELTA) STARTING

- Wye-Delta start may also be used with the full voltage or DOL (Direct On-Line) methods
- When ordered with the 50 Hz option, there is no charge for this feature

The Wye-Delta method, also known as Star-Delta, connects the motor winding to an external Wye configuration during starting, then quickly reconnects the winding to a Delta configuration for the run mode. This transition occurs internal to the starter. Open transition starters disconnect the motor momentarily; closed transition starters use resistors during this transition (Wye to Delta).

List Price Adders: Wye-Delta Start

FRAME SIZE	182	213	254	284	324	364	404	444	447
	184	215	256	286	326	365	405	445	449
WYE-DELTA	\$99	\$99	\$99	\$131	\$202	\$291	\$451	NC	NC

FRAME SIZE	5000	5800	6812 (TE)	6800-8000	9600
WYE-DELTA	NC	NC	NC	NC	NC



† All marks shown within this document are properties of their respective owners.

MODIFIABLE PRICING INSTRUCTIONS

STARTING

43. STARTING (continued)

C. ALLOWABLE NUMBER OF STARTS PER HOUR

- NEMA MG1-12.54 states a motor shall be capable of 2 cold starts (from ambient) or 1 hot start (rated load operating temperature).
- Each start is one factor in the life expectancy and reliability of a motor. As a result, some reduction in life expectancy must be accepted when a motor is applied at the upper range of the starting duty determined below.
- Qualification — Assumption for use of this table is that the motor in question is:
 - A. Started full voltage across the line
 - B. Used on sine wave power at rated frequency
 - C. Driven equipment BHP is less than, or equal to motor nameplate HP exclusive of service factor
 - D. Supply voltage is balanced and at nameplate value
 - E. Applied to a variable torque load (pump)
 - F. Consult the Inquiry Group if questions exist

Example 1:

50 HP, 4 POLE, 1800 RPM, Design B motor direct connected to a pump with a WK^2 of 20 $lb \cdot ft^2$.

From the table on the following page we find:

$$A=6.8$$

$$B/Load\ Wk^2 = 232/20 = 11.6$$

$$C = \text{Minimum off time} = 72 \text{ seconds}$$

The value of $B/Load\ Wk^2$ exceeds the maximum number of starts per hour ($A=6.8$). Therefore, the motor must be limited to the maximum of 6.8 starts per hour with a minimum off time between starts of 72 seconds.

Example 2:

25 HP, 2 Pole, 3600 RPM, Design B motor direct connected to pump with a Wk^2 of 7.34 $lb \cdot ft^2$.

From the table on the following page we find:

$$A=4.4$$

$$B/Load\ Wk^2 = 26/7.34 = 3.5$$

$$C = \text{Minimum off time} = 115 \text{ seconds}$$

The value of $B/Load\ WK^2$ is less than the maximum number of starts per hour, and therefore, the motor must be limited to 3.5 starts per hour with a minimum off time (at rest) between starts of 115 seconds.

A list of NEMA standard WR^2 values follows this accessory section.



MODIFIABLE PRICING INSTRUCTIONS



43. STARTING (continued)

C. ALLOWABLE NUMBER OF STARTS PER HOUR

Allowable Number of Starts and Minimum Time Between Starts for Design A and Design B Motors

HP	2 Pole			4 Pole			6 Pole		
	A	B	C	A	B	C	A	B	C
1	15	1.2	75	30	5.8	38	34	15	33
1.5	12.9	1.8	76	25.7	8.6	38	29.1	23	34
2	11.5	2.4	77	23	11	39	26.1	30	35
3	9.9	3.5	80	19.8	17	40	22.4	44	36
5	8.1	5.7	83	16.3	27	42	18.4	71	37
7.5	7.0	8.3	88	13.9	39	44	15.8	104	39
10	6.2	11	92	12.5	51	46	14.2	137	41
15	5.4	16	100	10.7	75	50	12.1	200	44
20	4.8	21	110	9.6	99	55	10.9	262	48
25	4.4	26	115	8.8	122	58	10.0	324	51
30	4.1	31	20	8.2	144	60	9.3	384	53
40	3.7	40	130	7.4	189	65	8.4	503	57
50	3.4	49	145	6.8	232	72	7.7	620	64
60	3.2	58	170	6.3	275	85	7.2	735	75
75	2.9	71	180	5.8	338	90	6.6	904	79
100	2.6	92	220	5.2	441	110	5.9	1181	97
125	2.4	113	275	4.8	542	140	5.4	1452	120
150	2.2	133	320	4.5	640	360	5.1	1719	140
200	2.0	172	600	4.0	831	300	4.5	2238	265
250	1.8	200	1000	3.7	1017	500	4.2	2744	440

How to use this table:

- A = Maximum number of starts per hour.
- B = Maximum product of starts per hour times load WK²
- C = Minimum rest or off time between starts in seconds.

The allowable starts per hour is the lesser of (1) A or (2) B DIVIDED BY THE LOAD WK².

$$\text{Starts per hour} \leq A \leq \frac{B}{\text{Load WK}^2}$$



MODIFIABLE PRICING INSTRUCTIONS

**STARTING
STEADY
BUSHING**

43. STARTING (continued)

D. STARTING CURRENT

LOWER THAN STANDARD -- 210 through 440 frames -- where vertical motors are required to have starting current reduced from standard (NEMA Code G) to NEMA code F, make price additions. Note that this rule is applicable only to motors 15HP and larger. Starting torque and breakdown torque may be reduced to less than NEMA Design B limits. Efficiency will also be negatively effected. Other requirements must be referred to the Inquiry Group. Include WK² of driven equipment load to see if practical to manufacture.

FRAME SIZE							
182	213	254	284	324	364	404	444
184	215	256	286	326	365	405	447
N/A	\$167	\$167	\$249	\$357	\$808	\$1,232	\$2,068

449 - 9600 frames -- Quote pending Inquiry Group approval. Adder as shown below.

Starting -- Standard starting current for Nidec Motor Corporation is 650-700%. If lower than standard is required, a price addition from the following table should be made.

Lowering of starting current results in lower starting and breakdown torque. A check of the application starting load requirements and possible voltage drop to assure satisfactory operation should be made prior to quoting.

STARTING CURRENT PERCENT	PRICE ADDITION
600-650%	7.5%
550-599%	10%
450-549%	15%

E. LOW VOLTAGE STARTING

Standard motors are capable of accelerating WK² loads per the published table as long as the motor terminal voltage does not drop below 80% for NEMA or 90% for TITAN[®] of the nominal motor voltage. For starting at lower than stated guidelines, make the following percentage additions:

STARTING CURRENT PERCENT	PRICE ADDITION
80-70%	7.5%
69-65%	12%

If the load inertia is 1/2 of the NEMA normal and load torque during acceleration does not exceed 60% of the motor rated torque, no price addition is required down to 75% voltage. Engineering verification of the motor capability is required prior to quotation. If the load inertia is greater than NEMA, both the inertia adder and the low voltage adder must be made.

NOTE: Motors designed for low-voltage starting may have higher than the standard in-rush current at full voltage.

44. STEADY BUSHING

In high-thrust pump applications, vertical HOLLOSHAFT[®] motors are sometimes requested with steady bushings. These are motor mounted near the P-base and the same size as the coupling bore, and center the pump head shaft to within .002 inches TIR inside the motor shaft. When a motor is connected to the pump, the motor shaft, pump shaft and steady bushing all rotate together and have the mechanical stability of a vertical solid shaft motor.



MODIFIABLE PRICING INSTRUCTIONS



44. STEADY BUSHING (continued)

As a general statement, all 2-pole motors and pumps with mechanical seals in their discharge head require steady bushings. Another common use is when long bearing spans exist between the stuffing box bearing and the motor coupling due to tall fabricated discharge heads or high ring bases. Here, steady bushings are used to minimize potential shaft critical speed (resonance) problems.

Steady bushings are used with either bolted couplings or motors equipped with a nonreverse ratchet (NRR). They are not recommended for use on motors with a self-release coupling (SRC) as their tight tolerance may inhibit lateral pump shaft movement should the pump shaft unscrew.

Steady bushings are typically made of SAE 660 bearing bronze (or equivalent) and are available as kits for all motors with grease-lubricated lower bearings. These replace the v-groove rubber water slinger on the bottom end of the motor shaft. They are installed on the pump headshaft below the motor before securing it to the motor shaft with setscrews. Steady bushing kits for field installation are available from 182TP through 5000P frame on WPI motors and through 405TP frame for TEFC motors. **Production motors have kit attached to shipping skid.*

Steady bushing **CANNOT BE FIELD INSTALLED ON 5008 FRAME HAZARDOUS LOCATION TYPE EU OR ON ANY 6800 FRAME MOTORS WITH OIL BATH LOWER BEARINGS**. The motor shaft does not extend beyond the lower bracket as it does in the grease lube arrangement. The oil retaining tube, which is pressed into the lower P-base, actually fits up into the lower quill of the HOLLOSHAFT® bore. The steady bushing is pressed into the HOLLOSHAFT® bore and bottoms out about 5 inches from the end of the shaft. The last machining operation on the motor shaft is to finish bore the steady bushing for concentricity and tolerance.

When reviewing specifications, look in the equipment section (usually section 11000) to determine if the pump OEM is required to provide a mechanical seal in the discharge head instead of packing. If so, include a steady bushing in your quote and point it out to your customer. This is especially important on motors with oil bath lower guide bearings. In order to retrofit these, the motor must be completely disassembled and much machining performed. It would also be prudent to quote steady bushings as an option on NEMA[†] and TITAN[®] motors driven by inverters. This feature may be required to avoid pump shaft resonance problems, and this will serve as a reminder to check shaft critical speeds.

LIST PRICE ADDITION FOR STEADY BUSHINGS	
180-280 Frame	\$202
320-447 Frame	\$300
449-6812 (TE) Frame	\$523
6800-8000-9600 Frame	\$2,202



MODIFIABLE PRICING INSTRUCTIONS



44. STEADY BUSHING (continued)

STEADY BUSHING PART NUMBERS

FRAME	TYPE	KIT PART NUMBER	BORE SIZE
182, 184, 213 215, TP	AU, TU, LU	365649	3/4"
		978141	7/8"
		365650	1"
254, 256, 284, 286 UP, TPA, TPH, UPH, TP	AU, TU	365651	3/4"
		978142	7/8"
		365657	1"
		978143	1-1/16"
		365659	1-3/16"
		365662	1-1/4"
284, 286 TP, TPA, TPH	LU	978144	7/8"
		365663	1"
		365664	1-3/16"
		365665	1-1/4"
		978145	1-5/16"
		978146	1-1/2"
324, 326, 364, 365 TP, TPH	RU	978147	1"
		365666	1-3/16"
		365667	1-1/4"
		978148	1-5/16"
		365668	1-7/16"
		365669	1-1/2"
364, 365 TP, TPH	TU, LU	978149	1"
		365670	1-3/16"
		365671	1-1/4"
		365672	1-7/16"
		365673	1-1/2"
		978150	1-9/16"
		978151	1-5/8"
		978152	1-3/4"
		978153	1-11/16"
404, 405 TP, TPA	RU	978154	1-3/16"
		978155	1-1/4"
		365674	1-7/16"
		365675	1-1/2"
		978156	1-9/16"
		365676	1-11/16"
		918157	1-13/16"
404, 405, TP, TPA	LU, TU	365677	1-7/16"
		365678	1-1/2"
		978158	1-9/16"
		978159	1-5/8"
		365679	1-11/16"
		978160	1-3/4"
		978161	1-7/8"
		365680	1-15/16"

† All marks shown within this document are properties of their respective owners.



MODIFIABLE PRICING INSTRUCTIONS



44. STEADY BUSHING (continued)

STEADY BUSHING PART NUMBERS

FRAME	TYPE	KIT PART NUMBER	BORE SIZE
444, 445, 447 TP, TPA	LU, TU	2070898	1-3/16"
		2070899	1-7/16"
		2070900	1-1/2"
		2070901	1-9/16"
		2070902	1-5/8"
		2070903	1-11/16"
		2070904	1-3/4"
		2070905	1-7/8"
		2070906	1-15/16"
H444, H445 447 TP, TPA	RU	978162	1-5/16"
		365677	1-7/16"
		365678	1-1/2"
		365679	1-11/16"
		978160	1-3/4"
		365680	1-15/16"
		978163	2-1/8"
		365681	2-3/16"
		365682	2-1/4"
449	HU, JU	970273*	1.688"
		970274*	1.938"
		970275*	2.125"
		970276*	2.188"
		970277*	2.375"
		970278*	2.438"
		970279*	2.500"
5008, 5012,+ P, PH, PA	RU	2037052	1-11/16"
		2037054	1-15/16"
		2037055*	2-1/8"
		2037056	2-3/16"
		2037057*	2-1/4"
		2037058*	2-3/8"
		2037059	2-7/16"
		2037060*	2-1/2"
5807, 5809, 5811	JU	968595-165	1-11/16"
		968595-194	1-15/16"
		968595-000	2-3/16"
		968595-225	2-1/4"
		968596-000	2-7/16"
		993624-000	2-11/16"
5812, 5813	JU,RU	2006544-219	2-3/16"
		2006544-244	2-7/16"
		2006544-269	2-11/16"
		2006544-275	2-3/4"
		2006544-294	2-15/16"
		2006544-319	3-3/16"
		2006544-344	3-7/16"
		2006544-388	3-7/8"

* Product listed may not be available from stock
 +5012 Oil - Oil design max bore diameter of 2 1/2"



MODIFIABLE PRICING INSTRUCTIONS



45. SURGE PROTECTION

- Available for, WPI, WPIL and TEFC enclosures in 447 through the 9600 frame as motor mounted.
- Do not use this accessory on applications where motor is driven by an inverter. Serious damage to the VFD will result. Consult your drive supplier.
- Suitable oversized main conduit box is included in price adders shown.
- Hazardous location motors require a special conduit box and mandatory approval by the Inquiry Group. When approved, add \$39,366 list (for suitable conduit box only) in addition to the price adders shown on the next page.

Surge capacitors and lightning arrestors protect the motor winding from transient voltage spikes and from the incoming distribution system. Distribution system conditions likely to cause turn-to-turn or turn-to-ground winding damage include lightning strikes, capacitor switching, and opening or closing of the system circuit breaker, among others. Should the magnitude of stresses imposed on the winding from system voltage transients exceed the surge limits the motor can withstand, the insulation system will fail.

Lightning arrestors limit the magnitude of the transient voltage spike. This is achieved by the arrestor conducting to ground when the voltage reaches a given value. Surge capacitors limit the rate of rise of the voltage. This is achieved by the capacitor momentarily absorbing the steep wave front.

Surge protection is most effective when it is mounted directly from the main conduit box at the motor leads. Increasing this distance beyond 3 feet significantly reduces its effectiveness. Fusing the capacitors or arrestors is not recommended due to the difficulty in determining if or when the fuse is blown.

To provide surge protection, make the appropriate list price adder from below:

MOTOR VOLTAGE	SURGE CAPACITORS AND LIGHTNING ARRESTORS
460	\$8,554
2300	\$21,568
4160	\$28,317
6600	\$36,796

46. TEMPERATURE RISE -- STANDARD AND OPTIONAL

- This option may not be available on the maximum HP rating in a given frame size. Consult the Inquiry Group for availability.
- This option may change motor frame size and performance characteristics. Consult the Inquiry Group for confirmed data.
- Combined with other design altering modifications (high ambient, high altitude, VFD use, etc.), this option will significantly change listed product performance described in this catalog. Consult the Inquiry Group for confirmed frame size, performance data, etc.
- The description of this product feature assumes the motor is applied to sine wave power and in accordance with NEMA standards (standard ambient, altitude, balanced voltage, etc.).

The standard insulation system supplied on all Nidec Motor Corporation products described in this catalog is Class F. When our Class F system is subjected to insulation life testing as described in IEEE 275, it significantly exceeds the thermal capabilities required to classify it as capable of providing 20,000 hours of design life when operated at the Class F thermal limit of 155°C. Chart 47-1 indicates the thermal capabilities of our standard insulation system, which is shown as the diagonal line slightly below Class H.



MODIFIABLE PRICING INSTRUCTIONS



46. TEMPERATURE RISE (continued)

CHART 47-1

TYPICAL TEMPERATURE VERSUS LIFE CURVES FOR INSULATION SYSTEMS

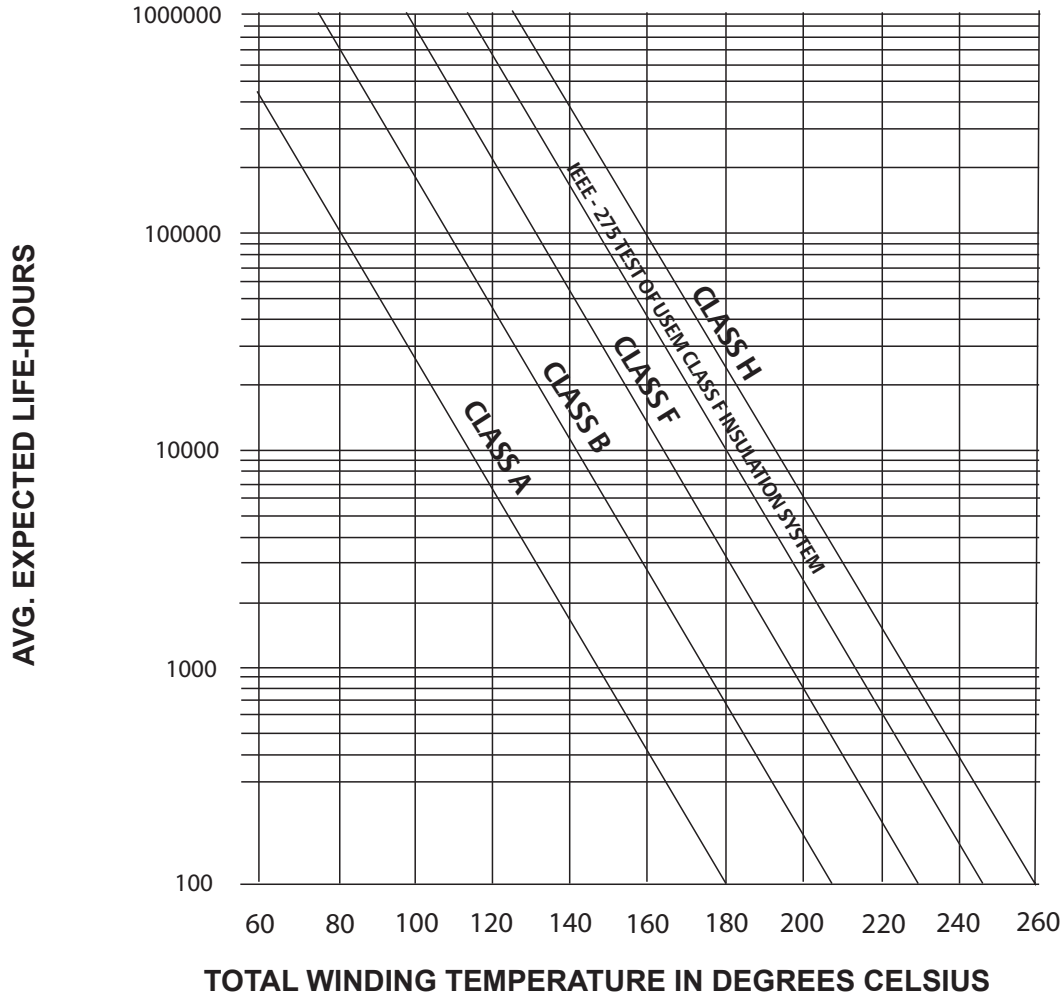

Most products described in this catalog are designed to operate at Class B temperature rise (80°C measured by resistance) when loaded to nameplate HP in a 40°C ambient under sine wave power. When the motor is run up to the 1.15 SF load point, standard temperature rise is Class F. Generally, products that deviate from this basic design philosophy are so noted on their perspective pricebook pages. This information is stated in general terms due to the wide variety of products and modifications listed in this catalog.



MODIFIABLE PRICING INSTRUCTIONS



46. TEMPERATURE RISE (continued)

IEEE standards assume winding design life doubles with a 10°C decrease in temperature rise and is halved with a 10°C increase. An insulation system operating at its thermal limit has a design life of 20,000 hours (about 2.3 years). Considering the standard thermal limits for Class F for 155°C and our design practice of 130°C total temperature rise under load, Nidec Motor Corporation provides about 100,000 hours -- 5 times the industry standard -- of winding life. This is one reason there are so many old U.S. MOTORS® verticals still in operation today.

INSULATION CLASS:	A ⁽¹⁾	B	F	H
Ambient temperature (for options see item 3 on page M-5)	40°C	40°C	40°C	40°C
Temperature rise at nameplate H.P. (for options see item 46 page M-68)	60°C	80°C	105°C	125°C ⁽²⁾
Hot spot or service factor allowance (for service factor see item 37 page M-51)	10°C	10°C	10°C	15°C
Thermal limit of insulation system (3)	105°C	130°C	155°C	180°C
NOTES: ⁽¹⁾ Class A insulation is shown for reference only and is not commercially available from Nidec Motor Corporation. ⁽²⁾ Class H insulation is offered for special ambient conditions, life requirements, etc. Class H temperature rise is not available or used by Nidec Motor Corporation. ⁽³⁾ Each insulation class provides the same winding design life when operated at its thermal limit.				

Any deviation from Insulation Class standards stated on individual pricebook pages requires the appropriate modification adder and may impact frame size and performance characteristics.

OPTIONAL TEMPERATURE RISE ADDITIONS

- Class B temperature rise at 1.15 SF measured by the resistance method.

FRAME SIZE	182 184	213 215	254 256	284 286	324 326	364 365	404 405	444 445, 447	449	5000-9600
LIST PRICE	\$164	\$469	\$469	\$728	\$939	\$1,878	\$2,559	\$3,521	\$5,664	12%*

*Without frame series jump (5000 to 5800) confirm with the Inquiry Group. If frame jump is required, build price from confirmed frame size without above price adder.

- Class B temperature rise at 1.0 SF measured by the embedded detector method (Class F rise at 1.15 SF -- follow above price guidelines).



† All marks shown within this document are properties of their respective owners.

MODIFIABLE PRICING INSTRUCTIONS

TEMPERATURE
RISE
TESTING

46. TEMPERATURE RISE (continued)

- Class B temperature rise at 1.15 SF measured by the embedded detector method -- Build entire motor price from next larger HP rating and add for 1.15 SF as shown above. Confirm frame and performance with the Inquiry Group. Confirm net price with St. Louis Marketing Services.
- Class A temperature rise -- NEMA^{®†} frame size only -- 60°C measured by resistance at nameplate HP price as premium efficiency (RUS/TUS) and add 7% list. For TITAN[®] motors-- Refer to the Inquiry Group.
- All other requirements -- Consult the Inquiry Group.

47. TERMINAL CONNECTORS (LEAD LUGS)

- 182 through 286 frame sizes are supplied with motor leads arranged (stripped back) to accommodate but less terminal connectors. Should a customer require factory-installed, ring-type lead lugs on a production motor, add \$178 list.
- 324 through 9600 frames are equipped with ring-type compression lead lugs as standard.
- Consult the Inquiry Group with other requirements.

48. TESTING (LIST PRICING)

All completely assembled motors receive a production test prior to shipment from the factory. This test confirms conformance to Nidec Motor Corporation design and no specific values are recorded. The exact nature of this test varies by motor type, but as a minimum, the motor is run at no load and visually inspected. There is no extra charge for a production test, and this test requirement does not need to be noted at order entry. Other testing is available as follows:

- Short Commercial Test (meets NEMA MG1-12.55 or Part 20 for Titan motors) -- This test consists of no-load current, locked rotor current, winding resistance, and high potential.
- Short Commercial Test Witnessed -- A short commercial test, as described above, performed in the presence of a witness.
- Complete Initial Test -- Nidec Motor Corporation tests per IEEE Standard 112, method B, dynamometer test. This test consists of full-load heat run, percent slip, no-load current, full-load current, locked rotor current, lock rotor torque, breakdown torque (calculated), efficiency and power factor at 100%, 75%, and 50% full load, insulation resistance per IEEE Standard 43, winding resistance and high potential. (For 460V ratings, testing limited to 700 HP and less.)
- Sound Test -- This is a no-load test performed in accordance with ANSI S12.51 and NEMA MG-1. For details on how this is performed, refer to Product Facts.



MODIFIABLE PRICING INSTRUCTIONS

TESTING

48. TESTING (LIST PRICING) (continued)

- Sound Test Witnessed -- A sound test, as described above, performed in the presence of a witness.
- Vibration and Special Testing -- Refer to the Inquiry Group for details and capabilities.
- Polarization Index -- In accordance with IEEE Standard 43. Dielectric absorption ratio.
- Spray test -- Form wound stator with Everseal Insulation System. Requires prior engineering approval.
- Inverter with motor -- Refer to the Inquiry Group for engineering and plant approval.
- Calibrated Test -- Same as complete initial but curves are provided to customer.

DESCRIPTION TESTS (LIST PRICING PER MOTOR):	182 184	213 215	254 256	284 286	324 326	364 365	404 405	444 445	447
Short commercial, unwitnessed	\$235	\$235	\$235	\$235	\$235	\$235	\$235	\$235	\$235
Short commercial, witnessed	\$675	\$675	\$675	\$675	\$675	\$675	\$675	\$675	\$675
Complete initial, unwitnessed @	\$1,385	\$1,385	\$1,385	\$1,385	\$2,136	\$2,770	\$3,263	\$4,531	\$4,531
Complete initial, witnessed @	\$2,113	\$2,113	\$2,113	\$2,113	\$3,263	\$4,155	\$4,906	\$6,784	\$6,784
Sound test, unwitnessed @	\$1,502	\$1,502	\$1,502	\$1,502	\$1,502	\$1,878	\$2,113	\$2,347	\$2,347
Sound test witnessed @	\$2,254	\$2,254	\$2,254	\$2,254	\$2,254	\$2,817	\$3,169	\$3,521	\$3,521
RCF Test unwitnessed	\$1,502	\$1,502	\$1,502	\$1,502	\$1,502	\$1,878	\$2,113	\$2,347	\$2,347
RCF Test witnessed	\$2,254	\$2,254	\$2,254	\$2,254	\$2,254	\$2,817	\$3,169	\$3,521	\$3,521
Vibration (2x witnessed)	\$704	\$704	\$704	\$704	\$704	\$704	\$704	\$704	\$704
Polarization test, unwitnessed	\$1,502	\$1,502	\$1,502	\$1,502	\$1,502	\$1,878	\$2,113	\$2,347	\$2,347
Polarization test, witnessed	\$2,113	\$2,113	\$2,113	\$2,113	\$2,113	\$2,817	\$3,169	\$3,521	\$3,521
Sealed Winding Immersion Test*	Not Available								
Inverter with motor	Refer to the Inquiry Group								

DESCRIPTION TESTS (LIST PRICING PER MOTOR):	449	5000	5800	6812 (TE)	6800-8000	9600
Short commercial, unwitnessed	\$235	\$235	\$235	\$235	\$235	\$235
Short commercial, witnessed	\$675	\$675	\$1,000	\$1,350	\$1,350	\$1,350
Complete initial, unwitnessed @	\$8,350	\$8,350	\$8,350	\$11,700	\$11,700	\$11,700
Complete initial, witnessed @	\$16,700	\$16,700	\$16,700	\$23,350	\$23,350	\$23,350
Sound test, unwitnessed @	\$2,347	\$2,347	\$3,852	\$4,270	\$4,270	\$5,129
Sound test witnessed @	\$3,521	\$3,521	\$6,406	\$6,406	\$6,406	\$7,981
RCF Test unwitnessed	\$2,347	\$2,347	\$3,852	\$4,270	\$4,270	\$6,608
RCF Test witnessed	\$3,521	\$3,521	\$6,406	\$6,406	\$6,406	\$7,981
Vibration test, unwitnessed	\$3,592	\$3,592	\$3,592	\$3,592	\$3,991	\$3,991
Vibration test, witnessed	\$5,986	\$5,986	\$5,986	\$5,986	\$7,981	\$7,981
Polarization index, unwitnessed	\$2,347	\$2,347	\$2,347	\$2,347	\$2,347	\$2,347
Polarization index, witnessed	\$3,521	\$3,521	\$3,521	\$3,521	\$3,521	\$3,521
Sealed Winding Immersion Test* (+50% witnessed)	\$9,272	\$9,272	\$9,272	\$9,272	\$9,272	\$9,272
Inverter with motor	Refer to Inquiry Group					

NOTE:

@ Multiply net test charge by 1.50 for multispeed motors tested at both speeds.

* Form wound motors with Everseal only.



† All marks shown within this document are properties of their respective owners.

MODIFIABLE PRICING INSTRUCTIONS



49. THERMAL PROTECTION

Selection of an accessory designed to provide thermal protection of bearings or windings depends upon the desired function the device is to perform. The table below provides a comparison of their various characteristics.

	SWITCH (RELAY)	INDICATOR & SWITCH	THERMOMETER	THERMOSTATS	RTD	THERMOCOUPLE	THERMISTOR
				KLIXON			
BRAND REF.	1	2	3	4	5	6	7
WHERE USED	BRG	BRG	BRG	WDG	BOTH	BOTH	WDG
ALARM	YES	YES	NO	YES	YES ²	YES ²	YES
SHUT DOWN	YES ^a	YES ^a	NO	YES ^a	YES ^b	YES ^b	YES ^a
AUTO RESET	YES	YES	NO	YES	NO	NO	NO
TEMPERATURE INDICATING	NO	YES	YES	NO	YES ^b	YES ^b	NO
RANDOM WOUND	---	---	---	YES	YES ^c	YES	YES
FORM WOUND	---	---	---	YES	YES	YES	LIMITED EFFECTIVENESS
OPERATE AUXILIARY EQUIPMENT	YES	YES	YES	YES	YES ^b	YES ^b	YES ^b
TYPE OF PROTECTION	I	I	I	B-G	A-H	A-H	A-H

NOTES:

Brand reference - typical factory choice as follows:

- 1 - Barksdale MT1H[†] or equal (Applicable to oil lubricated bearings only)
- 2 - United Electric Controls Series 800[†] or equal (Applicable to oil lubricated bearings only)
- 3 - Rochester gauges[†] - 3 inches stainless-steel dial or equal (Applicable to oil lubricated bearings only)
- 4 - Texas Instruments[†] or equal
- 5 - MINCO, RTD Co.[†] or equal
- 6 - MINCO, RTD Co.[†] or equal
- 7 - USEM Therma Sentry[†]

QUALIFICATION FOOTNOTES

- a) Requires connection to motor control relay
- b) Requires auxiliary monitor or controller not (normally) supplied with motor
- c) Limited availability



MODIFIABLE PRICING INSTRUCTIONS

THERMAL
PROTECTION

49. THERMAL PROTECTION (continued)

• TYPE OF PROTECTION PROVIDED

A. Locked Rotor

This type of protection is only available for random wound motors and is dependent on two variables. 1) The response time of the circuits beyond our detectors (or in the case of THERMA SENTRY®, beyond our controller), and 2) The particular motor design.

B. Running Overload (thermal considerations only)

C. Abnormally High Ambient

D. Voltage Unbalance

E. High or Low Voltage

F. Ventilation Failure

G. Single Phasing

H. Starting Overload

I. Alarm or Shutdown to Prevent Catastrophic Failure

A. BEARING THERMAL PROTECTION

THERMOWELLS

Thermowells are not an available option on NEMA®† or TITAN® motors. Thermowells are specifically designed to protect probes from pressure, flow and corrosion when the probe is submerged in this environment. None of these conditions exist in their application to NEMA®† or TITAN® motors.

NEMA® FRAME

One bearing protective device is available on the upper bracket and one on the lower bracket of WPI, high-thrust motors in the 320 through 447 frames and 404 through 447 frame TEFC (non-Hazardous location). Refer to the Inquiry Group for availability on other motor types and enclosures.

TITAN® FRAME

One bearing protective device is available on each bracket of TEFC, high-thrust motors in the 449 through 6812 frames. One bearing protective device is available on each bracket of open, high-thrust motors in the 5008 through 9608 frames. One bearing RTD is available on each end bracket of hazardous location, high-thrust motors in the 449 through 6812 frames. Bearing protective devices are not available on hazardous location normal-thrust TITAN® motors. Refer to the Inquiry Group for availability on other motor types and enclosures.



MODIFIABLE PRICING INSTRUCTIONS

**THERMAL
PROTECTION
(BEARINGS)**

49. THERMAL PROTECTION (continued)

A. BEARING THERMAL PROTECTION

TYPE OF DETECTOR	LIST PRICE ADDERS	
	ONE BEARING	TWO BEARINGS
Arrange for - but less detector	\$525	\$1,050
Thermocouple*		
- Copper-Constantan (Type T)	\$590	\$1,180
- Iron-Constantan (Type J)	\$590	\$1,180
- Chromel-Constantan (Type E)	\$590	\$1,180
- Chromel-Alumel (Type K)	\$590	\$1,180
Bearing Temperature Switch (Relay)*	\$590	\$1,180
- Barksdale Standard Enclosure		
Bearing Temperature Indicator and Switch*	\$1,340	\$2,680
- UE dial type with or without alarm contacts		
Stem Type Thermometer*	\$1,340	\$2,680
Resistance Temperature Detector		
- 10 OHM Copper RTD	\$1,340	\$2,680
- 120 OHM Nickel RTD	\$1,340	\$2,680
- 100 OHM Platinum RTD (TCR of .00392)	\$2,150	\$4,300
- 100 OHM Precision Platinum RTD (TCR of .00385)	\$2,910	\$5,820
BEARING RTD SET POINTS	FOSSIL OIL	SYNTHETIC OIL
WARNING	80°C	110°C
ALARM	90°C	120°C
SHUT-DOWN	100°C	130°C

**Not available on hazardous location*



MODIFIABLE PRICING INSTRUCTIONS

**THERMAL
PROTECTION
(WINDINGS)**

49. THERMAL PROTECTION (continued)

B. WINDINGS

- Not all options are available on all frame sizes
- For two winding multispeed motors, double list price adder shown below.
- For air temperature sensor (RTD) in WPII 6800, 8000 or 9600 frame motors, add \$1,897 list (NEMA 4 conduit head).

1. Winding Thermostats

Snap action, bimetallic, temperature actuated switches installed in the connection end-turns of the motor winding. Their purpose is to activate a warning device (N.O.) or shut down the motor (N.C.) upon excessive winding temperatures. Leads are normally brought out to the main conduit box on 460 volt motors. They are available with normally closed contacts for automatic reset. Overheat protectors with normally open contacts, for use in alarm or warning circuits, are available when specified at time of order. Double for hazardous location.

FRAME SIZE	182	213	254	284	324	364	404	444	447	449
	184	215	256	286	326	365	405	445		
LIST PRICE	\$89	\$89	\$89	\$146	\$207	\$308	\$308	\$308	\$308	\$408

FRAME SIZE	5000	5800	6812 (TE)	6800-8000	9600
LIST PRICE	\$408	\$725	\$725	\$725	\$725

2. Winding Thermistors (Embedded in winding)

- This accessory will not work without a control module. Our standard thermistors are SIEMENS^{®†} type B59155. Three thermistors are installed in the winding with 6 leads brought to the main conduit box. Control module is by others.
- To prevent nuisance tripping when this accessory is applied to reduced voltage starters, a timer in the control circuit should be added in the control circuit and set for 1-2 seconds. This will allow the motor to start when the auto signal is received (see diagram under THERMA SENTRY[®] description).
- This accessory provides NEMA^{®†} Type 1 (winding - running and locked rotor over temperature) protection for motors in the 182 through 447 frame size.
- This accessory provides NEMA^{®†} Type 2 (winding - running over temperature) protection only for TITAN[®] large frame (449 - 9608) motors.
- Thermistors are embedded in the winding end turns during manufacturing and cannot be easily added through conversion.



† All marks shown within this document are properties of their respective owners.

MODIFIABLE PRICING INSTRUCTIONS



49. THERMAL PROTECTION (continued)

B. WINDINGS

Winding thermistors are a nonlinear resistance temperature detector made of semiconductor material and embedded in the end turns of the motor winding, one per phase. Nidec Motor Corporation offers only SIEMENS® PTC type (Positive Temperature Coefficient) thermistors. NTC type thermistors are not available.

LIST PRICE ADDERS FOR THREE THERMISTORS ONLY

DESCRIPTION	FRAME SIZE									
	182 184	213 215	254 256	284 286	324 326	364 365	404 405	444 445	447	449 THROUGH 9600
THERMISTOR	\$472	\$472	\$472	\$669	\$669	\$876	\$876	\$876	\$876	\$1,303

Control module is not included.

3. THERMA SENTRY® SYSTEM

- Refer to notes listed under B.2 thermistors (disregard first note - THERMA SENTRY® includes control module).

THERMA SENTRY® Mode of Operation

The temperature sensor in the THERMA SENTRY® is a PTC thermistor. Its resistance increases non-linearly with temperature. When the motor winding reaches the critical shutdown point (knee of curve), there is a sharp rise in resistance.

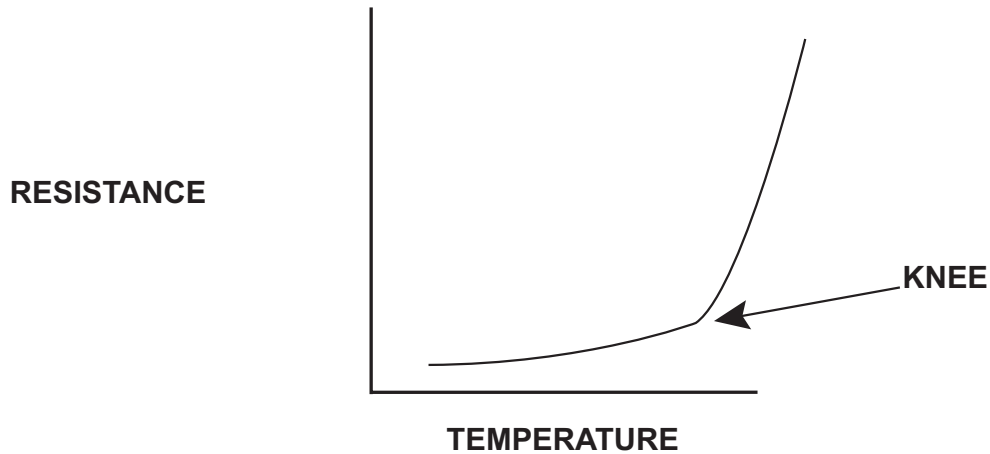

MODIFIABLE PRICING INSTRUCTIONS

**THERMAL
PROTECTION
WINDINGS**

49. THERMAL PROTECTION (continued)

B. WINDINGS

The THERMA SENTRY® winding protection consists of three Positive Temperature Coefficient (PTC) thermistors, one per phase, embedded in the end turns with six leads brought to the motor conduit box and a control for remote mounting by the customer. It protects against the most common causes of motor failure, including: high or low supply voltage, unbalanced line voltage, single phase conditions, abnormally high ambient temperatures, blocked ventilation, starting overload, and running overloads. The control module is supplied with one normally open and normally-closed contact (N/C). **The control module must be separately excited by a 24 to 240 AC/DC voltage source.**

The THERMA SENTRY® control module is available for remote mounted in the customer's control panel.

List price adders:

THERMA SENTRY® OPTIONS	Frame Size		
	180-360	400-447	449 & up
THERMA SENTRY® system (separately mounted / separately excited)	\$1,410	\$1,410	\$1,755
THERMA SENTRY® system (motor mounted / separately excited)	N/A	\$2,880	\$2,880

- Time-out circuit for THERMA SENTRY® used with reduce voltage starting.

There are many possible ways to provide a time-out scheme to the starting circuit. One simple, inexpensive option is shown below:

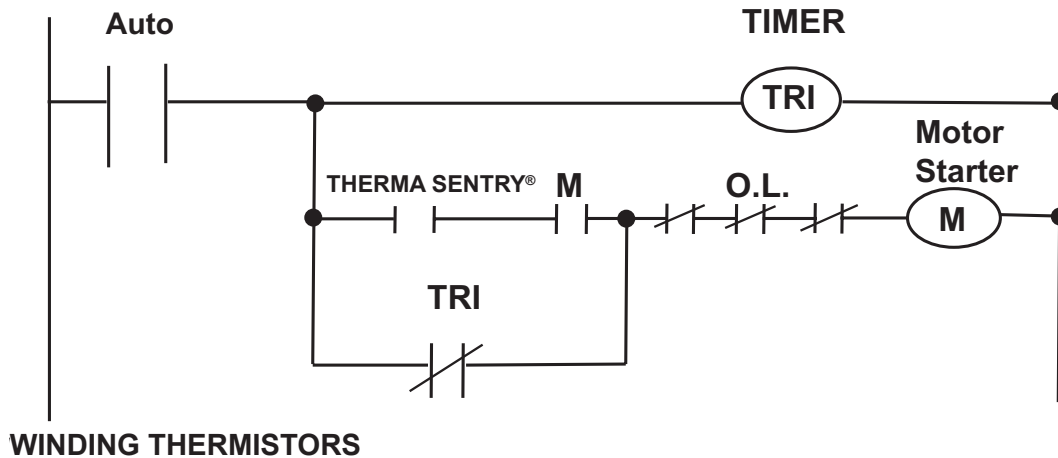

MODIFIABLE PRICING INSTRUCTIONS



49. THERMAL PROTECTION (continued)

B. WINDINGS

4. WINDING THERMOCOUPLES

- Winding thermocouples are available in the 324 through 9608 frame sizes.

A thermocouple consists of two dissimilar conductors welded together into a junction. This is inserted into the motor winding -- 2 per phase / 6 per motor. Thermocouple leads are brought out to terminal strip connections in an accessory conduit box, which is included in its price. These accessory signal wires leads are connected to an input instrument (supplied by others) to form a reference junction. Heating of the thermocouple imbedded in the winding generates a thermoelectric potential (EMF) proportional to the temperature difference between the two points, indicating the temperature of the embedded thermocouple.

LIST PRICE ADDITION FOR WINDING THERMOCOUPLES

THERMOCOUPLE TYPE	PRICE ADDITION	
	320-447 Frame	449-9600 Frame
- Copper-Constantan (Type T)	\$2,545	\$3,440
- Iron-Constantan (Type J)	\$2,545	\$3,440
- Chromel-Constantan (Type E)	\$2,545	\$3,440
- Chromel-Alumel (Type K)	\$2,545	\$3,440

- Control monitor is not furnished by Nidec Motor Corporation.
- This accessory may impact motor efficiency levels on premium efficiency products due to the extremely high stator slot fill of specific designs. Consult the Inquiry Group if questions exist.

5. WINDING RESISTANCE TEMPERATURE DETECTORS (RTDs)

Winding RTDs are available in the 324 through 9608 frame sizes (non-Hazardous location).

An RTD is a sensing element consisting of a precision wound wire coil of pure metal. Recognized for their accuracy, the RTD's resistance increases with temperature rise in a known and highly repeatable manner. Two RTDs per phase/6 per motor are our standard offering. Accessory lead (signal) wires are connected to terminal strip connectors in an accessory conduit box. When connected to an input instrument or monitor, RTD temperature can be monitored. A variety of RTDs are offered to industry standard curves as shown below. Must be specified at time of order entry.

RTD ELEMENT	NO. OF WIRES	RESISTANCE	PRICE ADDITION	
			320-447 Frame	449-9600 Frame
NICKEL (1)	2	120 OHMS @ 0°C	\$2,545	\$3,440
COPPER	3	10 OHMS @ 25°C	\$2,545	\$3,440
PLATINUM (2)	3	100 OHMS @ 0°C	\$3,825	\$5,165
PRECISION PLATINUM (3)	3	100 OHMS @ 0°C	\$4,955	\$6,690
NICKEL/IRON	2	676 OHMS @ 25°C	\$2,545	\$3,440

- (1) USEM standard supply if not specified at time of order.
- (2) TCR rating of .00392
- (3) TCR rating of .00385 (DIN & IEC STD.)

- Monitor or control module is not furnished by Nidec Motor Corporation.
- This accessory may impact motor efficiency levels on certain premium efficiency products due to their extremely high stator slot fills. Consult the Inquiry Group if questions exist.



† All marks shown within this document are properties of their respective owners.

MODIFIABLE PRICING INSTRUCTIONS

TOLERANCES

50. (SPECIAL) TOLERANCES

Nidec Motor Corporation can provide special mounting tolerances on vertical solid shaft motors as opposed to those noted on standard dimension prints supplied in this catalog. The following tables summarize the standard and special tolerances available.

Vertical Solid Shaft Special Mounting Tolerances

STANDARD TOLERANCES

	Through 447 Frame		449 Frame and Larger			
Bracket "AK" dimension	8.25"	13.50"	13.50"	22.00"	26.00"	33.75"
Shaft Runout	0.002	0.002	0.003	0.003	0.003	0.003
Face Runout	0.004	0.007	0.007	0.007	0.009	0.009
Register Runout	0.004	0.007	0.007	0.007	0.009	0.009
End Play	*	*	0.010	0.010	0.010	0.010

SPECIAL "1/2 NEMA" Tolerances

	Through 447 Frame		449 Frame and Larger			
Bracket "AK" dimension	8.25"	13.50"	13.50"	22.00"	26.00"	33.75"
Shaft Runout	0.001	0.001	0.0015	0.0015	0.0015	0.0015
Face Runout	0.002	0.0035	0.003	0.0035	0.0045	0.0045
Register Runout	0.002	0.0035	0.0035	0.0035	0.0045	0.0045
End Play	*	*	0.010	0.010	0.010	0.010

List price additions for special tolerances on vertical solid shaft motors

FRAME SIZE	182	213	254	284	324	364	404	444	449	5800	6812	6800	9600
	184	215	256	286	326	365	405	445	5000		(TE)	8000	
LIST ADDER	\$704	\$704	\$704	\$704	\$939	\$1,232	\$1,408	\$1,761	\$3,521	\$4,401	\$5,282	\$7,512	\$7,512

API-610 TOLERANCES

	Through 447 Frame		449 Frame and Larger			
Bracket "AK" dimension	8.25"	13.50"	13.50"	22.00"	26.00"	33.75"
Shaft Runout	0.001	0.001	0.001	0.001	0.001	0.001
Face Runout	0.001	0.001	0.001	0.001	0.001	0.001
Register Runout	0.004	0.004	0.004	0.004	0.004	0.004
End Play	*	*	0.005	0.005	0.005	0.005



† All marks shown within this document are properties of their respective owners.

MODIFIABLE PRICING INSTRUCTIONS



50. (SPECIAL) TOLERANCES (continued)

List price additions for API-610 tolerances on vertical solid shaft motors

FRAME SIZE	182 184	213 215	254 256	284 286	324 326	364 365	404 405	444 445 447	449 5000	5800	6812 (TE)	6800 8000	9600
LIST ADDER	\$939	\$939	\$939	\$939	\$1,291	\$1,643	\$1,878	\$2,347	\$4,695	\$5,869	\$7,042	\$9,977	\$9,977

*End play on high-thrust motors varies depending on the location of the thrust bearing.
 End play on motors with the thrust bearing in the lower bracket is typically set at .015" to .025"
 End play on motors with the thrust bearing in the upper bracket is typically set at .005" to .008"
Note: API-610 requires the motor thrust bearing on the upper end of the motor. In frame sizes where the thrust bearing is on the lower end, take exception on the bearing location and end play requirements.

51. THRUST -- MOMENTARY AND CONTINUOUS UPTHURST

Upthrust -- High-thrust motors. 30% momentary upthrust protection (of standard high-thrust value -- NOT extra-high-thrust value) can be provided at no extra charge and should be specified on order when desired. When upthrust protection is supplied on vertical HOLLOSHAFT® motors, the drive couplings must be bolted together and the self release feature will not apply; however, the nonreverse ratchet can be furnished (see price additions on standard price sheets).

For continuous upthrust in any amount, all frames, refer thrust values to the Inquiry Group for mandatory prior approval. When approved, add 7% list.

52. VIBRATION DETECTORS

- Nidec Motor Corporation offers a wide variety of seismic type vibration switches and transducers. However, we do not offer the corresponding monitoring equipment. The engineer or end user normally has well-defined monitoring system requirements that are the province of custom panel shops, not Nidec Motor Corporation. These are most effective when mounted on the upper bracket.
- Proximity probes or transducers are designed for use with horizontal sleeve bearing motors and are not available for use on vertical motors.
- Monitors and control units, cables, etc., are not included in prices. These are not supplied by Nidec Motor Corporation.
- Nidec Motor Corporation's standard vibration detector for non-classified areas is the Robertshaw®† model #366
- Nidec Motor Corporation's standard vibration detector for hazardous location ratings is the Metrix®† Model M5550
- Arrange to accommodate but less vibration detector -- add \$1,056 list each.
- Available on NEMA®† frame WPI motors in the 324-447 frames, upper bracket only.
- Available on NEMA®† frame TEFC motors in the 324 through 447 frame size, upper bracket only.
- Available on all TITAN® motor 449 through 9608 frame, upper bracket mounting.



† All marks shown within this document are properties of their respective owners.

MODIFIABLE PRICING INSTRUCTIONS

VIBRATION
DETECTORS

52. VIBRATION DETECTORS (continued)

Switches are normally self-contained (with internal contacts) and require no transmitter. Quantity-1 supplied as standard.

Group 1: Seismic switches, mechanical, acceleration sensitive.
Units of measure: Peak Gs (gravity units)

(STD) Robertshaw^{®†} model 366A8, and \$2,653 list each; for description see footnotes: A-D-H-J-K enclosure meets NEMA 4 specs.

Robertshaw^{®†} model 365A8, add \$5,235 list each; for description see footnotes: A-D-G-J-K

Robertshaw^{®†} model 376A, add \$6,573 list each; for description see footnotes: A-D-H-I-K enclosure meets NEMA 4 specs. (Must note desired time delay requirement on order)

Metrix^{®†} model 5550 add \$5,235 list each; for description see footnotes: A-D-G-J-L options: I (add \$320 list), K (add \$751 list).

Group 2: Seismic switches, electronic solid-state, Piezo-Electric velocity sensitive
Units of measure: IPS (inches/second)

Metrix^{®†} model 440S-R, add \$6,385 list each; for description see footnotes: A-C-H-I-K. Has 4-20 MA output for remote readout or computer interface.

Metrix^{®†} model 440D-R, add \$8,146 list each; for description see footnotes: B-C-H-I-K. Has 4-20 MA output for remote readout or computer interface.

All above detectors are available with hazardous location enclosures as indicated by a 450 model number. For this option add \$1,819 list to above price.

Group 3: Seismic probes, electronic solid-state, Piezo-Electric displacement sensitive
Units of measure: inches, peak to peak

Normally used on machines at 720 rpm and below where measurements in the acceleration or velocity mode may be low even for large displacement values.

This method is available as an alternate to all PMC/Beta detectors listed in Group 2. To include this feature in a detector listed above, use the same price structure noting on order the displacement requirement.

Seismic Transducers send signals to a transmitter that in turn sends the signals to relay, monitor, or control unit (not supplied by Nidec Motor Corporation).

Group 4: Seismic transducers, velocity sensitive
Units of measure: IPS (inches/second), see footnote F

IRD model 544M, add \$7,688 list each, cable not included.



MODIFIABLE PRICING INSTRUCTIONS



52. VIBRATION DETECTORS (continued)

Metrix^{®†} model ST 5484, add \$4,643 list each.

Metrix^{®†} model 162VTS, add \$4,643 list each.

Bently-Nevada^{®†} 330500 (Piezo-Electric) velomitor, add \$4,941 list each.

Bently-Nevada^{®†} 9200 seismoprobe, add \$5,235 list each.

Group 5: Seismic transducers, electronic, Piezo-Electric accelerometers
Units of measure: Peak Gs (gravity units), see Footnote E

Metrix^{®†} model SA6200, add \$5,669 list each.

Bently Nevada^{®†} model 330400, add \$5,094 list each.

Footnotes to the above:

- A. Alarm or shutdown -- not both
- B. Alarm and shutdown -- both
- C. Has indicating capacity
- D. Does not have indicating capability
- E. Transmitter required
- F. No transmitter required
- G. Hazardous location housing
- H. Weatherproof housing
- I. Time delay prevents nuisance tripping
- J. Does not have time delay capability
- K. Remote reset capability
- L. Does not have remote reset capability



MODIFIABLE PRICING INSTRUCTIONS

VOLTAGE

53. VOLTAGE, STANDARD AND SPECIAL

Standard voltages are described below. Price additions are shown below for special voltage options.

HP	PRICE ADDITIONS (PERCENT OF BASIC MOTOR PRICE)					
	198 TO 329 VOLTS	330 TO 600 VOLTS	601 TO 3000 VOLTS	3001 TO 4200 VOLTS	4201 TO 5000 VOLTS	5001 TO 7000 VOLTS
	% OF 460 BASE MOTOR PRICE			% OF 2300 VOLT BASE MOTOR PRICE		
100 & SMALLER	4% ◇	4% ◇	---	---	---	---
101 TO 200	4% ◇	4% ◇	---	---	---	---
201 TO 300	8%	4%	---	---	19%	48%
301 TO 700	12%	4%	4%	19%	19%	45%
701 TO 1000	19%	4%	4%	15%	15%	42%
1001 TO 1250	---	---	8%	13%	13%	39%
1251 TO 1750	---	---	12%	12%	12%	36%
1751 TO 5000	---	---	15%	11%	11%	33%

◇ For 50 hertz, 220/380 volt motors, use price of 440 volts, 50 hertz motor.

A. 60 cycle, 3 phase: 200, 230, 230/460, 460 and 575 volts are considered standard for ratings of 100 H.P. and below in maximum frame size of 405TP.

B. 60 cycle, 3 phase: 460, 575 volts -- both are considered standard for ratings listed on pricebook pages.

C. 50 cycle, 3 phase: 190, 220, 190/380, 380 and 415 volts are all considered standard for ratings of 100 H.P. and below and in a maximum frame size of 405 TP.

D. 50 cycle, 3 phase: 380, 415 volts -- both are considered standard voltage equivalents to those 60 cycle low voltage motors listed on pricebook pages noted above in item "B".

E. 200, 208, or 230 (60HZ); 190, 220 or 240 (50HZ) volts are not available without prior approval from the Inquiry Group on motors 200 H.P. and above. When approved, an oversize conduit box is also required in addition to a special voltage adder.

F. 60 cycle, 3 phase, medium voltage: 2300 and 2400 volts are considered base standard ratings. 4000 and 4160 are also standard at prices shown on modifiable pricebook pages.

G. Dual voltage ratings are available as either 2300/4000V or 2400/4160V. To price as dual voltage, use list price of 4000 or 4160 volt motor and specify dual voltage on face of order.

H. 60 cycle, 3 phase, 2300 volt motors are not available on ratings below 150 H.P.

I. 60 cycle, 3 phase, 4000 volt motors are not available on ratings below 150 H.P.

J. 60 cycle, 3 phase, 6000 to 6900 volt motors are not available below 200 H.P. Obtain Inquiry Group approval before quoting motors less than 350 H.P.

K. Voltages above 6900 volt are not available.



† All marks shown within this document are properties of their respective owners.

MODIFIABLE PRICING INSTRUCTIONS



54. LIMITED WARRANTY

Refer to usmotors.com website for the most up-to-date warranty information.

All Nidec Motor Corporation products shall carry the limited warranty of 12 months from the date of installation, not to exceed 18 months from date of manufacture as specified in Section 5 of the Nidec Motor Corporation's Terms and Conditions of Sale except those specifically listed below, or noted within individual product family pages within this catalog.

	Installed / Manufactured	Installed / Manufactured
Industrial Motors 140 - 447 Frames		
	Sine Wave Power	VFD Power
Standard / Energy	18 / 24 months	Not Covered
Premium Efficient & NEMA® Premium	36 / 42 months	12 / 18 months**
Inverter Duty	36 / 42 months	36 / 42 months
TITAN Motors - 449 Frame and Larger		
	Sine Wave Power	VFD Power
Premium Efficient	24 / 30 months	12 / 18 months**
Inverter Duty	24 / 30 months	24 / 30 months

**Must have Shaft Grounding Ring for bearings to be covered. See Warranty Guidelines for IHP Motors on VFDs for bearing exclusions on vertical motors.

Deferred & Extended Warranty Information

DEFERRED AND EXTENDED WARRANTIES (OPTIONAL WARRANTIES)

Deferred and extended warranties, defined as follows, apply only to 449 frame and larger horizontal and vertical motors, for use in the continental United States only. All optional warranties must be approved in writing by Nidec Motor Corporation. Contact Marketing for Approval.

Deferred Warranty

Nidec Motor Corporation's limited warranty, as set forth in the standard terms and conditions of sale, page x, shall apply subject to the following modification: for a 5% addition to the net price of the motor ("Net Adder"), the warranty period on the motor will be for a period of one year (or more for applicable products) from that date of initial operation, but not in excess of 60 months from the date of shipment subject to the following conditions:

1. That within thirty days prior to initial operation, a Nidec Motor Corporation (NMC) Service Engineer, or authorized NMC Service Station, be hired by the Buyer at Buyer's expense, to thoroughly inspect the motor to ascertain that the motor is in "as shipped" condition. This inspection will include but not be limited to:
 - a. Megger test of winding insulation.
 - b. Internal inspection to determine that the winding has not been damaged and that the motor is clean and dry.
 - c. Inspection of the bearings to determine they have not been damaged and there is no water in the oil reservoirs.
 - d. External inspection to determine that no damage has been made.
2. Make any corrections which this inspection shows to be needed because the motor has been in storage or standing idle. These corrections will be made at Buyer's expense if corrections required are due to causes other than defects in material or workmanship.
3. That an affidavit certifying that the motor has successfully passed the inspection and is in "as shipped" condition be supplied to NMC by Buyer. Failure to provide NMC with the affidavit certifying that the motor has passed inspection and is in "as shipped" condition will result in voiding the warranty.

Extended Warranty

When Buyer's specification requires a warranty period longer than the limited warranty set forth in Nidec Motor Corporation's standard terms and conditions of sale, page x, the net price of each motor will be increased according to the schedule, which follows. Nidec Motor Corporation may accept an order with up to 60 months coverage.

From Mfg. Date	From Install	Net Adder
30 months	24 months	2%
42 months	36 months	3%
54 months	48 months	5%
66 months	60 months	6%



NOMINAL FULL LOAD EFFICIENCIES

Nominal Full Load Efficiencies of Premium Efficient 60Hz $\leq 600V$ Motors

Open Motors				
HP	2 Pole	4 Pole	6 Pole	8 Pole
1	77.0	85.5	82.5	75.5
1.5	84.0	86.5	86.5	77.0
2	85.5	86.5	87.5	86.5
3	85.5	89.5	88.5	87.5
5	86.5	89.5	89.5	88.5
7.5	88.5	91.0	90.2	89.5
10	89.5	91.7	91.7	90.2
15	90.2	93.0	91.7	90.2
20	91.0	93.0	92.4	91.0
25	91.7	93.6	93.0	91.0
30	91.7	94.1	93.6	91.7
40	92.4	94.1	94.1	91.7
50	93.0	94.5	94.1	92.4
60	93.6	95.0	94.5	93.0
75	93.6	95.0	94.5	94.1
100	93.6	95.4	95.0	94.1
125	94.1	95.4	95.0	94.1
150	94.1	95.8	95.4	94.1
200	95.0	95.8	95.4	94.1
250	95.0	95.8	95.8	95.0
300	95.4	95.8	95.8	-
350	95.4	95.8	95.8	-
400	95.8	95.8	-	-
450	96.2	96.2	-	-
500	96.2	96.2	-	-

Enclosed Motors				
HP	2 Pole	4 Pole	6 Pole	8 Pole
1	77.0	85.5	82.5	75.5
1.5	84.0	86.5	87.5	78.5
2	85.5	86.5	88.5	84.0
3	86.5	89.5	89.5	85.5
5	88.5	89.5	89.5	86.5
7.5	89.5	91.7	91.0	86.5
10	90.2	91.7	91.0	89.5
15	91.0	92.4	91.7	89.5
20	91.0	93.0	91.7	90.2
25	91.7	93.6	93.0	90.2
30	91.7	93.6	93.0	91.7
40	92.4	94.1	94.1	91.7
50	93.0	94.5	94.1	92.4
60	93.6	95.0	94.5	92.4
75	93.6	95.4	94.5	93.6
100	94.1	95.4	95.0	93.6
125	95.0	95.4	95.0	94.1
150	95.0	95.8	95.8	94.1
200	95.4	96.2	95.8	94.5
250	95.8	96.2	95.8	95.0
300	95.8	96.2	95.8	-
350	95.8	96.2	95.8	-
400	95.8	96.2	-	-
450	95.8	96.2	-	-
500	95.8	96.2	-	-



NOMINAL FULL LOAD EFFICIENCIES

Nominal Full Load Efficiencies of Energy Efficient 60Hz $\leq 600V$ Motors

Open Motors				
HP	2 Pole	4 Pole	6 Pole	8 Pole
1	-	82.5	80.0	74.0
1.5	82.5	84.0	84.0	75.5
2	84.0	84.0	85.5	85.5
3	84.0	86.5	86.5	86.5
5	85.5	87.5	87.5	87.5
7.5	87.5	88.5	88.5	88.5
10	88.5	89.5	90.2	89.5
15	89.5	91.0	90.2	89.5
20	90.2	91.0	91.0	90.2
25	91.0	91.7	91.7	90.2
30	91.0	92.4	92.4	91.0
40	91.7	93.0	93.0	91.0
50	92.4	93.0	93.0	91.7
60	93.0	93.6	93.6	92.4
75	93.0	94.1	93.6	93.6
100	93.0	94.1	94.1	93.6
125	93.6	94.5	94.1	93.6
150	93.6	95.0	94.5	93.6
200	94.5	95.0	94.5	93.6
250	94.5	95.4	95.4	94.5
300	95.0	95.4	95.4	-
350	95.0	95.4	95.4	-
400	95.4	95.4	-	-
450	95.8	95.8	-	-
500	95.8	95.8	-	-

Enclosed Motors				
HP	2 Pole	4 Pole	6 Pole	8 Pole
1	75.5	82.5	80.0	74.0
1.5	82.5	84.0	85.5	77.0
2	84.0	84.0	86.5	82.5
3	85.5	87.5	87.5	84.0
5	87.5	87.5	87.5	85.5
7.5	88.5	89.5	89.5	85.5
10	89.5	89.5	89.5	88.5
15	90.2	91.0	90.2	88.5
20	90.2	91.0	90.2	89.5
25	91.0	92.4	91.7	89.5
30	91.0	92.4	91.7	91.0
40	91.7	93.0	93.0	91.0
50	92.4	93.0	93.0	91.7
60	93.0	93.6	93.6	91.7
75	93.0	94.1	93.6	93.0
100	93.6	94.5	94.1	93.0
125	94.5	94.5	94.1	93.6
150	94.5	95.0	95.0	93.6
200	95.0	95.0	95.0	94.1
250	95.4	95.0	95.0	94.5
300	95.4	95.4	95.0	-
350	95.4	95.4	95.0	-
400	95.4	95.4	-	-
450	95.4	95.4	-	-
500	95.4	95.8	-	-



QUICK ENGINEERING FACTS

BASE
DIAMETER

A. BASE DIAMETER DIMENSIONS AND FRAME SUFFIX NOMENCLATURE

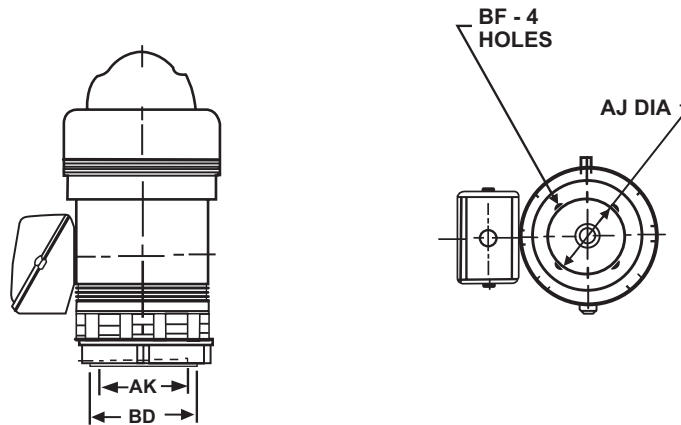

"BD" BASE DIAMETER	"AK" RABBET DIAMETER	"AJ" BOLT CIRCLE	"BF" BOLT HOLE	QTY "BF" HOLES
10.0	8.25	9.125	.438	4
12.0	8.25	9.125	.438	4
16.5	13.50	14.75	.688	4
20.0	13.50	14.75	.688	4
24.5	13.50	14.75	.688	4
24.5	13.50	22.00	.938	4 ⁽¹⁾
30.5	22.00	26.00	.813	4
36	26.00	32.00	1.00	4/8 ⁽²⁾
42	33.75	39.00	1.125	8
SPECIAL				

NOTES:

- (1) Alternate on 5800 frame TEFC only
- (2) 8 holes on 5813 VPA and 6800 PA
- (3) TP frame suffix is high-thrust HOLLOSHAFT®
- (4) VP frame suffix is high-thrust solid shaft
- (5) LP frame suffix is medium-thrust solid shaft (In-line)
- (6) HP frame suffix is normal-thrust solid shaft
- (7) P, PH, PA Titan solid or HOLLOSHAFT®



QUICK ENGINEERING FACTS

WP-I & WP-II

FRAME SIZE	STD. (BD) BASE DIA. INCHES	ALTER BD'S INCHES	MAX "BX" CPLG BORE	CD DIM. CPLG HEIGHT	TYPICAL SHIPPING WEIGHT IN LBS.		STEADY BUSHING KIT	
					WP-I	WP-II		
SINGLE PHASE MOTOR PRODUCT ONLY								
213P	10	---	1.001	17.56	162	NOT AVAILABLE	AVAILABLE.	
215P	10	---	1.001	17.56	186			
254P	10	12	1.001	23.38	250			
256P	10	12	1.001	23.38	275			
THREE PHASE MOTOR PRODUCT ONLY								
213TP	10	---	1.00	18.13	210	USE TEFC PRODUCT WHEN WP-II IS SPECIFIED	LOWER BEARING IS GREASE LUBE ON OPEN MOTORS AS STD. THROUGH THE WP1 447TP FRAME.	
215TP	10	---	1.00	18.13	210			
254TP	10	12/16.5**	1.25	23.38	320			
256TP	10	12/16.5**	1.25	23.38*	330			
284TP	10	12/16.5	1.25	24.75	370			
286TP	10	12/16.5	1.25	24.75	380			
324TP	16.5	12	1.501	28.22	635			
326TP	16.5	12	1.501	28.22	675			
364TP	16.5	12	1.501	31.16	730			
365TP	16.5	12	1.501	31.16	750			
404TP	16.5	20	1.688	36.94	1200			
405TP	16.5	20	1.688	36.94	1220			
444TP	16.5	20	2.251	44.78	1700			
445TP	16.5	20	2.251	44.78	1800			
447TP	20/16.5	24.5	2.251	49.78	2300			
449TP	24.5	20/30.5	2.251	49.78	3150			
5008P	24.5	20/30.5	2.501	57.06	4050			4400
5012P	24.5	20/30.5	2.751	72.30	5450			5900
5813P	30.5	36	3.875	93.13	10200			10700
6808P	30.5	36	3.875	80.06	8000	9150		
6810P	30.5	36	3.875	91.06	9350	10350		
6813P	30.5	36/42	3.875	111.66	19400	20500		
8005P	42	36	3.875	80.562	9400	10900		
8006P	42	36	3.875	84.562	11000	11900		
8007P	42	36	3.875	88.562	10600	12500		
8008P	42	36	3.875	92.562	12200	13000		
8009P	42	36	3.875	96.562	13300	14100		
8010P	42	36	3.875	100.562	14200	15100		
8011P	42	36	3.875	104.562	15100	16100		
8012P	42	36	3.875	108.562	15800	16600		
9601P	42	SEE MOD. SECTION	4.250	85.03	14500	15500		
9602P	42		4.250	89.03	15100	16100		
9603P	42		4.250	93.03	15800	16400		
9604P	42		4.250	97.03	16900	17700		
9605P	42		4.250	101.03	18000	18800		
9606P	42		4.250	105.03	19100	19900		
9607P	42		4.250	109.03	20200	21000		
9608P	42		4.250	113.03	21300	22100		

*Premium efficiency has 24.75" CD on this frame

**16.5" BD only available on Vertical HOLLOSHAFT® motors



† All marks shown within this document are properties of their respective owners.

QUICK ENGINEERING FACTS

TEFC & HAZARDOUS LOCATION

FRAME SIZE	STD. (BD) BASE DIA. INCHES	ALTER BD'S INCHES	MAX CPLG BORE	CD-CPLG HEIGHT TEFC	CD-CRLG HEIGHT X-PROOF	TYPICAL WEIGHT TEFC	TYPICAL SHIPPING WEIGHT C-DUTY	TYPICAL SHIPPING WEIGHT X-PROOF	STEADY BUSHING KIT
182TP	10	---	1.001	17.56	17.50	150	175	165	AVAILABLE
184TP	10	---	1.001	17.56	17.50	170	190	180	
213TP	10	---	1.001	17.56	17.50	210	230	220	
215TP	10	---	1.001	17.56	17.50	220	240	230	
254TP	10	12	1.251	22.94	22.94	320	430	400	
256TP	10	12	1.251	22.94	22.94	320	430	400	
284TP	10	12/16.5	1.251	26.56	26.56	330	450	420	
286TP	10	12/16.5	1.251	26.56	26.56	330	450	420	
324TP	16.5	12	1.501	28.50	28.50	720	800	740	
326TP	16.5	12	1.501	28.50	28.50	720	800	750	
364TP	16.5	---	1.751	30.0	30.0	1000	1050	1000	
365TP	16.5	---	1.751	30.0	30.0	1025	1075	1050	
404TP	16.5	---	1.938	39.93	39.94	1600	1750	1600	
405TP	16.5	---	1.938	39.93	39.94	1600	1750	1725	
444TP	16.5	20	1.937	43.06	42.50	2000	2200	2000	
445TP	16.5	20	1.937	43.06	42.50	2200	2200	2100	
447TP	16.5	20	1.937	46.56	46.00	2400	2600	2400	
449TP	24.5	20	2.501	56.88	56.88	3400	3600	---	
5008P	24.5	20	2.501	56.50	56.50	3700	3950	3700	
5807P	30.5	24.5	2.750	61.53	61.53	5800	6100	5800	
5809P	30.5	24.5	2.750	68.53	68.53	6800	7100	6900	
5811P	30.5	24.5	2.750	76.53	76.53	8000	8300	8000	
5812P	30.5	36	2.750	83.88	---	10200	10500	---	
6812P	42	30.5/36	2.75	98.3	---	17000	17000	---	

AVAILABLE

NOT AVAILABLE AS KITS. MFG'D PRODUCT ONLY



† All marks shown within this document are properties of their respective owners.

QUICK ENGINEERING FACTS



B. DECIMAL AND METRIC EQUIVALENTS

Fraction	(inch)	Decimal (inch)	mm	Fraction	(inch)	Decimal (inch)	mm	
1/32	1/64	0.01562	0.397	17/32	33/64	0.51562	13.097	
		0.03125	0.794				0.53125	13.494
	3/64	0.04688	1.191			35/64	0.54688	13.891
1/16		0.06250	1.588	9/16		0.56250	14.288	
	5/64	0.07812	1.984			37/64	0.57812	14.684
3/32		0.09375	2.381	19/32		0.59375	15.081	
1/8	7/64	0.10938	2.778	5/8	39/64	0.60938	15.478	
		0.12500	3.175				0.62500	15.875
	9/64	0.14062	3.572			41/64	0.64062	16.272
5/32		0.15625	3.969	21/32		0.65625	16.669	
	11/64	0.17188	4.366			43/64	0.67188	17.066
3/16		0.18750	4.763	11/16		0.68750	17.463	
7/32	13/64	0.20312	5.159	23/32	45/64	0.70312	17.859	
		0.21875	5.556				0.71875	18.256
	15/64	0.23438	5.953			47/64	0.73438	18.653
1/4		0.25000	6.350	3/4		0.75000	19.050	
	17/64	0.26562	6.747			49/64	0.76562	19.447
	9/32	0.28125	7.144			25/32	0.78125	19.844
5/16	19/64	0.29688	7.541	13/16	51/64	0.79688	20.241	
		0.31250	7.938				0.81250	20.638
	21/64	0.32812	8.334			53/64	0.82812	21.034
11/32		0.34375	8.731	27/32		0.84375	21.431	
	23/64	0.35938	9.128			55/64	0.85938	21.828
3/8		0.37500	9.525	7/8		0.87500	22.225	
13/32	25/64	0.39062	9.922	29/32	57/64	0.89062	22.622	
		0.40625	10.319				0.90625	23.019
	27/64	0.42188	10.716			59/64	0.92188	23.416
7/16		0.43750	11.113	15/16		0.93750	23.813	
	29/64	0.45312	11.509			61/64	0.95312	24.209
15/32		0.46875	11.906	31/32		0.96875	24.606	
1/2	31/64	0.48438	12.303	1/1	63/64	0.98438	25.003	
		0.50000	12.700				1.00000	25.400



† All marks shown within this document are properties of their respective owners.

QUICK ENGINEERING FACTS



C. DESIGN LETTER

The design letter that is assigned to a polyphase motor is defined by NEMA in Section MG1-16-1. The letter is a function of torques and locked amps exhibited by the motor. NEMA does not define values for every rating. If a rating is not contained within the NEMA “envelopes” shown below, it cannot have a design letter on the name-plate. Voltage is not a factor, only HP and speed. Note that multispeed have no design letter.

60 HZ							
HP	SYNCHRONOUS SPEED, RPM						
	3600	1800	1200	900	720	600	514
1/2	---	---	---				
3/4	---	---					
1	---						
1-1/2							
2							
3							
5							
7-1/2							
10-125, INCLUSIVE							
150							---
200							---
250							---
300-350							---
400-500, INCLUSIVE							---

50 HZ				
HP	SYNCHRONOUS SPEED, RPM			
	3600	1500	1000	750
1/2	---	---	---	
3/4	---	---		
1	---			
1-1/2				
2				
3				
5				
7-1/2				
10-125, INCLUSIVE				
150				
200				



QUICK ENGINEERING FACTS

SUPPLEMENTAL
INFORMATION

D. FORMULAS

- kW = hp x .746
- Torque in lb-ft = $\frac{\text{hp} \times 5250}{\text{rpm}}$
- Motor synchronous speed in rpm = $\frac{120 \times \text{Hz}}{\text{number of poles}}$
- Three-phase full-load amp = $\frac{\text{hp} \times .746}{1.73 \times \text{kV} \times \text{efficiency} \times \text{power factor}}$
- Rated motor kVA = $\frac{\text{hp} (.746)}{\text{efficiency} \times \text{power factor}}$
- kW loss = $\frac{\text{hp} (.746) (1.0 - \text{efficiency})}{\text{efficiency}}$
- Wk² referred to motor shaft speed = [driven machine Wk² $\frac{(\text{driven machine rpm})^2}{\text{motor rpm}}$] + gear Wk² at motor speed
- Accelerating time = $\frac{.462 (\text{Wk}^2 \text{ of motor and load}) \text{ rpm}^2}{\text{motor rated kW} \times 10^6 \times \text{per-unit effective accelerating torque}}$
- kVA in-rush = percent in-rush x rated kVA
- Approximate voltage drop (%) = $\frac{\text{motor kVA in-rush}}{\text{transformer kVA}} \times \text{transformer impedance (normally 5\% to 7\%)}$
- Stored kinetic energy in kW-sec = 2.31 x (total Wk²) x rpm² x 10⁷
- Inertia constant (H) in seconds = $\frac{\text{stored kinetic energy in kW-seconds}}{\text{hp} (.746)}$
- Conversion factors: CV = (metric hp) = 735.5 watts = 75 kg-m/sec Wk² (lb-ft) = 5.93 x GD² (kg-m²)
- Ventilating-air requirements: 100-125 cfm of 40°C air at 1/2-in. water pressure for each kW of loss
- Degrees C = (Degrees F-32) x $\frac{5}{9}$
- Degrees F = [(Degrees C) x $\frac{9}{5}$] + 32























QUICK ENGINEERING FACTS

INDEX OF PROTECTION

E. INDEX OF PROTECTION

DEFINITION

Protection Against Solid Objects			Protection Against Liquids			Mechanical Protection		
No.	Tests	Definition	No.	Tests	Definition	No.	Tests	Definition
0		No protection	0		No protection	0		No protection
1	 $\varnothing 50\text{mm}$	Protected against solid objects over 50mm (e.g. accidental hand contact)	1		Protected against vertically dripping water (condensation)	1		Impact energy: 0,225 J
2	 $\varnothing 12\text{mm}$	Protected against solid objects over 12mm (e.g. finger)	2	 15°	Protected against water dripping up to 15° from the vertical	2		Impact energy: 0,375 J
3	 $\varnothing 2.5\text{mm}$	Protected against solid objects over 2.5mm (e.g. tools, wire)	3	 60°	Protected against rain falling at up to 60° from the vertical	3		Impact energy: 0,500 J
4	 $\varnothing 1\text{mm}$	Protected against solid objects over 1mm (e.g. thin wire)	4		Protected against water splashes from all directions	4		
5		Protected against dust (no deposits of harmful material) ¹	5		Protected against jets of water from all directions ²	5		Impact energy: 2 J
6		Totally protected against dust. Does not involve rotating machines	6		Protected against jets of water comparable to heavy seas	6		
<p>Atmospheric Protection Index. Weatherproof construction reduces the penetration of rain, snow and airborne particles to a value compatible with the correction running of the machine. Indicated when the letter W is inserted between IP and index numbers.</p> <p>1. Motor protected against dust and accidental contact. Test result: No dust enters in harmful quantities; no risk of direct contact with rotating parts.</p> <p>2. Motor protected against jets of water from all directions from hoses at 3 m distance with a flow rate of 12.5 l/min at 0.3 bar. Test result: No damage from water projected onto the machine while in operation.</p> <p>3. Motor resistant to impacts of 6 joules (impact of a 1.5 kg hammer from a height of 0.4 meters). Test result: Damage caused by impacts does not affect the running of motor.</p>			7	 0.15 m	Protected against the effects of immersion to depths of between 0.15 and 1m	7		Impact energy: 6 J ³
			8	 ..m	Protected against the effects of prolonged immersion at depth	8		
			9			9		Impact energy: 20 J

The conditions and severity of the tests must be subject to a specific agreement between the manufacturer and the end user.



† All marks shown within this document are properties of their respective owners.

F. LONG-TERM STORAGE FOR MOTORS WITH GREASE AND OIL-LUBRICATED BEARINGS

NOTE: DO NOT WRAP OR COVER MOTOR WITH PLASTIC!

1. When to put a motor in storage

If a motor is not put into immediate service (one month or less), or if it is taken out of service for a prolonged period, special storage precautions should be taken to prevent environmental damage. The following schedule is recommended as a guide to determine storage needs.

- Out of service in storage less than one month -- no special precautions except that space heaters, if supplied, must be energized any time the motor is not running.
- Out of service or in storage for more than one month but less than six months -- store per items 2A, B, C, D, E, F2 and G, items 3A, B and C, and item 4.
- Out of service or in storage for six months or more -- all recommendations.

2. Storage preparation

- Where possible, motors should be stored indoors in a clean, dry area.
- When indoor storage is not possible, the motors must be covered with a tarpaulin. This cover should extend to the ground; however, it should not tightly wrap the motor. This will allow the captive air space to breathe, minimizing formation of condensation. Care must also be taken to protect the motor from flooding or from harmful chemical vapors.
- Whether indoors or out, the area of storage should be free from ambient vibration. Excessive vibration can cause bearing damage. A unit which must be stored in areas with high ambient vibration, such as from heavy construction equipment or other sources, must have the shaft locked to prevent any movement. Precautions should be taken to prevent rodents, snakes, birds, or other small animals from nesting inside the motors. In areas where they are prevalent, precautions must be taken to prevent insects, such as mud dauber wasps, from gaining access to the interior of the motor.
- Inspect the rust preventative coating on all external machined surfaces, including shaft extensions. If necessary, recoat the surfaces with a rust preventative material, such as Rusto Veto No. 342 (manufactured by E.F. Houghton Co.) or an equivalent. The condition of the coating should be checked periodically and surfaces recoated as needed.
- Bearings:
 - 1) Grease-lubricated cavities must be completely filled with lubricant during storage. Remove the drain plug and fill cavity with grease until grease begins to purge from the drain opening. Refer to the section on "LUBRICATION" in the U.S. MOTORS® Installation/Maintenance Instruction and/or review motor's lubrication nameplate for correct lubricant.

CAUTION:

DO NOT ATTEMPT TO GREASE BEARINGS WITH DRAIN CLOSED OR WHEN UNIT IS IN OPERATION.



F. LONG-TERM STORAGE FOR MOTORS WITH GREASE AND OIL-LUBRICATED BEARINGS

- 2) Oil-lubricated motors are shipped without oil and must be filled to the maximum capacity as indicated on the oil chamber sight gauge window immediately upon receipt. Fill reservoir to maximum level with a properly selected oil containing rust and corrosion inhibitors such as Texaco Regal Marine #77, Mobil Vaprotec Light, or an equivalent.

NOTE: Motor must not be moved with oil in reservoir. Drain oil before moving to prevent sloshing and possible damage, then refill when at new location.

- To prevent moisture accumulation, some form of heating must be utilized to prevent condensation. This heating should maintain the winding temperature at a minimum of 50°C above ambient. If space heaters are supplied, they should be energized. If none are available, single phase or “trickle” heating may be utilized by energizing one phase of the motor’s winding with a low voltage. Request the required voltage and transformer capacity from Nidec Motor Corporation. A third option is to use an auxiliary heat source and keep the winding warm by either convection or blowing warm air into the motor.

3. Periodic Maintenance

- Oil should be inspected monthly for evidence of moisture or oxidation. The oil must be replaced whenever contamination is noted or every twelve months, whichever occurs first.
- Grease lubricated bearings must be inspected once a month for moisture and oxidation by purging a small quantity of grease through the drain. If any contamination is present, the grease must be completely removed and replaced.
- All motors must have the shaft rotated once a month to insure the maintenance of a coating lubricant film on the bearing races and journals.
- Insulation History:
The only accurate way to evaluate the condition of the winding insulation is to maintain a history of the insulation readings. Over a period of months or years these readings will tend to indicate a trend. If a downward trend develops, or if the resistance drops too low, thoroughly clean and dry the windings, retreating if necessary, by an authorized electrical apparatus service shop.

The recommended insulation resistance tests are as follows:

Two tests are used to evaluate the condition of the winding insulation. The first of these is the one minute insulation resistance test (IR¹) and the second is the polarization index test (PI), which can also be referred to as a dielectric absorption test. The results of either of these tests can be skewed by factors such as the winding temperature and its relation to the dew point temperature at the time the test was conducted. The PI test is less sensitive to these factors than the IR test, but its results can still be affected significantly. Due to these factors, the most reliable method for evaluating the condition of the winding insulation is to maintain a record of periodic measurements, accumulated over months or years of service, for one or both of these tests. It is important that these tests be conducted under similar conditions of winding temperature, dew point temperature, voltage magnitude and duration, and relative humidity. If a downward trend develops in the historical data for either test, or if the readings from both tests drop below a minimum acceptable value, have an authorized electrical apparatus service shop thoroughly clean and dry the winding and re-treat if necessary.





F. LONG-TERM STORAGE FOR MOTORS WITH GREASE AND OIL LUBRICATED BEARINGS

1. The recommended procedure for the IR_1 test is as follows:

- (1) Disconnect all external accessories or equipment that have leads connected to the winding and connect them to a common ground. Connect all other accessories that are in contact with the winding to a common ground.

▲ WARNING
Failure to have accessories grounded during this test can lead to the accumulation of a hazardous charge on the accessories.

- (2) Using a megohmmeter, apply DC voltage at the level noted below for 1 minute and take a reading of the insulation resistance between the motor leads and ground.

<u>Rated Motor Voltage</u>	<u>Recommended DC Test Voltage</u>
UP to 1000 (inclusive)	500 VDC
1001 to 2500 (inclusive)	500 to 1000 VDC
2501 to 5000 (inclusive)	500 to 2500 VDC
5001 and up	500 to 5000 VDC

▲ WARNING
Follow appropriate safety procedures during and after high voltage testing. Refer to the instruction manual for the test equipment. Make sure the winding insulation is discharged before beginning the test. The winding insulation will retain a potentially dangerous charge after the DC voltage source is removed, so use proper procedures to discharge the winding insulation at the end of the test. Refer to IEEE 43 Standard for additional safety information.

- (3) The reading should be corrected to a 40°C base temperature by utilizing the formula:

$$R_{40C} = K_T R_T$$

Where:

R_{40C} = insulation resistance (in megohms) corrected to 40°C

K_T = insulation resistance temperature coefficient at temperature T°C

R_T = measured insulation resistance (in megohms) at temperature T°C

The value of K_T can be approximated by using the formula:

$$K_T = (0.5)^{(40-T)/10}$$

Where:

T = the winding temperature in °C that the insulation resistance was measured at



F. LONG-TERM STORAGE FOR MOTORS WITH GREASE AND OIL LUBRICATED BEARINGS

The recommended procedure for the PI test is as follows:

- (1) Perform steps 1 and 2 from the IR_1 test procedure. Heed the safety warnings given in the IR_1 test procedure.
- (2) With DC voltage still being applied by the megohmmeter, taken an additional reading of insulation resistance between the motor leads and ground 10 minutes after the DC voltage was initially applied. To minimize measurement errors, the variation in winding temperature between the 1 minute and 10 minute readings should be kept to a minimum.
- (3) Obtain the polarization index by taking the ratio of the 10 minute resistance reading to the 1 minute resistance reading.

If historical data from previous IR_1 and / or PI tests is available, then a comparison of the present test result to previous tests can be used to evaluate the condition of the insulation. To minimize error, all readings that are compared should be taken at test voltages, winding temperatures, dew point temperatures, and relative humidity that are similar as possible. If a downward trend in the readings develops over time, have an authorized electrical apparatus service shop thoroughly clean and dry the winding and, if necessary, retreat the winding. Then, repeat the test and re-check results before returning the motor service.

If historical data from previous IR_1 or PI tests is not available, then compare readings from the present test to the recommended minimum values listed below. If the readings from both tests fall below the minimum, have an authorized electrical apparatus service shop thoroughly clean and dry the winding and, if necessary, retreat the winding. Then, repeat the tests and re-check results before returning the motor to service.

The recommended minimum value for the 1 minute insulation resistance reading corrected to 40°C is:

<u>Rated Motor Voltage</u>	<u>Minimum Insulation Resistance</u>
Up to 999 (inclusive)	5 Megohms
1000 and up	100 Megohms

The recommended minimum value for the polarization index is 2.0. If the 1 minute insulation resistance reading corrected to 40° C is above 5000 megohms, however, the polarization index may not be meaningful. In such cases, the polarization index may be disregarded as a measure of insulation condition.

Refer any question to the Nidec Motor Corporation Product Service Department.

For more information, refer to the IEEE^{®†} 43 Standard.

4. Start-up preparations after storage

- Motor should be thoroughly inspected and cleaned to restore to an "As Shipped" condition.
- Motors which have been subjected to vibration must be disassembled and each bearing inspected for damage.
- Oil and/or grease must be completely changed using lubricants and methods recommended on the motor's lubrication plate, or in the section titled "LUBRICATION" in the Installation/Maintenance manual.
- The winding must be tested to obtain insulation resistance and dielectric absorption ratio as described in section III, item 3
- If storage has exceeded one year, the Nidec Motor Corporation Quality Assurance Department must be contacted prior to equipment startup.



QUICK ENGINEERING FACTS



G. TEMPERATURE CLASSIFICATION OF INSULATION SYSTEMS

Insulation System		Temperature Classification	
(1) Class A	Class 105	105°C	221°F
(2) Class E*	Class 120	120°C	248°F
Class B	Class 130	130°C	266°F
Class F	Class 155	155°C	311°F
Class H	Class 180	180°C	356°F
(1) Class N	Class 200	200°C	392°F
(1) Class R	Class 200	220°C	428°F
(1) Class S	Class 240	240°C	464°F
(1) Class C	Class over --240	Over 240°C	Over 464°F

**Used in European equipment
(1) Not an available motor insulation system.*

The temperature classification indicates the maximum (hot-spot) temperature at which the insulation system can be operated for normal expected service life.



INDEX - DIMENSION PRINTS



	Frame	Page
HOLLOSHAFT® Drive Couplings	182-286	E-3
	284-405	E-4
	447-6800	E-5
Single Phase HOLLOSHAFT®	213-256	E-6

Three Phase HOLLOSHAFT®			
Enclosure	Type	Frame	Page
WPI	High Thrust	182-286	E-7
WPI	High Thrust	324-H445	E-8
WPI	High Thrust	447	E-9
WPI	High Thrust	449	E-10
WP II	High Thrust	449	E-11
WPI	High Thrust	5008-5012	E-12
WP II	High Thrust	5008-5012	E-13
WPI	High Thrust	5813	E-14
WP II	High Thrust	5813	E-15
WPI	High Thrust	6808-6810	E-16
WP II	High Thrust	6808-6810	E-17
WPI	High Thrust	6813	E-18
WP II	High Thrust	6813	E-19
WPI	High Thrust	8006-8011	E-20
WP II	High Thrust	8006-8011	E-21
WPI	High Thrust	9601-9608	E-22
WP II	High Thrust	9601-9608	E-23
TEFC	High Thrust	182-286	E-24
TEFC	High Thrust	324-447	E-25
TEFC	High Thrust	449	E-26
TEFC	High Thrust	182-286	E-27
TEFC	High Thrust	324-447	E-28
TEFC/ Hazardous Location	High Thrust	5008	E-29
TEFC/ Hazardous Location	High Thrust	5800	E-30
TEFC	High Thrust	5812	E-31
TEFC	High Thrust	6812	E-32

Three Phase Solid Shaft			
Enclosure	Type	Frame	Page
WPI	Normal Thrust HP	182-286	E-33
WPI	Normal Thrust VP	182-286	E-34



INDEX - DIMENSION PRINTS



Three Phase Solid Shaft (continued)

Enclosure	Type	Frame	Page
WPI	Normal Thrust HP	324-445	E-35
WPI	Normal Thrust VP	324-445	E-36
WPI	Normal Thrust HP	447	E-37
WPI	Normal Thrust VP	447	E-38
WPI	Normal Thrust P Base	5008 - 5012	E-39
WPI	Normal Thrust P Base	6808-6810	E-40
WPI	Normal Thrust P Base	6813	E-41
WPI	Normal Thrust P Base	8000	E-42
WPI	High Thrust P Base	182-286	E-43
WPI	High Thrust P Base	324-445	E-44
WPI	High Thrust P Base	447	E-45
WPI	High Thrust P Base	449	E-46
WPII	High Thrust P Base	449	E-47
WPI	High Thrust P Base	5000	E-48
WPII	High Thrust P Base	5000	E-49
WPI	Normal Thrust P Base	5813	E-50
WPII	Normal Thrust P Base	5813	E-51
WPI	High Thrust P Base	6808-6810	E-52
WPII	High Thrust P Base	6808-6810	E-53
WPI	High Thrust P Base	6813	E-54
WPII	High Thrust P Base	6813	E-55
WPI	High Thrust P Base	8006-8011	E-56
WPII	High Thrust P Base	8006-8011	E-57
WPI	High Thrust P Base	9600	E-58 E-60
WPII	High Thrust P Base	9600	E-61 E-62
TEFC	Normal Thrust C-Face	140-440	E-63 E-64
TEFC	Normal Thrust HP & VP	143-286	E-65 E-66
TEFC	Normal Thrust HP & VP	324-447	E-67 E-68
Hazardous Location	Normal Thrust HP & VP	143-286	E-69
Hazardous Location	Normal Thrust HP & VP	324-447	E-70
TEFC	High Thrust P Base	182-286	E-71
TEFC	High Thrust P Base	324-447	E-72
Hazardous Location	High Thrust P Base	182-286	E-73
Hazardous Location	High Thrust P Base	324-447	E-74
TEFC	Medium Thrust P Base	182-286	E-75
TEFC	Medium Thrust P Base	324-447	E-76
Hazardous Location	Medium Thrust P Base	182-286	E-77
Hazardous Location	Medium Thrust P Base	324-447	E-78
TEFC	Normal/Medium P Base	449	E-79
Hazardous Location	Normal Thrust P Base	5008	E-80
TEFC	High Thrust P Base	449	E-81
Hazardous Location	High Thrust P Base	5008	E-82
TEFC/ Hazardous Location	High Thrust P Base	5800	E-83
TEFC	High Thrust	5812	E-84
TEFC	High Thrust	6812	E-85



DIMENSIONS
HOLLOSHAFT®
DRIVE COUPLING PART NUMBERS

COUPLINGS
182-286
FRAMES

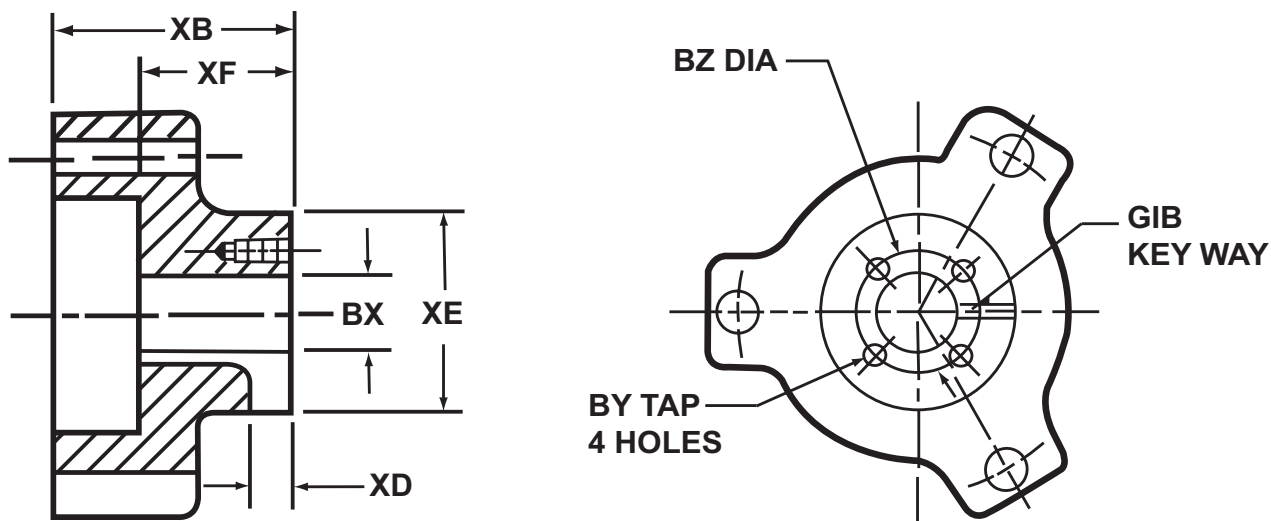

Frame	Type	Part Number	Bore Size		Key	BY	BZ	XB	XD	XE	XF
			Nominal	Actual							
182 - 215	AU, AUR TU, LU	159002	0.750	0.751	0.188	10-32	1.375	1.750	0.344	2.000	1.125
		181107	0.875	0.876	0.188	10-32	1.375	1.750	0.406	2.000	1.125
		159001	1.000	1.001	0.250	10-32	1.375	1.750	0.406	2.000	1.125
		157744	BLANK	0.624	---	---	---	1.750	---	2.000	1.125
254 - 256	AU, AUC TU, LU	174431	0.750	0.751	0.188	10-32	1.375	2.563	0.344	2.250	1.625
		181105	0.875	0.876	0.188	10-32	1.375	2.563	0.344	2.250	1.625
		B 102999	1.000	1.001	0.250	10-32	1.375	2.563	0.406	2.250	1.625
		779353*	1.063	1.063	0.250	10-32	1.375	2.563	0.406	2.250	1.625
		B 104720	1.188	1.188	0.250	.25-20	1.750	2.563	0.406	2.250	1.625
		152434	1.250	1.251	0.250	.25-20	1.750	2.563	0.406	2.250	1.625
		366983	1.250	1.251	0.375	.25-20	1.750	2.563	0.531	2.250	1.625
		B 102986	BLANK	0.751	---	---	---	2.563	-	2.250	1.625
284 - 286	AU, TU	174431	0.750	0.751	0.188	10-32	1.375	2.563	0.344	2.250	1.625
		181105	0.875	0.876	0.188	10-32	1.375	2.563	0.344	2.250	1.625
		B 102999	1.000	1.001	0.250	10-32	1.375	2.563	0.406	2.250	1.625
		779353*	1.063	1.063	0.250	10-32	1.375	2.563	0.406	2.250	1.625
		B 104720	1.188	1.188	0.250	.25-20	1.750	2.563	0.406	2.250	1.625
		152434	1.250	1.251	0.250	.25-20	1.750	2.563	0.406	2.250	1.625
		366983	1.250	1.251	0.375	.25-20	1.750	2.563	0.531	2.250	1.625
		B 102986	BLANK	0.751	---	---	---	2.563	---	2.250	1.625

*Product listed may not be available from stock.



**DIMENSIONS
HOLLOSHAFT®
DRIVE COUPLING PART NUMBERS**

**COUPLINGS
284 - 405
FRAMES**

Frame	Type	Part Number	Bore Size		Key	BY	BZ	XB	XD	XE	XF
			Nominal	Actual							
284 - 286	LU	922477*	.750	.751	.188	10-32	1.375	2.563	.406	2.625	1.625
		181104	.875	.876	.188	10-32	1.375	2.563	.406	2.625	1.625
		A112000	1.000	1.001	.250	10-32	1.375	2.563	.406	2.625	1.625
		A108186	1.188	1.188	.250	25-20	1.750	2.563	.406	2.625	1.625
		922970*	1.313	1.313	.250	25-20	1.750	2.563	.406	2.625	1.625
		162457	1.250	1.251	.250	25-20	1.750	2.563	.406	2.625	1.625
		366982	1.250	1.250	.375	25-20	1.750	2.563	.531	2.625	1.625
		661737*	1.500	1.501	.250	25-20	2.125	2.563	.406	2.625	1.625
B108184	BLANK	.751	---	---	---	2.563	---	2.625	1.625		
324 - 326	RU, TU, LU	136731	1.000	1.001	0.250	10-32	1.375	2.938	0.406	2.875	1.938
		132607	1.188	1.188	0.250	25-20	1.750	2.938	0.406	2.875	1.938
		162458	1.250	1.251	0.250	25-20	1.750	2.938	0.406	2.875	1.938
		132608	1.250	1.251	0.375	25-20	1.750	2.938	0.531	2.875	1.938
		795905*	1.313	1.313	0.375	25-20	1.750	2.938	0.531	2.875	1.938
		132609	1.438	1.438	0.375	25-20	2.125	2.938	0.531	2.875	1.938
		132610	1.500	1.501	0.375	25-20	2.125	2.938	0.531	2.875	1.938
		B 108565	BLANK	0.751	---	---	---	2.938	---	2.875	1.938
364 - 365	TU, LU	471208*	1.000	1.001	0.250	25-20	1.375	3.813	0.406	3.875	2.750
		172313	1.188	1.188	0.250	25-20	1.750	3.813	0.406	3.875	2.750
		172315	1.250	1.251	0.250	25-20	1.750	3.813	0.406	3.875	2.750
		366985	1.250	1.251	0.375	25-20	1.750	3.813	0.531	3.875	2.750
		172314	1.438	1.438	0.375	25-20	2.125	3.813	0.531	3.875	2.750
		118296	1.500	1.501	0.375	25-20	2.125	3.813	0.531	3.875	2.750
		929360*	1.563	1.563	0.375	25-20	2.125	3.813	0.531	3.875	2.750
		789957*	1.625	1.626	0.375	25-20	2.125	3.813	0.531	3.875	2.750
		118297*	1.688	1.688	0.375	25-20	2.500	3.813	0.531	3.875	2.750
		118298*	1.750	1.751	0.375	25-20	2.125	3.813	0.531	3.875	2.750
		118295	BLANK	0.751	---	---	---	3.813	---	3.875	2.750
364 - 365	RU	136731	1.000	1.001	0.250	10-32	1.375	2.938	0.406	2.875	1.938
		132607	1.188	1.188	0.250	25-20	1.750	2.938	0.406	2.875	1.938
		162458	1.250	1.251	0.250	25-20	1.750	2.938	0.406	2.875	1.938
		132608	1.250	1.251	0.375	25-20	1.750	2.938	0.531	2.875	1.938
		795905*	1.313	1.313	0.375	25-20	1.750	2.938	0.531	2.875	1.938
		132609	1.438	1.438	0.375	25-20	2.125	2.938	0.531	2.875	1.938
		132610	1.500	1.501	0.375	25-20	2.125	2.938	0.531	2.875	1.938
		B 108565	BLANK	0.751	---	---	---	2.938	---	2.875	1.938
404 - 405	TU, LU	471208*	1.000	1.001	0.250	25-20	1.375	3.813	0.406	3.875	2.750
		172313	1.188	1.188	0.250	25-20	1.750	3.813	0.406	3.875	2.750
		172315	1.250	1.251	0.250	25-20	1.750	3.813	0.406	3.875	2.750
		366985	1.250	1.251	0.375	25-20	1.750	3.813	0.531	3.875	2.750
		172314	1.438	1.438	0.375	25-20	2.125	3.813	0.531	3.875	2.750
		118296	1.500	1.501	0.375	25-20	2.125	3.813	0.531	3.875	2.750
		929360*	1.563	1.563	0.375	25-20	2.125	3.813	0.531	3.875	2.750
		789957*	1.625	1.626	0.375	25-20	2.125	3.813	0.531	3.875	2.750
		118297	1.688	1.688	0.375	25-20	2.500	3.813	0.531	3.875	2.750
		118298*	1.750	1.751	0.375	25-20	2.500	3.813	0.531	3.875	2.750
		926393*	1.875	1.876	0.500	25-20	2.500	3.813	0.531	3.875	2.750
118299*	1.938	1.938	0.500	25-20	2.500	3.813	0.531	3.875	2.750		
404 - 405	RU	133000	1.188	1.188	0.250	25-20	1.750	3.406	0.406	3.125	2.406
		707806*	1.250	1.251	0.250	25-20	1.750	3.406	0.406	3.125	2.406
		661856	1.250	1.251	0.375	25-20	1.750	3.406	0.531	3.125	2.406
		133002	1.438	1.438	0.375	25-20	2.125	3.406	0.531	3.125	2.406
		133003	1.500	1.501	0.375	25-20	2.125	3.406	0.531	3.125	2.406
		766777*	1.563	1.563	0.375	25-20	2.500	3.406	0.531	3.125	2.406
		149451	1.688	1.688	0.375	25-20	2.500	3.406	0.531	3.125	2.406
		928124*	1.813	1.813	0.375	25-20	2.500	3.406	0.531	3.125	2.406
		133005	BLANK	0.751	---	---	---	3.406	---	3.125	2.406

*Product listed may not be available from stock.



† All marks shown within this document are properties of their respective owners.

**DIMENSIONS
HOLLOSHAFT®
DRIVE COUPLING PART NUMBERS**

**COUPLINGS
447 - 6800
FRAMES**

Frame	Type	Part Number	Bore Size		Key	BY	BZ	XB	XD	XE	XF		
			Nominal	Actual									
444 - 447	TU, LU	172313	1.188	1.188	0.250	.25-20	1.750	3.813	0.406	3.875	2.750		
		172315	1.250	1.251	0.250	.25-20	1.750	3.813	0.406	3.875	2.750		
		172314	1.438	1.438	0.375	.25-20	2.125	3.813	0.531	3.875	2.750		
		118296	1.500	1.501	0.375	.25-20	2.125	3.813	0.531	3.875	2.750		
		929360*	1.563	1.563	0.375	.25-20	2.125	3.813	0.531	3.875	2.750		
		789957*	1.625	1.626	0.375	.25-20	2.125	3.813	0.531	3.875	2.750		
		118297	1.688	1.688	0.375	.25-20	2.500	3.813	0.531	3.875	2.750		
		118298	1.750	1.751	0.375	.25-20	2.500	3.813	0.531	3.875	2.750		
		926393*	1.875	1.876	0.500	.25-20	2.500	3.813	0.531	3.875	2.750		
		118299	1.938	1.938	0.500	.25-20	2.500	3.813	0.531	3.875	2.750		
H444 - 447	RU	945496*	1.313	1.313	0.375	.25-20	2.125	4.000	0.688	3.688	2.875		
		132576	1.438	1.438	0.375	.25-20	2.125	4.000	0.688	3.688	2.875		
		132577	1.500	1.501	0.375	.25-20	2.125	4.000	0.531	3.688	2.875		
		132578	1.688	1.688	0.375	.25-20	2.500	4.000	0.531	3.688	2.875		
		742204*	1.750	1.751	0.375	.25-20	2.500	4.000	0.531	3.688	2.875		
		132579	1.938	1.938	0.500	.25-20	2.500	4.000	0.688	3.688	2.875		
		934083*	2.125	2.126	0.500	.375-16	3.250	4.000	0.688	4.000	2.875		
		136874	2.188	2.188	0.500	.375-16	3.250	4.000	0.688	4.000	2.875		
		136875	2.250	2.251	0.500	.375-16	3.250	4.000	0.688	4.000	2.875		
		131805	BLANK	0.751	---	---	---	4.000	---	3.688	2.875		
5008	RU	129679	1.688	1.688	0.375	.25-20	2.500	4.375	0.531	4.750	3.063		
		A 113288	1.938	1.938	0.500	.25-20	2.500	4.375	0.688	4.750	3.063		
		A 113287	2.125	2.126	0.500	.375-16	3.250	4.375	0.688	4.750	3.063		
		A 113289	2.188	2.188	0.500	.375-16	3.250	4.375	0.688	4.750	3.063		
449	JU, HU	863877	2.250	2.251	0.500	.375-16	3.250	4.375	0.688	4.750	3.063		
		A 113313	2.375	2.376	0.625	.375-16	3.250	4.375	0.781	4.750	3.063		
5008	EU	A113290	2.438	2.438	0.625	.375-16	3.250	4.375	0.781	4.750	3.063		
		A 113314	2.500	2.501	0.625	.375-16	3.750	4.375	0.781	4.750	3.063		
		A 113285	BLANK	---	---	---	---	4.375	---	4.750	3.063		
5012+	RU	803186	1.688	1.688	0.375	.25-20	2.500	5.125	0.500	5.000	3.625		
		235069	1.938	1.938	0.500	.25-20	2.500	5.125	0.500	5.000	3.625		
		248380	2.125	2.126	0.625	.375-16	3.250	5.125	0.500	5.000	3.625		
		143112	2.188	2.188	0.500	.375-16	3.250	5.125	0.500	5.000	3.625		
		238062	2.250	2.251	0.500	.375-16	3.250	5.125	0.500	5.000	3.625		
		A143113	2.438	2.438	0.625	.375-16	3.250	5.125	0.500	5.000	3.625		
		249156	2.500	2.501	0.625	.375-16	3.250	5.125	0.500	5.000	3.625		
5800	JU, EU	143115	2.688	2.688	0.625	.375-16	3.750	5.125	0.500	5.000	3.625		
		143116	2.750	2.751	0.625	.375-16	3.250	5.125	0.500	5.000	3.625		
		143111	BLANK	BLANK	BLANK	---	---	5.125	---	5.000	3.625		
		791724	2.188	2.188	0.500	.375-16	3.250	7.875	0.565	7.625	6.000		
		X784790	2.438	2.438	0.625	.375-16	3.250	7.875	0.781	7.625	6.000		
5813	RU	293643	2.688	2.688	0.625	.375-16	3.250	7.875	0.688	7.625	6.000		
		973653	2.750	2.751	0.625	.375-16	3.750	7.875	0.813	7.625	6.000		
		830210	2.938	2.938	0.750	.375-16	3.750	7.875	1.000	7.625	6.000		
		255753	3.188	3.188	0.875	.375-16	5.000	7.875	1.000	7.625	6.000		
		255609	3.438	3.438	0.875	.375-16	5.000	7.875	1.000	7.625	6.000		
		178609	3.875	3.876	0.875	.500-13	5.000	7.875	1.000	7.625	6.000		
		178611	BLANK	BLANK	---	---	---	7.875	---	7.625	6.000		
		6800	HU	791724	2.188	2.188	0.500	.375-16	3.250	7.875	0.565	7.625	6.000
				X784790	2.438	2.438	0.625	.375-16	3.250	7.875	0.781	7.625	6.000
				293643	2.688	2.688	0.625	.375-16	3.250	7.875	0.688	7.625	6.000
973653	2.750			2.751	0.625	.375-16	3.750	7.875	0.813	7.625	6.000		
830210	2.938			2.938	0.750	.375-16	3.750	7.875	1.000	7.625	6.000		
255753	3.188			3.188	0.875	.375-16	5.000	7.875	1.000	7.625	6.000		
255609	3.438			3.438	0.875	.375-16	5.000	7.875	1.000	7.625	6.000		
178609	3.875			3.876	0.875	.500-13	5.000	7.875	1.000	7.625	6.000		
178611	BLANK			BLANK	---	---	---	7.875	---	7.625	6.000		

+5012 Oil - Oil design has max bore diameter of 2.5"



† All marks shown within this document are properties of their respective owners.

DIMENSIONS
WEATHER PROTECTED I
HOLLOSHAFT®
FRAME: 213P - 256 UPH

TYPES: AUC & AUR

PRINTS
213-256
AUC, AUR

Typical Dimensions For Reference Only

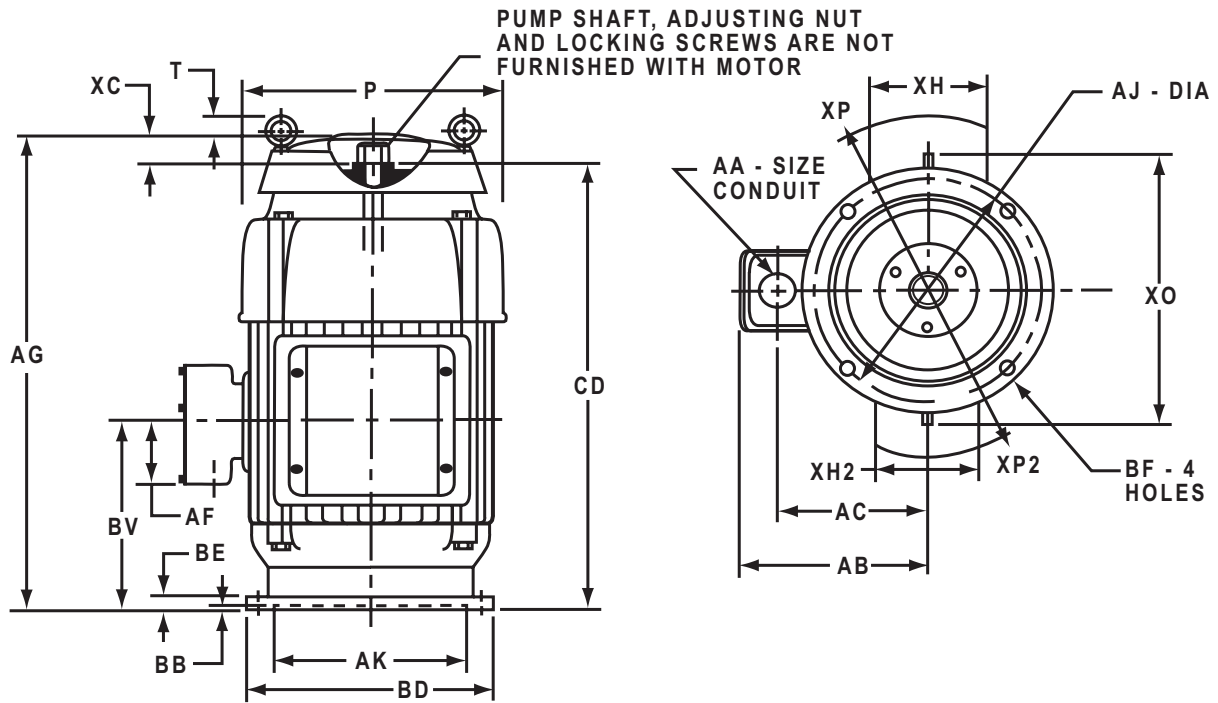

ALL DIMENSIONS ARE IN INCHES

BASIC FRAME	P ²	T	AG	AJ	AK +.003	BB	BE	BF	BV	CD	XC	XO
210	12.875	1.5	21.25	9.125	8.25	0.187	0.75	0.437	8	17.562	3.343	---
250	14	---	26.75	9.125	8.25	0.25	0.937	0.437	11.5	24.75	3.218	16.875

FRAME	TYPE	AA	AB	AC	AF	BD	XH	XH2	XP	XP2
215P (5HP, 2 POLE)	AUR	.75 NPT	7.94	6.94	3.06	10	6.125	6.125	8.75	7.75
213P, 215P	AUR	.75 NPT	7.94	6.94	3.06	10	6.125	---	7.75	---
254UP, 256UP	AUC	1.25 NPT	8.937	7.75	3.593	10	7.5	7.5	10.562	9.687
254UPH, 256UPH	AUC	1.25 NPT	8.937	7.75	3.593	12	7.5	7.5	10.562	9.687

- 1: ALL ROUGH CASTING DIMENSIONS MAY VARY BY 1/4" DUE TO CASTING VARIATIONS.
- 2: LARGEST MOTOR WIDTH.
- 3: CONDUIT BOX MAY BE LOCATED IN STEPS OF 90° STANDARD AS SHOWN WITH CONDUIT OPENING DOWN.

TOLERANCES	
FACE RUNOUT	.004 T.I.R.
PERMISSIBLE ECCENTRICITY OF MOUNTING RABBET	.004 T.I.R.



DIMENSIONS
WEATHER PROTECTED I
HOLLOSHAFT®
FRAME: 182TP - 286TPH

TYPES: AU, AUE & AUI

PRINTS
182-286
AU, AUE,
AUI

Typical Dimensions For Reference Only

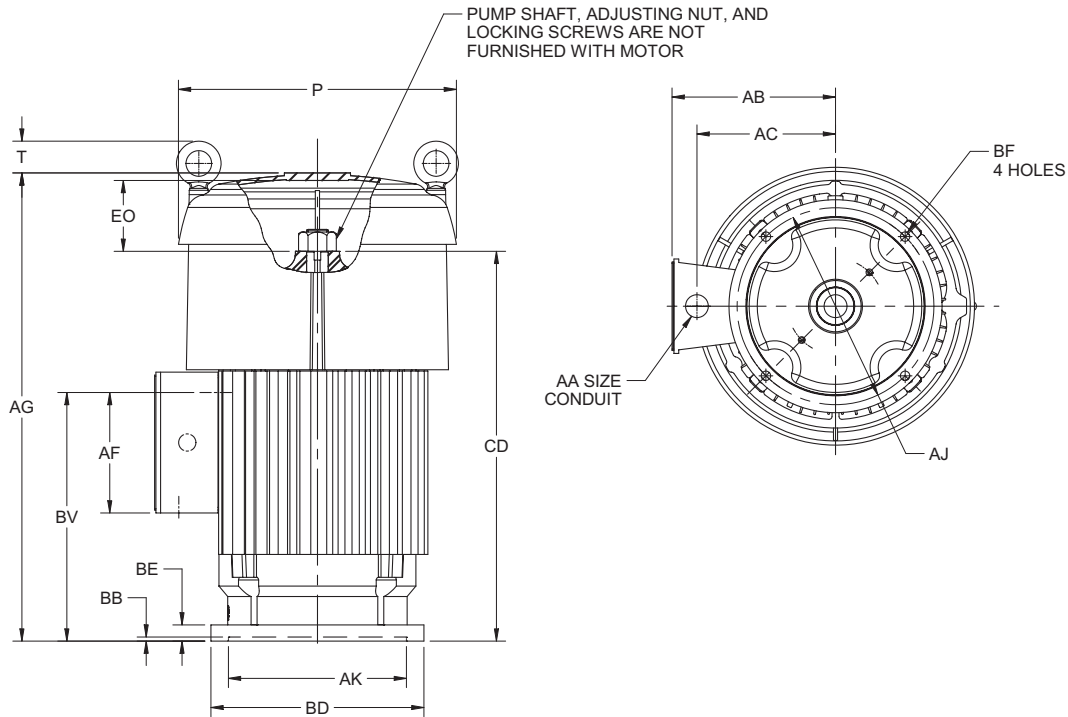

ALL DIMENSIONS ARE IN INCHES

BASIC FRAME	P ²	AA	AB	AC	AF	AG	BE	BV	CD	XC	XO
180 [®]	12.875	1.5	1	7.30	6.14	2.625	21.25	8	17.562	3.343	---
210	12.875	1.5	1	7.88	6.63	3.19	21.25	8	17.562	3.343	---
250	14	---	1.25	10.25	7.88	2.03	26.75 [®]	11.5	23.375 [®]	3.218	16.875
280	14	---	1.5	11.07	8.32	2.59	28.13	12.25	24.75	3.218	16.875

FRAME	AJ	AK	BB	BD	BE	BF
182, 184, 213, 215TP	9.125	8.250	0.187	10	0.75	0.437
254, 256, 284, 286TP	9.125	8.250	0.25	10	0.937	0.437
254,256TPA, 284, 286TPA	14.75	13.500	0.25	16.5	0.937	0.687
254, 256TPH, 284, 286TPH	9.125	8.250	0.25	12	0.937	0.437

TOLERANCES	8.25 AK	13.5 AK
FACE RUNOUT	.004 T.I.R.	.007 T.I.R.
PERMISSIBLE ECCENTRICITY OF MOUNTING RABBET	.004 T.I.R.	.007 T.I.R.
FACE RUNOUT	-.000, +.003	-.000, +.005

1. ALL ROUGH DIMENSIONS MAY VARY BY .25" DUE TO CASTING AND/OR FABRICATION VARIATIONS.
 2. LARGEST MOTOR WIDTH.
 3. CONDUIT BOX MAY BE LOCATED IN STEPS OF 90 DEGREES AS SHOWN WITH CONDUIT OPENING DOWN.
- © FRAMES 182TP ARE TYPE AU ONLY.
 © DIMENSIONS SHOWN ARE FOR ALL RATINGS EXCEPT 20 HP, 4 POLE, TYPE AUE.
 FOR THIS RATING THE DIMENSIONS ARE: AG = 28-1/8, CD = 24-3/4.



† All marks shown within this document are properties of their respective owners.

DIMENSIONS
WEATHER PROTECTED I
HOLLOSHAFT®

FRAME: 324P - H445TPA

TYPES: RU, RUE, RUI & RUS

PRINTS
324-445
RU, RUE,
RUI, RUS

Typical Dimensions For Reference Only

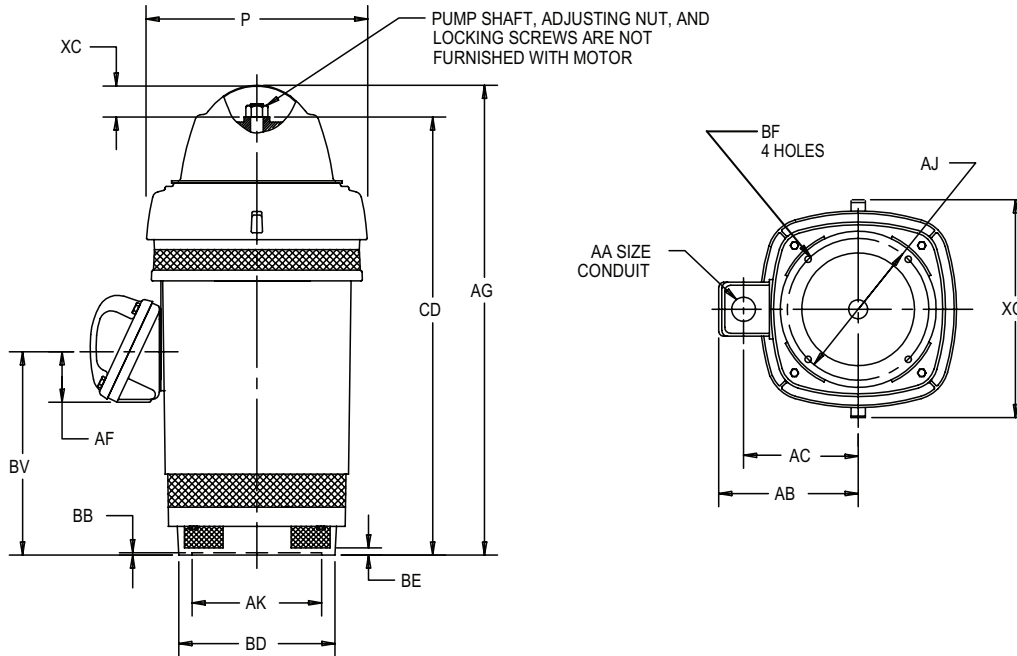

ALL DIMENSIONS ARE IN INCHES

BASIC FRAME	P ²	AA	AB	AC	AF	AG	BE	BV	CD	XC	XO
320	19.06	3	15.187	11.625	4	33.06	0.687	11.062	28.218	4.218	21.69
360	19.06	3	15.187	11.625	4	36	.69	14	31.156	4.218	21.69
400	23.75	3	16.375	12.75	4	42.69	0.75	18.125	36.937	4.562	24.13
H440	23.38	3	18.94	14.44	4.72	50.06	.75	21.16	44.78	5.13	27.50

FRAME	AJ	AK	BB	BD MAX	BF
324, 326TP	14.75	13.5	0.25	16.5	0.687
324, 326TPH	9.125	8.25	0.187	12	0.437
364, 365TP	14.75	13.5	0.25	16.5	0.687
364, 365TPA	9.125	8.25	0.187	12	0.437
404, 405TP	14.75	13.5	0.25	16.5	0.687
404, 405TPA	14.75	13.5	0.25	20	0.687
444, 445TP	14.75	13.5	0.25	16.5	0.687
H444, H445TPA	14.75	13.5	0.25	20	0.687

TOLERANCES	8.25 AK	13.50 AK
"AK" DIMENSION	+.003; -.000	+.005; -.000
FACE RUNOUT	.004 T.I.R.	.007 T.I.R.
PERMISSIBLE ECCENTRICITY OF MOUNTING RABBET	.004 T.I.R.	.007 T.I.R.

- 1: ALL ROUGH CASTING DIMENSIONS MAY VARY BY .25" DUE TO CASTING VARIATIONS.
- 2: LARGEST MOTOR WIDTH.
- 3: CONDUIT OPENING MAY BE LOCATED IN STEPS OF 90°. STANDARD AS SHOWN WITH CONDUIT OPENING DOWN.



† All marks shown within this document are properties of their respective owners.

DIMENSIONS

WEATHER PROTECTED I
HOLLOSHAFT®

FRAME: 447TP, TPA, TPB

TYPES: RU & RUS

PRINTS
447
RU, RUS

Typical Dimensions For Reference Only

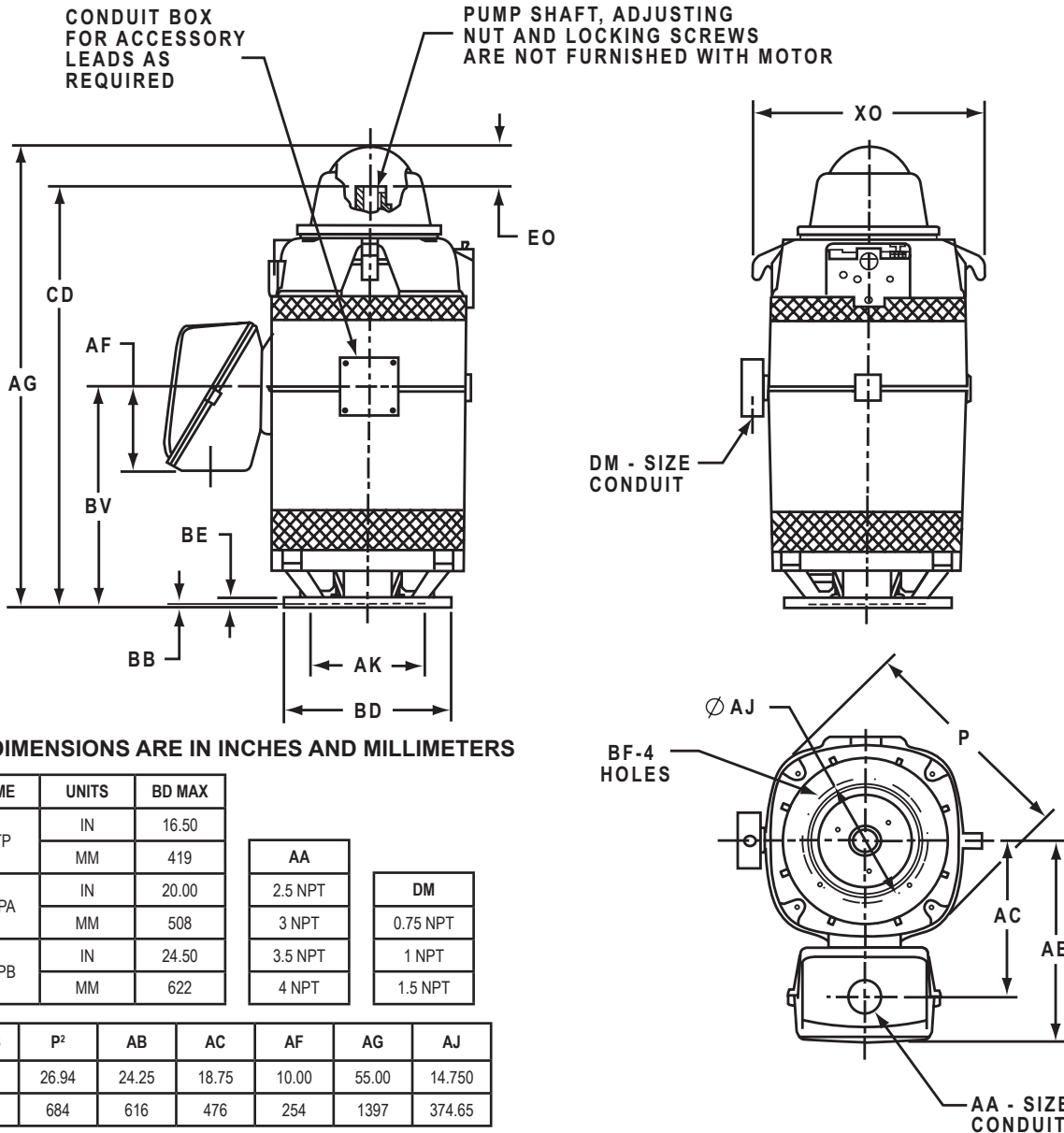

ALL DIMENSIONS ARE IN INCHES AND MILLIMETERS

FRAME	UNITS	BD MAX
447TP	IN	16.50
	MM	419
447TPA	IN	20.00
	MM	508
447TPB	IN	24.50
	MM	622

AA	DM
2.5 NPT	0.75 NPT
3 NPT	1 NPT
3.5 NPT	1.5 NPT
4 NPT	

UNITS	P ²	AB	AC	AF	AG	AJ
IN	26.94	24.25	18.75	10.00	55.00	14.750
MM	684	616	476	254	1397	374.65

UNITS	AK +.005	BB MIN	BE	BF	BV	CD	EO	XO
IN	13.500	.25	1.00	.69	26.19	49.78	5.13	27.50
MM	342.90	6	25	18	665	1264	130	699

- 1: DIMENSIONS MAY VARY BY .25" DUE TO CASTING AND/OR FABRICATION VARIATIONS.
- 2: LARGEST MOTOR WIDTH.
3. TOLERANCES SHOWN ARE IN INCHES ONLY.



† All marks shown within this document are properties of their respective owners.

DIMENSIONS
WEATHER PROTECTED I
HOLLOSHAFT®
FRAME: 449TPH, TP, TPA

TYPES: RU & RUS

PRINTS
449
RU, RUS

Typical Dimensions For Reference Only

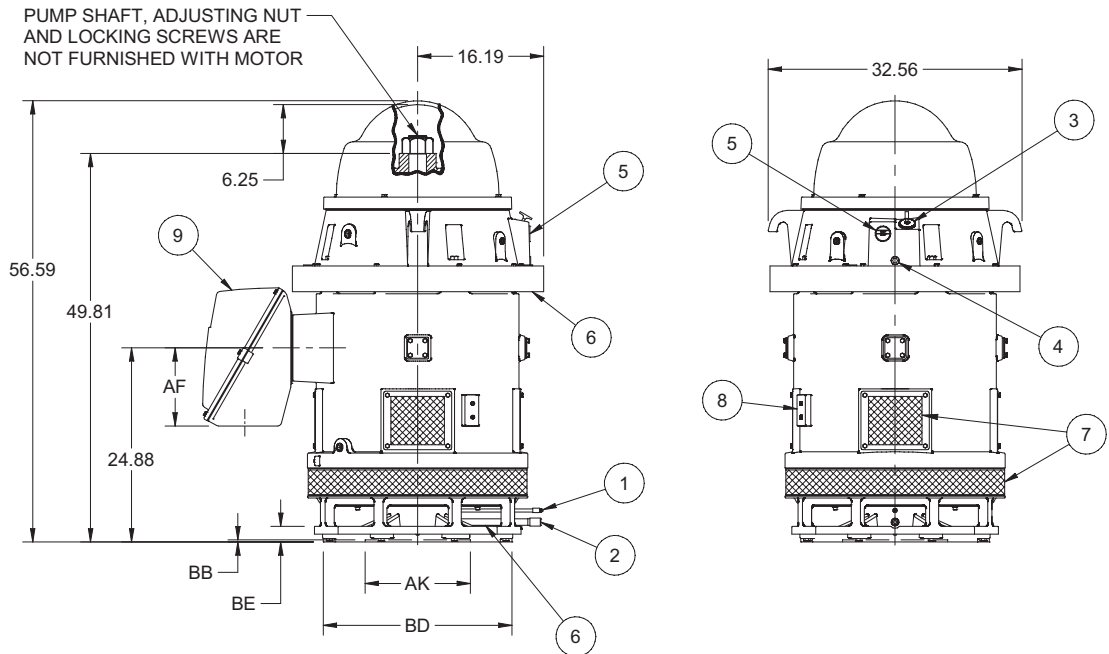

ALL DIMENSIONS ARE IN INCHES

C/BOX VOLUME (CU. IN.)	QTY OF CONDUIT HOLES	AB	AC	AD	AF
2000	1	27.63	22.13	--	10.00
3400	2	33.28	24.25	3.00	10.94

FRAME	AJ	AK +.005	BB MIN	BD MAX	BE	BF
449TPH	14.75	13.500	.25	20.00	2.00	.688
449TP	14.75	13.500		24.50		.938
	22.00			30.50		.813
449TPA	32.00	22.000				

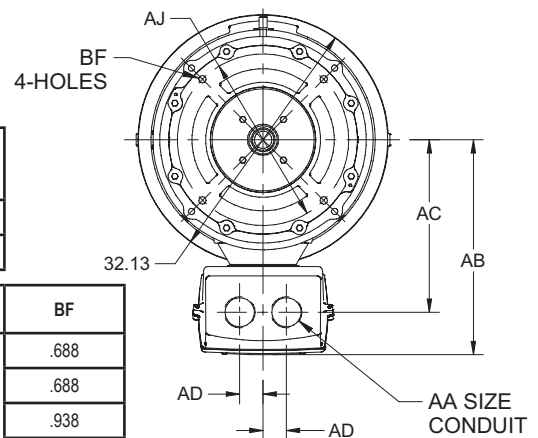

FEATURE LISTING

1	LOWER GREASE FILL	6	AIR INTAKE, 360° AROUND
2	LOWER GREASE DRAIN	7	AIR EXHAUST, 360° AROUND
3	UPPER SUMP OIL FILL	8	GRD PADS, DIAG OPP, 1/2-13
4	UPPER SUMP OIL DRAIN	9	MAIN CONDUIT BOX
5	UPPER SUMP SIGHT WINDOW	10	449P HAS TWO BOLT CIRCLES

- 1: ALL ROUGH CASTING DIMENSIONS MAY VARY BY .25" DUE TO CASTING VARIATIONS.
 2: LARGEST MOTOR WIDTH.
 3: CONDUIT OPENING MAY BE LOCATED IN STEPS OF 900.
 STANDARD AS SHOWN WITH CONDUIT OPENING DOWN.

TOLERANCES	
FACE RUNOUT	.007 T.I.R.
PERMISSIBLE ECCENTRICITY OF MOUNTING RABBET	.007 T.I.R.
NON-MACHINED DIMENSIONS MAY VARY BY ±.25	



DIMENSIONS
WEATHER PROTECTED II
HOLLOSHAFT®
FRAME: 449TPH, TP, TPA

TYPES: RU & RUS

PRINTS
449
RU

Typical Dimensions For Reference Only

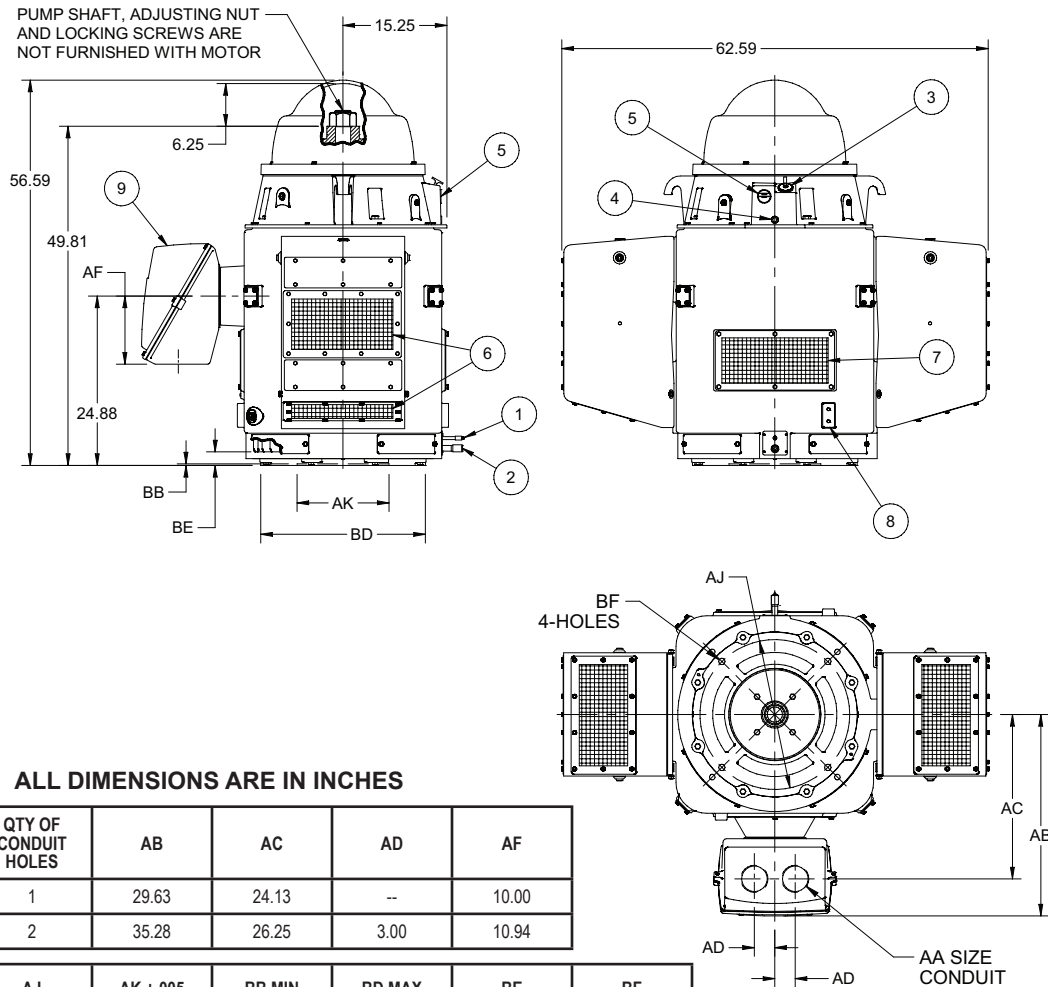

ALL DIMENSIONS ARE IN INCHES

C/BOX VOLUME (CU. IN.)	QTY OF CONDUIT HOLES	AB	AC	AD	AF
2000	1	29.63	24.13	--	10.00
3400	2	35.28	26.25	3.00	10.94

FRAME	AJ	AK +.005	BB MIN	BD MAX	BE	BF
449TPH	14.75	13.500	.25	20.00	2.00	.688
449TP	14.75	13.500		24.50		.938
	22.00			30.50		.813
449TPA	32.00	22.000				

FEATURE LISTING

1	LOWER GREASE FILL	6	AIR INTAKE, 360° AROUND
2	LOWER GREASE DRAIN	7	AIR EXHAUST, 360° AROUND
3	UPPER SUMP OIL FILL	8	GRD PADS, DIAG OPP, 1/2-13
4	UPPER SUMP OIL DRAIN	9	MAIN CONDUIT BOX
5	UPPER SUMP SIGHT WINDOW	10	449P HAS TWO BOLT CIRCLES

- 1: ALL ROUGH CASTING DIMENSIONS MAY VARY BY .25" DUE TO CASTING VARIATIONS.
- 2: LARGEST MOTOR WIDTH.
- 3: CONDUIT OPENING MAY BE LOCATED IN STEPS OF 90°. STANDARD AS SHOWN WITH CONDUIT OPENING DOWN.

TOLERANCES	
FACE RUNOUT	.007 T.I.R.
PERMISSIBLE ECCENTRICITY OF MOUNTING RABBET	.007 T.I.R.
NON-MACHINED DIMENSIONS MAY VARY BY ±.25	



DIMENSIONS

WEATHER PROTECTED I

HOLLOSHAFT®

FRAME: 5008-5012PH, P, PA

TYPES: RU & RUE

PRINTS
5008-5012
RU, RUE

Typical Dimensions For Reference Only

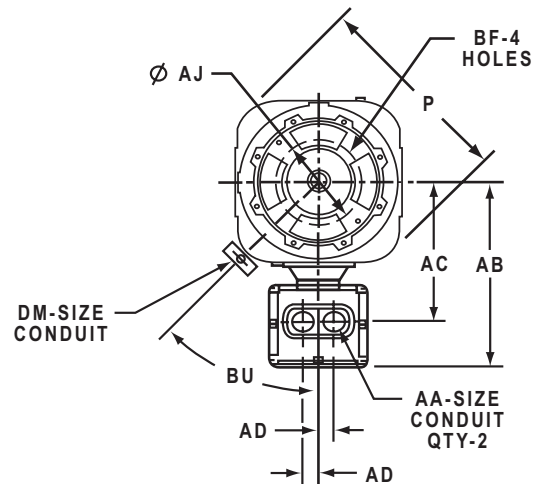
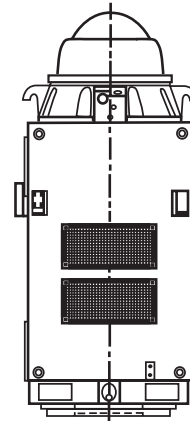
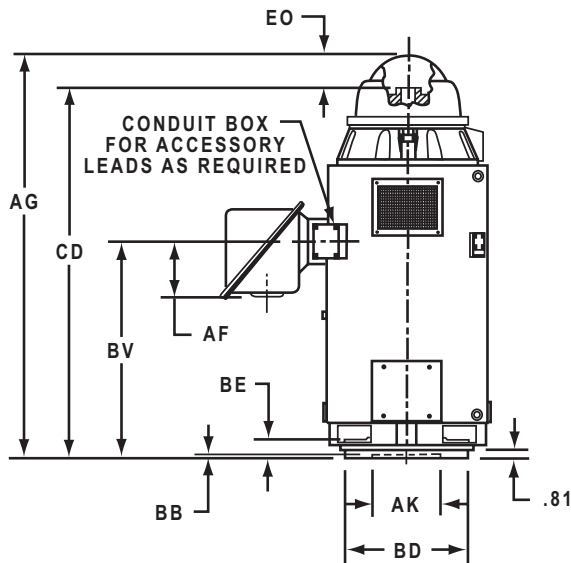

ALL DIMENSIONS ARE IN INCHES

TOLERANCES	
FACE RUNOUT	.007 T.I.R.
PERMISSIBLE ECCENTRICITY OF MOUNTING RABBET	.007 T.I.R.
MAXIMUM SHAFT END PLAY	.010

AA	DM
2 NPT	0.5 NPT
2.5 NPT	0.75 NPT
3 NPT	1 NPT
3.5 NPT	1.25 NPT
4 NPT	1.5 NPT

FRAME	P	AG	BV	CD	EO
5008	40.00	63.88	27.00	57.06	6.42
5012		78.88	42.00	72.30	

FRAME	AJ	AK +.005	BB MIN	BD MAX	BE	BF
5000PH	14.750	13.500	.25	20.00	2.19	.69
5000P ³	14.750	13.500		24.50		.69
	22.000			.94		
5000PA	26.000	22.000	30.50	.81		

VOLTS	C/BOX VOLUME (CU. IN.)	AB	AC	AD	AF	BU
0-4800	3400	36.50	27.88	3.00	10.94	45°
4801-6900	5600	36.13	30.13	4.00	10.81	

1: DIMENSIONS MAY VARY .25" DUE TO CASTING AND/OR FABRICATION VARIATIONS.
2: DIMENSIONS AND TOLERANCES ARE SHOWN IN INCHES.
3: 5000P HAS TWO BOLT CIRCLES.



† All marks shown within this document are properties of their respective owners.

DIMENSIONS
WEATHER PROTECTED II
HOLLOSHAFT®
FRAME: 5008-5012PH, P, PA

TYPES: RU & RUE

PRINTS
5008-5012
RU, RUE

Typical Dimensions For Reference Only

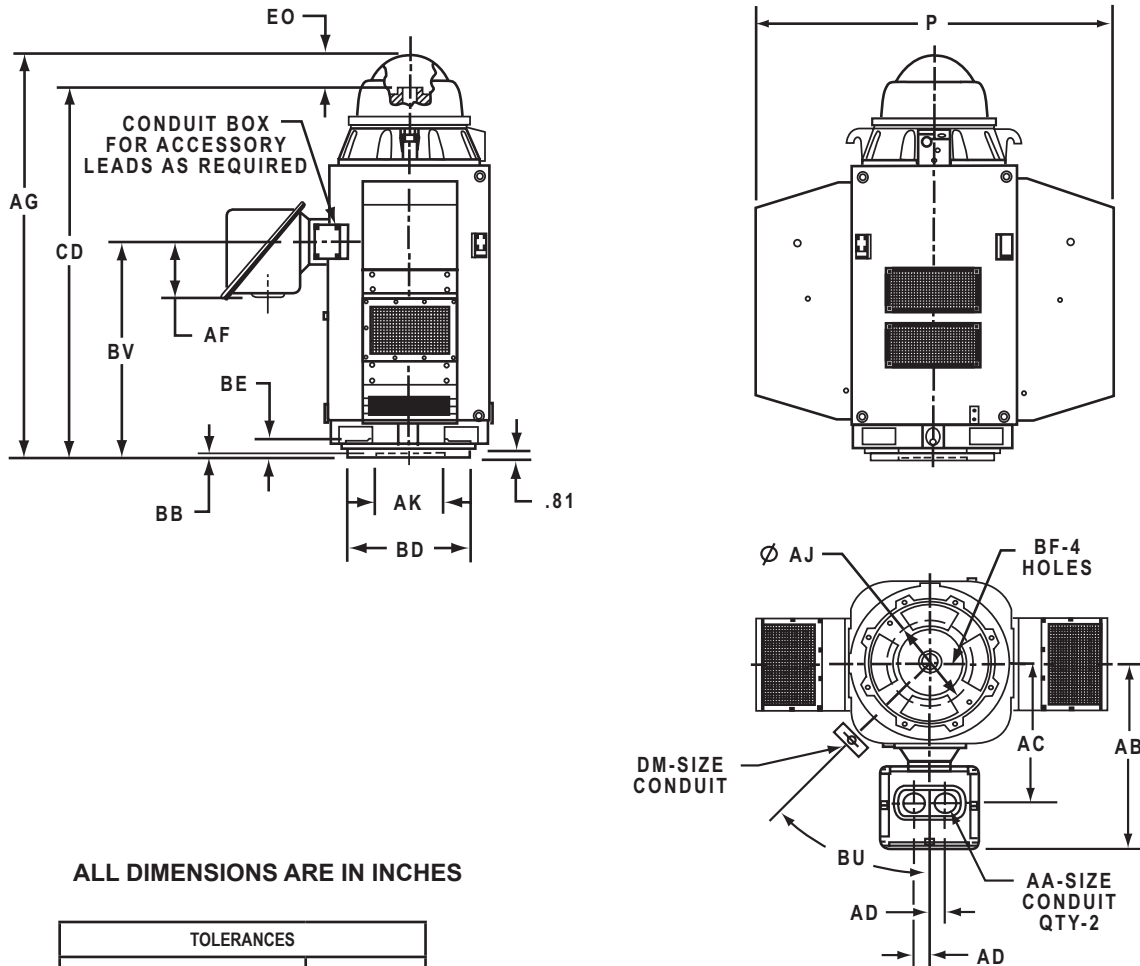

ALL DIMENSIONS ARE IN INCHES

TOLERANCES	
FACE RUNOUT	.007 T.I.R.
PERMISSIBLE ECCENTRICITY OF MOUNTING RABBET	.007 T.I.R.
MAXIMUM SHAFT END PLAY	.010

AA	DM
2 NPT	0.5 NPT
2.5 NPT	0.75 NPT
3 NPT	1 NPT
3.5 NPT	1.25 NPT
4 NPT	1.5 NPT

FRAME	P	AG	BV	CD	EO
5008	71.00	63.88	27.00	57.06	6.42
5012		78.88	42.00	72.30	

FRAME	AJ	AK +.005	BB MIN	BD MAX	BE	BF
5000PH	14.750	13.500	.25	20.00	2.19	.69
5000P ³	14.750	13.500		24.50		.69
	22.000			.94		
5000PA	26.000	22.00	30.50	.81		

VOLTS	C/BOX VOL- UME (CU. IN.)	AB	AC	AD	AF	BU
0-4800	3400	36.50	27.88	3.00	10.94	45°
4801-6900	5600	36.13	30.13	4.00	10.81	

1: DIMENSIONS MAY VARY .25" DUE TO CASTING AND/OR FABRICATION VARIATIONS.
 2: DIMENSIONS AND TOLERANCES ARE SHOWN IN INCHES.
 3: 5000P HAS TWO BOLT CIRCLES.

† All marks shown within this document are properties of their respective owners.



DIMENSIONS
WEATHER PROTECTED I
HOLLOSHAFT®
FRAME: 5813P, PA

TYPES: RU & RUE

PRINTS
5813
RU, RUE

Typical Dimensions For Reference Only

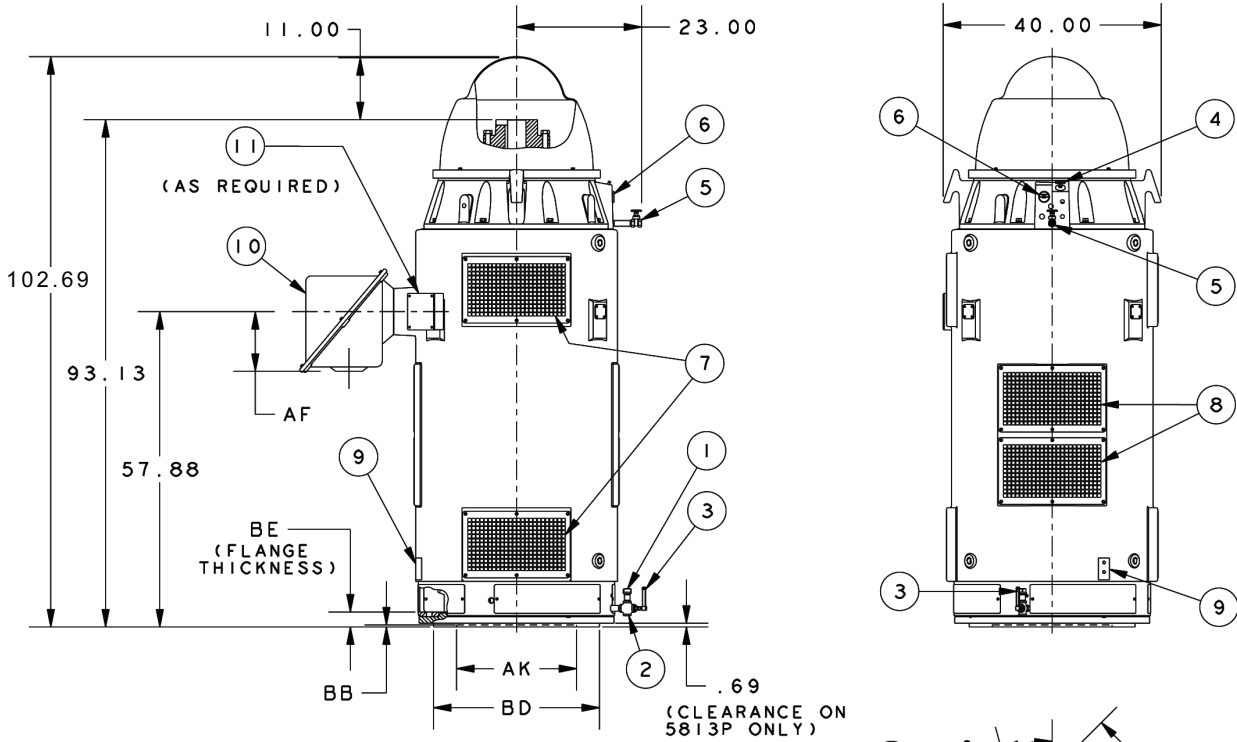

AA	DM
2 NPT	0.5 NPT
2.5 NPT	0.75 NPT
3 NPT	1 NPT
3.5 NPT	1.25 NPT
4 NPT	1.5 NPT

ALL DIMENSIONS ARE IN INCHES

FRAME	AJ	AK +.005	BB MIN	BD MAX	BE	BF	QTY. OF BF HOLES
5813P	26.000	22.000	.25	30.50	2.63	0.813	4
5813PA	32.000	26.000		36.00			

C/BOX VOLUME (CU. IN.)	AB	AC	AD	AF
.3400	39.37	30.75	3.00	10.94

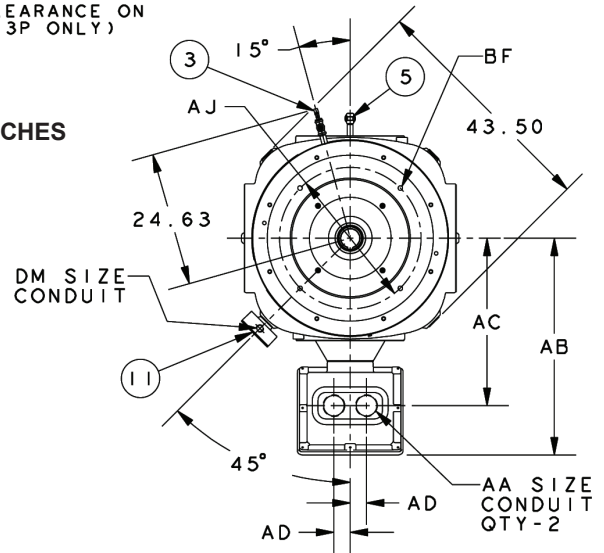

FEATURE LISTING

1	LOWER SUMP OIL FILL	6	UPPER SUMP SIGHT WINDOW	11	ACCESSORY CONDUIT BOX
2	LOWER SUMP OIL DRAIN	7	AIR INTAKE, 180° APART		
3	LOWER SUMP SIGHT WINDOW	8	AIR EXHAUST, 180° APART		
4	UPPER SUMP OIL FILL	9	GRD PADS, DIAG OPP, .50-13		
5	UPPER SUMP OIL DRAIN	10	MAIN CONDUIT BOX		

TOLERANCES	
FACE RUNOUT	.007 T.I.R.
PERMISSIBLE ECCENTRICITY OF MOUNTING RABBET	.007 T.I.R.
MAXIMUM SHAFT END PLAY	.010
NON-MACHINED DIMENSIONS MAY VARY BY ±.25	



DIMENSIONS
WEATHER PROTECTED II
HOLLOSHAFT®
FRAME: 5813P, PA

TYPE: RU & RUE

PRINTS
5813
RU & RUE

Typical Dimensions For Reference Only

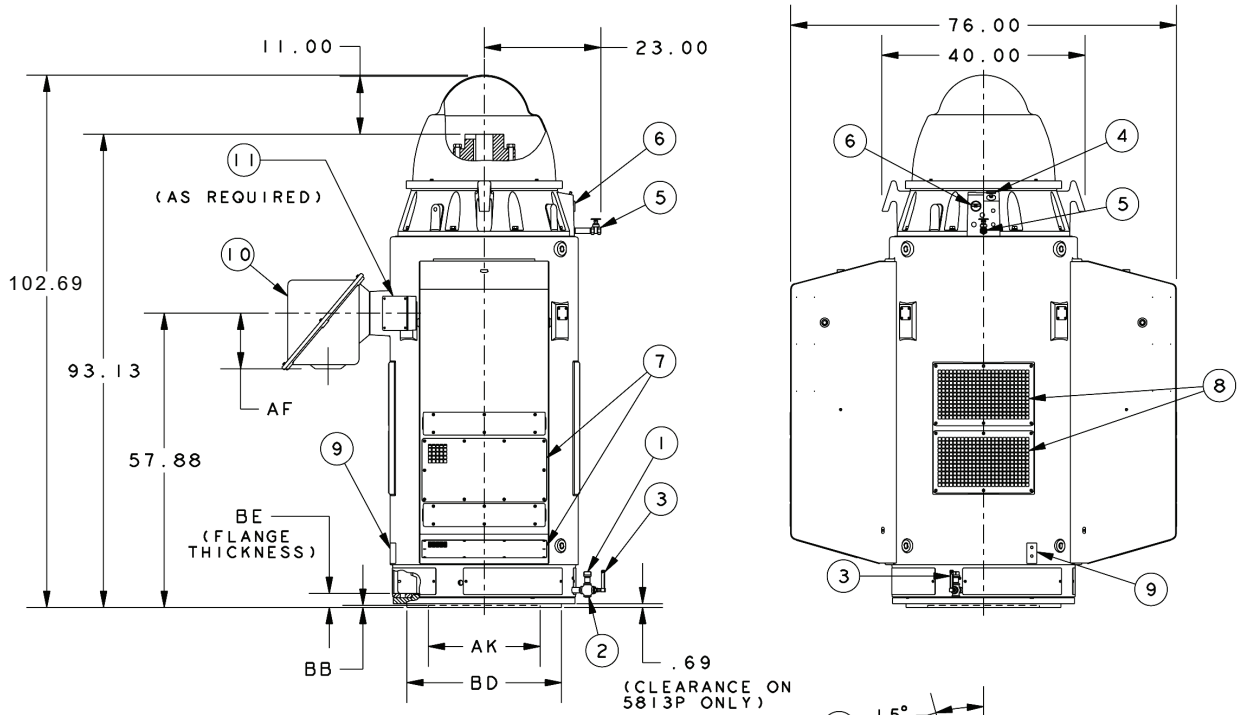

ALL DIMENSIONS ARE IN INCHES

AA	DM
2 NPT	0.5 NPT
2.5 NPT	0.75 NPT
3 NPT	1 NPT
3.5 NPT	1.25 NPT
4 NPT	1.5 NPT

FRAME	AJ	AK +.005	BB MIN	BD MAX	BE	BF	QTY. OF BF HOLES
5813P	26.000	22.000	.25	30.50	2.63	.813	4
5813PA	32.000	26.000		36.00		1.000	8

C/BOX VOLUME (CU. IN.)	AB	AC	AD	AF
.3400	39.37	30.75	3.00	10.94

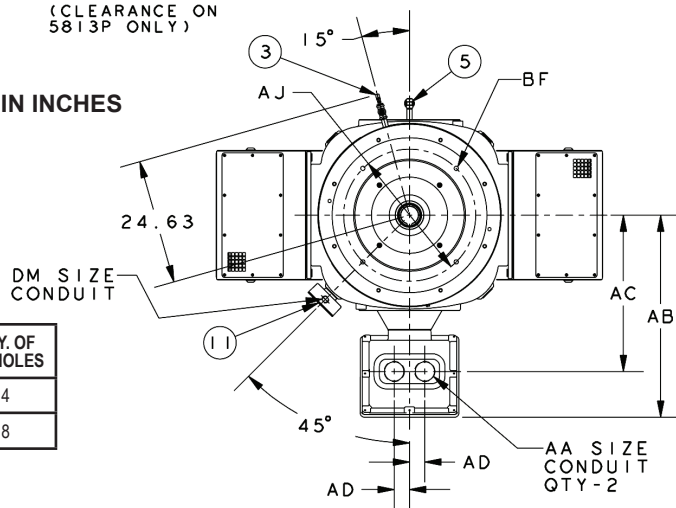

FEATURE LISTING

1	LOWER SUMP OIL FILL	6	UPPER SUMP SIGHT WINDOW	11	ACCESSORY CONDUIT BOX
2	LOWER SUMP OIL DRAIN	7	AIR INTAKE, 180° APART		
3	LOWER SUMP SIGHT WINDOW	8	AIR EXHAUST, 180° APART		
4	UPPER SUMP OIL FILL	9	GRD PADS, DIAG OPP, .50-13		
5	UPPER SUMP OIL DRAIN	10	MAIN CONDUIT BOX		

TOLERANCES

FACE RUNOUT	.007 T.I.R.
PERMISSIBLE ECCENTRICITY OF MOUNTING RABBET	.007 T.I.R.
MAXIMUM SHAFT END PLAY	.010
NON-MACHINED DIMENSIONS MAY VARY BY ±.25.	



† All marks shown within this document are properties of their respective owners.

DIMENSIONS
WEATHER PROTECTED I
HOLLOSHAFT®
FRAME: 6808 - 6810P, PA

TYPES: HU & HUE

PRINTS
6808-6810
HU, HUE

Typical Dimensions For Reference Only

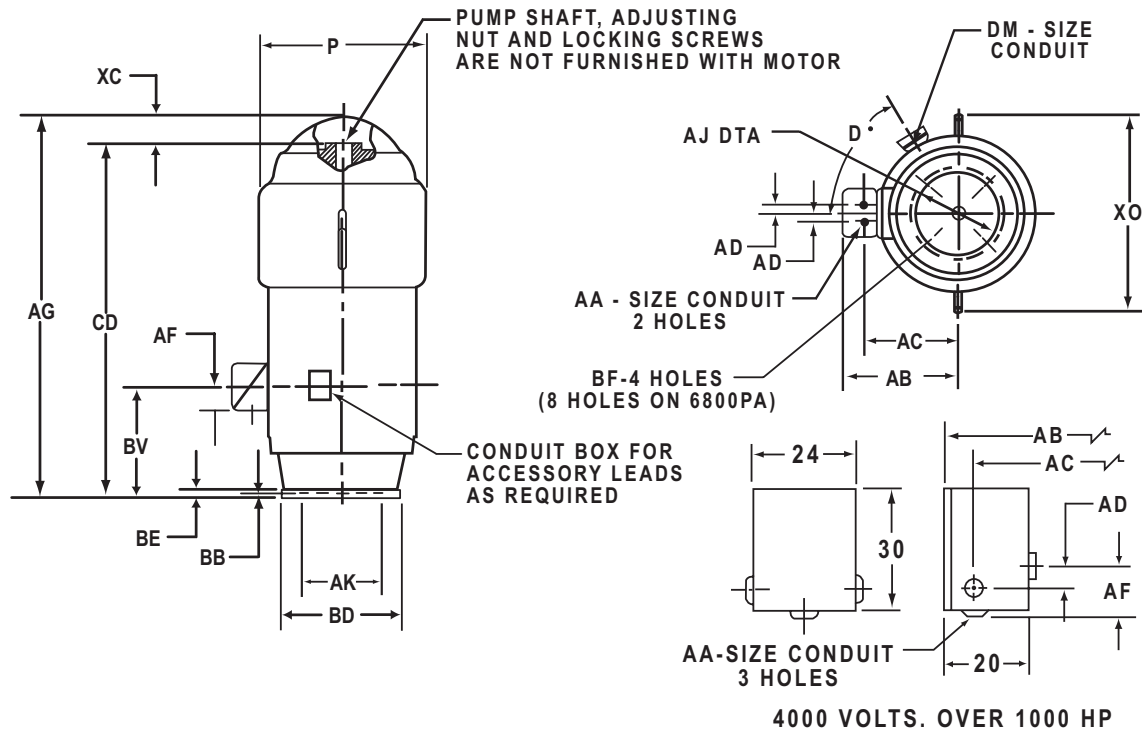

ALL DIMENSIONS ARE IN INCHES

FRAME	XO	P	AG	BV	CD	XC
6808	48.25	42.50	87.562	37.25	80.062	7.125
6810			98.562	48.25	91.062	

FRAME	BD	BE	AJ	BF	AK	BB
6800P	30.50	1.50	26	0.833	22.000	0.25
6800PA	36		32	1	26.000	

FRAME	HP	VOLT	AA	AB	AC	AD	AF	D	DM
6800	ALL	460	3.50	35.94	27.312	3	10.94	60	.75
	ALL	2300							
	THRU 1000	4000							
	1001 & UP	4000							

- ROUGH DIMENSIONS MAY VARY BY $\pm .25"$ DUE TO CASTING AND OR FABRICATION VARIATIONS.
- CONDUIT OPENINGS MAY BE LOCATED IN STEPS OF 90°. STANDARD IS AS SHOWN WITH CONDUIT OPENING DOWN.
- CONDUIT BOX FOR 4000 VOLT MOTORS OVER 1000 HP CANNOT BE ROTATED.

TOLERANCES	22.000 AK	26.000 AK
FACE RUNOUT	.007 F.I.R	.009 F.I.R
PERMISSIBLE ECCENTRICITY OF MOUNTING RABBET	.007 F.I.R	.009 F.I.R
MAXIMUM SHAFT END PLAY	.010	.010
TOLERANCE ON AK-DIMENSION	+.005	+.007



DIMENSIONS
WEATHER PROTECTED II
HOLLOSHAFT®
FRAME: 6808 - 6810P, PA

TYPES: HU & HUE

PRINTS
6808-6810
HU, HUE

Typical Dimensions For Reference Only

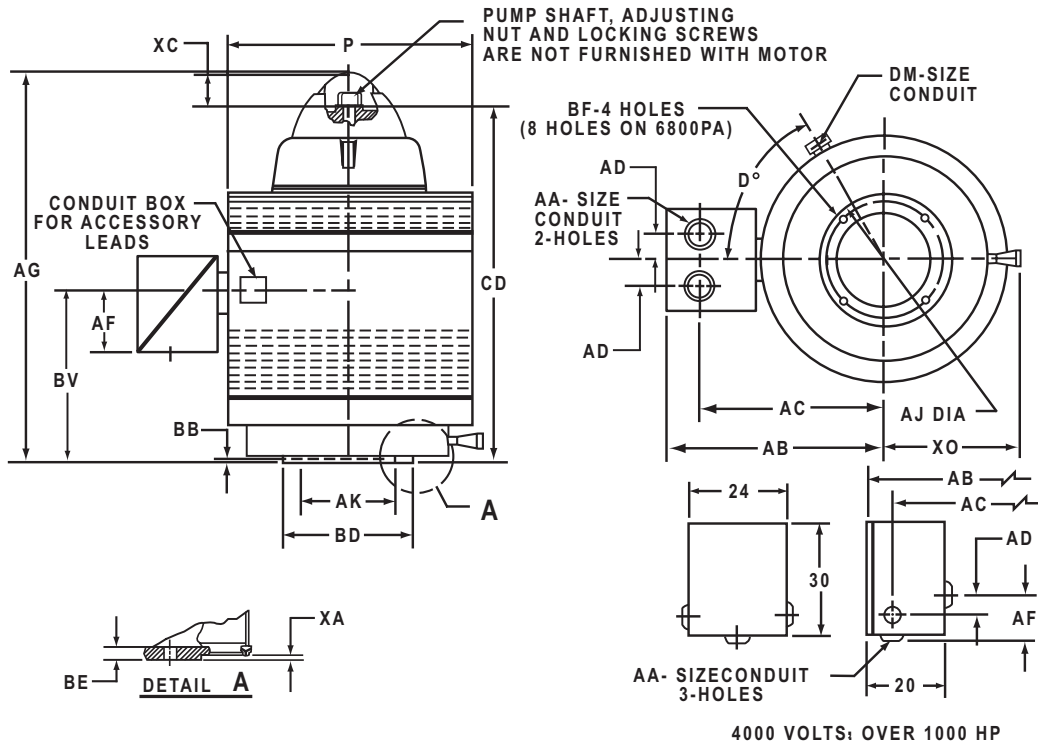

ALL DIMENSIONS ARE IN INCHES

FRAME	XO	P	AG	BV	CD	XC
6808	34.25	56.75	87.562	32.687	80.062	7.125
6810			98.562	43.687	91.062	

FRAME	BD	BE	AJ	BF	AK	BB	XA
6800P	30.50	1.50	26	0.812	22.000	0.25	0.312
6800PA	36		32	1	26.000		

FRAME	HP	VOLT	AA	AB	AC	AD	AF	D°	DM
6800	ALL	460	3.50	46.06	37.437	3	10.94	60	0.75
	ALL	2300							
	THRU 1000	4000							
	1001 & UP	4000		49.312	43.312	11	17.94		

- ROUGH DIMENSIONS MAY VARY BY $\pm .25"$ DUE TO CASTING AND OR FABRICATION VARIATIONS.
- CONDUIT OPENINGS MAY BE LOCATED IN STEPS OF 90°. STANDARD IS AS SHOWN WITH CONDUIT OPENING DOWN.
- CONDUIT BOX FOR 4000 VOLT MOTORS OVER 1000 HP CANNOT BE ROTATED.

TOLERANCES	22.000 AK	26.000 AK
FACE RUNOUT	.007 F.I.R	.009 F.I.R
PERMISSIBLE ECCENTRICITY OF MOUNTING RABBET	.007 F.I.R	.009 F.I.R
MAXIMUM SHAFT END PLAY	.010	.010
TOLERANCE ON AK-DIMENSION	+.005	+.007



† All marks shown within this document are properties of their respective owners.

DIMENSIONS
WEATHER PROTECTED I
HOLLOSHAFT®
FRAME: 6813P, PA, PB

TYPES: RU & RUE

PRINTS
449
RU & RUE

Typical Dimensions For Reference Only

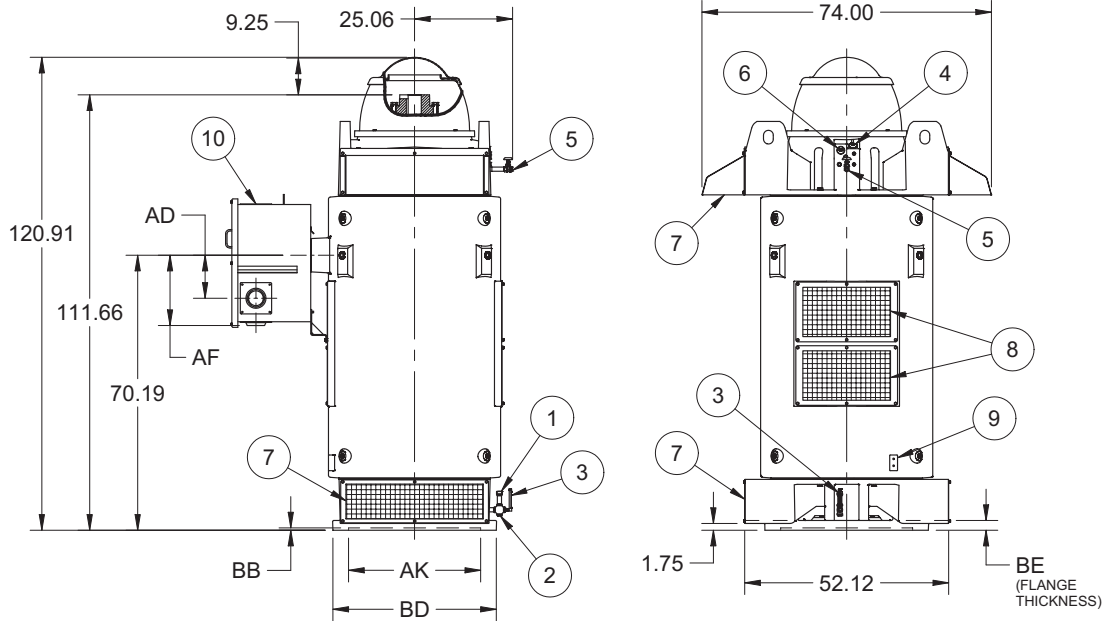

ALL DIMENSIONS ARE IN INCHES

C/BOX VOLUME (CU. IN.)	AB	AC	AD	AF	BB MIN	BE
16,200	46.56	40.31	11.00	17.81	.25	2.50

FRAME	AJ	AK +.005	BD MAX	BF
6813P	26.00	22.00	30.50	.813
6813PA	32.00	26.000	36.00	.813
6813PB	39.00	33.750	42.00	1.250

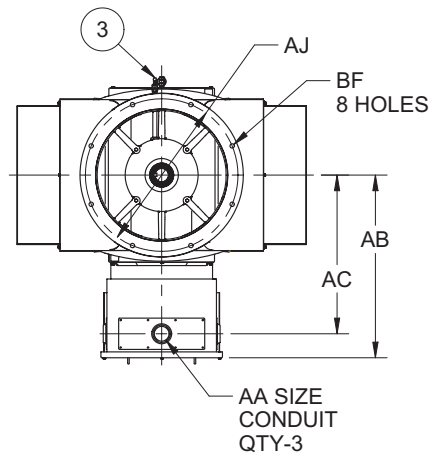

FEATURE LISTING

1	LOWER SUMP OIL FILL	6	UPPER SUMP SIGHT WINDOW
2	LOWER SUMP OIL DRAIN	7	AIR INTAKE, 180° APART
3	LOWER SUMP SIGHT WINDOW	8	AIR EXHAUST, 180° APART
4	UPPER SUMP OIL FILL	9	GRD PADS, DIAG OPP, 1/2-13
5	UPPER SUMP OIL DRAIN	10	MAIN CONDUIT BOX

- 1: ALL ROUGH CASTING DIMENSIONS MAY VARY BY .25" DUE TO CASTING VARIATIONS.
- 2: LARGEST MOTOR WIDTH.
- 3: CONDUIT OPENING MAY BE LOCATED IN STEPS OF 90. STANDARD AS SHOWN WITH CONDUIT OPENING DOWN.

TOLERANCES	
FACE RUNOUT	.009 T.I.R.
PERMISSIBLE ECCENTRICITY OF MOUNTING RABBET	.009 T.I.R.
MAXIMUM SHAFT END PLAY	.010
NON-MACHINED DIMENSIONS MAY VARY BY ±.25	



DIMENSIONS
WEATHER PROTECTED II
HOLLOSHAFT®
FRAME: 6813P, PA, PB

TYPES: RU & RUE



Typical Dimensions For Reference Only

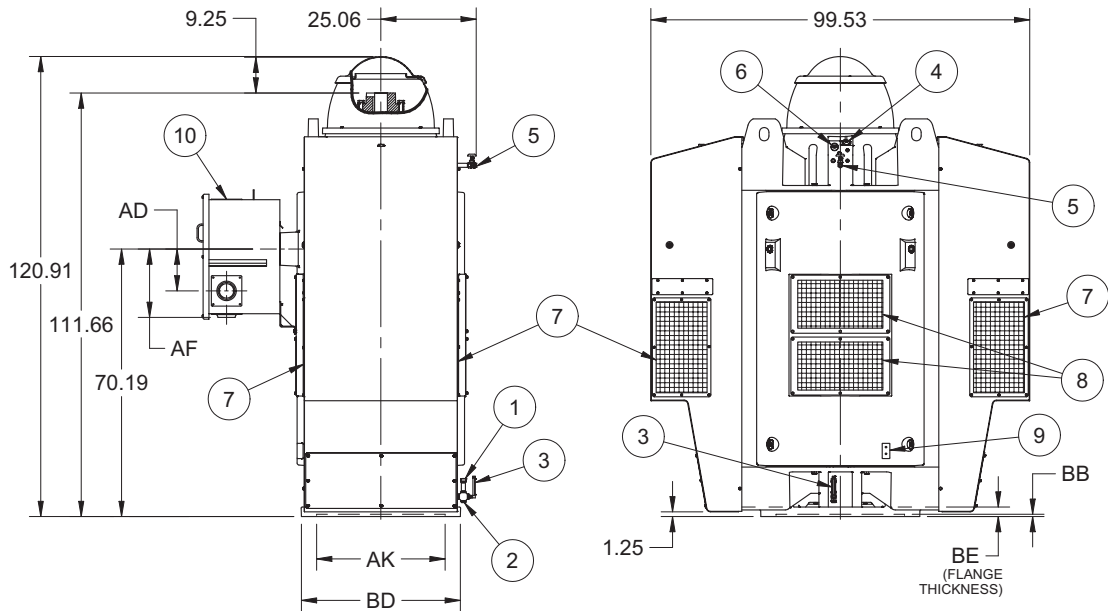

ALL DIMENSIONS ARE IN INCHES

C/BOX VOLUME (CU. IN.)	AB	AC	AD	AF	BB MIN	BE
16,200	46.56	40.31	11.00	17.81	.25	2.50

FRAME	AJ	AK +.005	BD MAX	BF
6813P	26.00	22.00	30.50	.813
6813PA	32.00	26.000	36.00	.813
6813PB	39.00	33.750	42.00	1.250

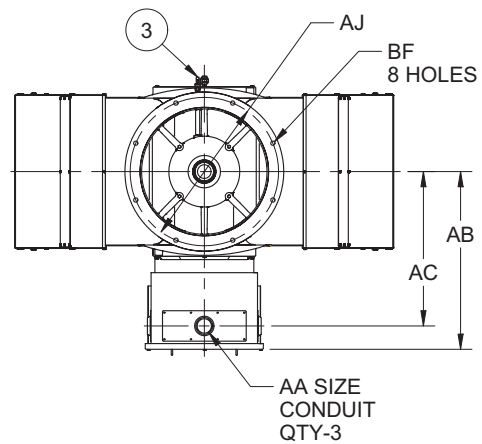

FEATURE LISTING

1	LOWER SUMP OIL FILL	6	UPPER SUMP SIGHT WINDOW
2	LOWER SUMP OIL DRAIN	7	AIR INTAKE
3	LOWER SUMP SIGHT WINDOW	8	AIR EXHAUST, 180° APART
4	UPPER SUMP OIL FILL	9	GRD PADS, DIAG OPP, 1/2-13
5	UPPER SUMP OIL DRAIN	10	MAIN CONDUIT BOX

- 1: ALL ROUGH CASTING DIMENSIONS MAY VARY BY .25" DUE TO CASTING VARIATIONS.
- 2: LARGEST MOTOR WIDTH.
- 3: CONDUIT OPENING MAY BE LOCATED IN STEPS OF 900. STANDARD AS SHOWN WITH CONDUIT OPENING DOWN.

TOLERANCES	
FACE RUNOUT	.009 T.I.R.
PERMISSIBLE ECCENTRICITY OF MOUNTING RABBIT	.009 T.I.R.
MAXIMUM SHAFT END PLAY	.010
NON-MACHINED DIMENSIONS MAY VARY BY ±.25	



† All marks shown within this document are properties of their respective owners.

DIMENSIONS
WEATHER PROTECTED I
HOLLOSHAFT®
FRAME: 8006 - 8011PH

TYPES: RU & RUE

PRINTS
8006-8011
RU, RUE

Typical Dimensions For Reference Only

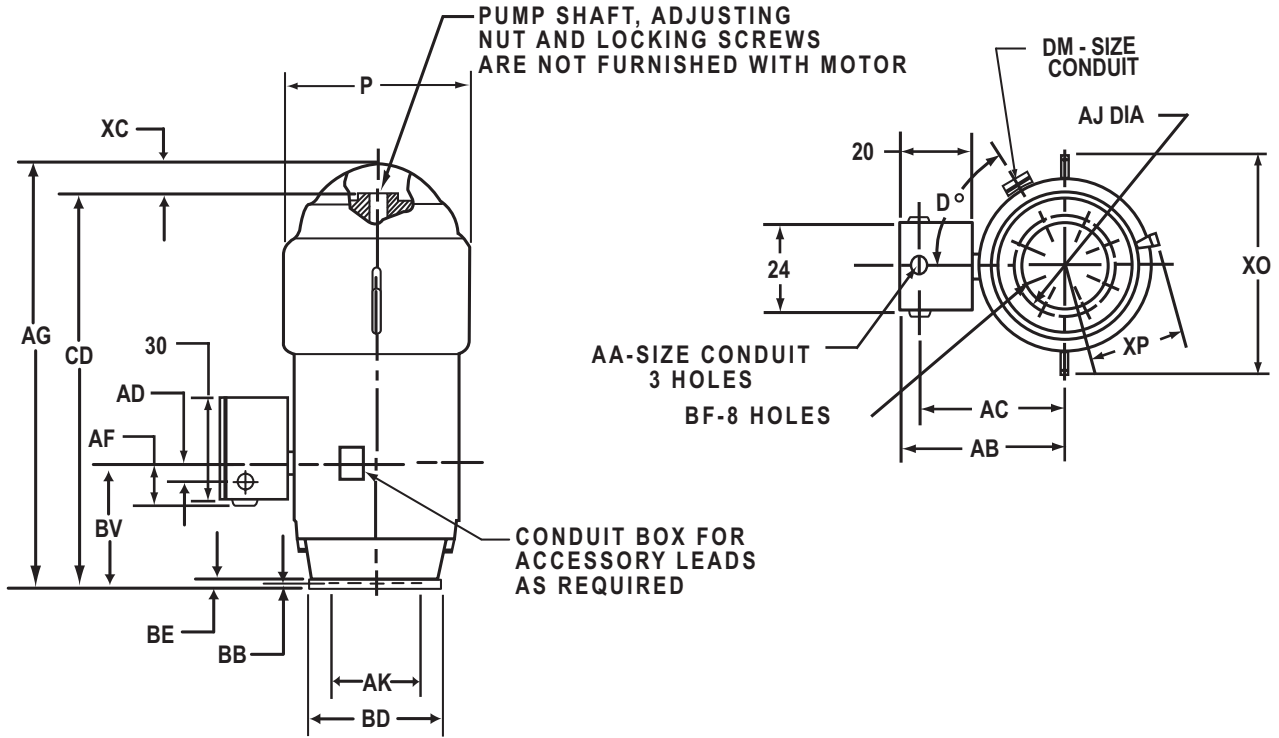

ALL DIMENSIONS ARE IN INCHES

FRAME	BD	BE	AJ	BF	AK +.007	BB
8000PH	42	1.75	39	1.125	33.750	0.25

FRAME	XP	XD	P	AG	BV	CD	XC
8006	25	48.25	45	92.062	33.75	84.562	7.125
8007				96.062	37.75	88.562	
8008				100.062	41.75	92.562	
8009				104.062	45.75	96.562	
8010				108.062	49.75	100.562	
8011				112.062	53.75	104.562	

FRAME	HP	VOLT	AA	AB	AC	AD	AF	D°	DM
8000	ALL	ALL	3.50	43.437	37.437	11	17.81	45	1

TOLERANCES	
FACE RUNOUT	.009 F.I.R
PERMISSIBLE ECCENTRICITY OF MOUNTING RABBET	.009 F.I.R
MAXIMUM SHAFT END PLAY	.010

1: ROUGH DIMENSIONS MAY VARY BY ±.25" DUE TO CASTING AND OR FABRICATION VARIATIONS.

† All marks shown within this document are properties of their respective owners.



DIMENSIONS
WEATHER PROTECTED II
HOLLOSHAFT®
FRAME: 8006 - 8011PH

TYPE: RU & RUE

PRINTS
8006-8011
RU, RUE

Typical Dimensions For Reference Only

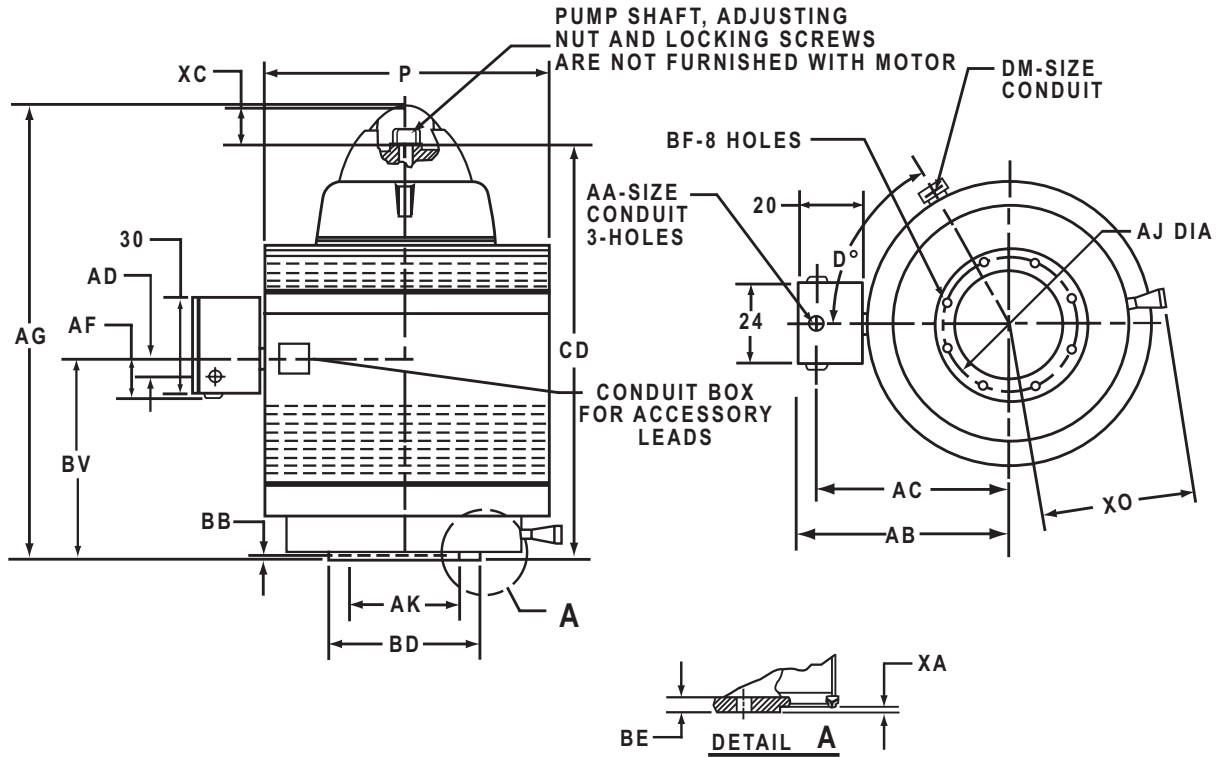

ALL DIMENSIONS ARE IN INCHES

FRAME	XP	P	AG	BV	CD	XC
8006	37.375	67.437	92.062	33.75	84.562	7.125
8007			96.062	37.75	88.562	
8008			100.062	41.75	92.562	
8009			104.062	45.75	96.562	
8010			108.062	49.75	100.562	
8011			112.062	53.75	104.562	

FRAME	BD	BE	AJ	BF	AK +.007	BB	XA
8000PH	42	1.75	39	1.125	33.750	0.25	1

FRAME	HP	VOLT	AA	AB	AC	AD	AF	D°	DM
8000	ALL	ALL	3.50	54.687	48.687	11	17.81	45	1

TOLERANCES	
FACE RUNOUT	.009 F.I.R
PERMISSIBLE ECCENTRICITY OF MOUNTING RABBET	.009 F.I.R
MAXIMUM SHAFT END PLAY	.010

1: ROUGH DIMENSIONS MAY VARY BY $\pm .25"$ DUE TO CASTING AND OR FABRICATION VARIATIONS.

† All marks shown within this document are properties of their respective owners.



DIMENSIONS
WEATHER PROTECTED I
HOLLOSHAFT®
FRAME: 9601 - 9608PH

TYPES: RU & RUE

PRINTS
9601-9608
RU, RUE

Typical Dimensions For Reference Only

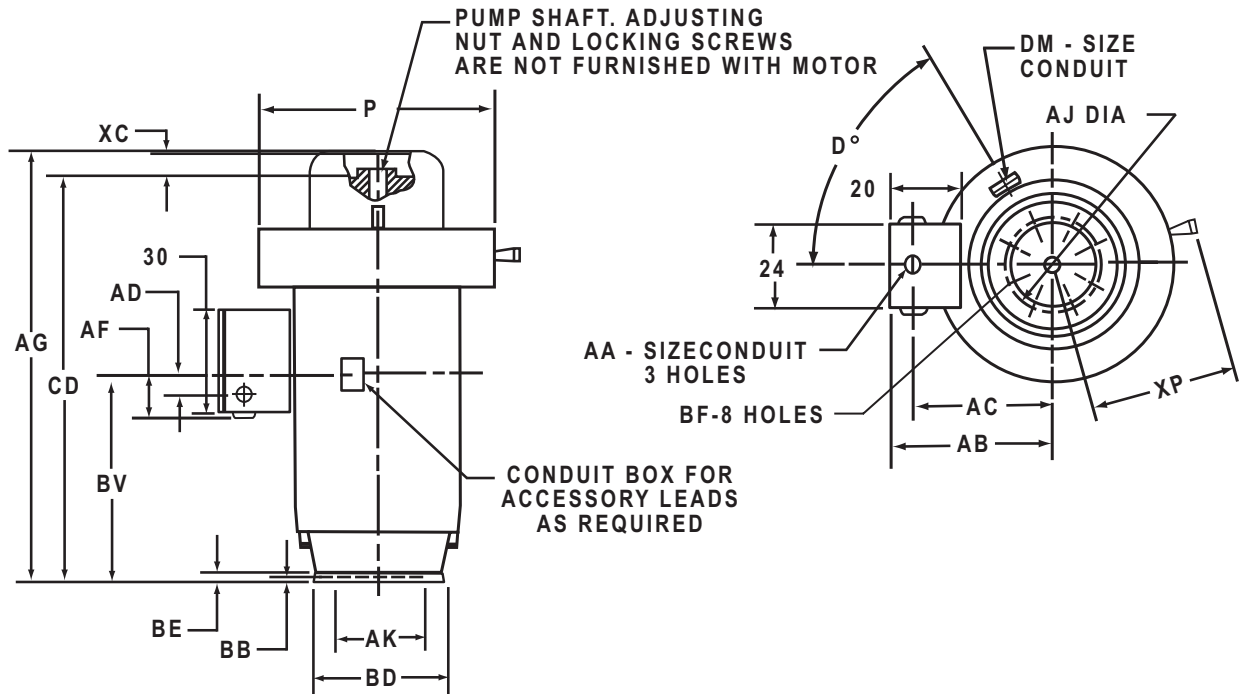

ALL DIMENSIONS ARE IN INCHES

FRAME	BD	BE	AJ	BF	AK +.007	BB
9600PH	42	1.50	39	1.125	33.750	0.25

FRAME	XP	P	AG	BV	CD	XC
9601	37.125	62.625	98.25	35.75	85.031	12.875
9602			102.25	39.75	89.031	
9603			106.25	43.75	93.031	
9604			110.25	47.75	97.031	
9605			114.25	51.75	101.031	
9606			118.25	55.75	105.031	
9607			122.25	59.75	109.031	
9608			126.25	63.75	113.031	

FRAME	HP	VOLT	AA	AB	AC	AD	AF	D°	DM
9600	ALL	ALL	3.50	47.375	41.375	11	17.937	90	1

TOLERANCES	
FACE RUNOUT	.009 F.I.R
PERMISSIBLE ECCENTRICITY OF MOUNTING RABBET	.009 F.I.R
MAXIMUM SHAFT END PLAY	.010

1: ROUGH DIMENSIONS MAY VARY BY ± 1/4" DUE TO CASTING AND OR FABRICATION VARIATIONS.

† All marks shown within this document are properties of their respective owners.



DIMENSIONS
WEATHER PROTECTED II
HOLLOSHAFT®
FRAME: 9601 - 9608PH

TYPES: RU & RUE

PRINTS
9601-9608
RU, RUE

Typical Dimensions For Reference Only

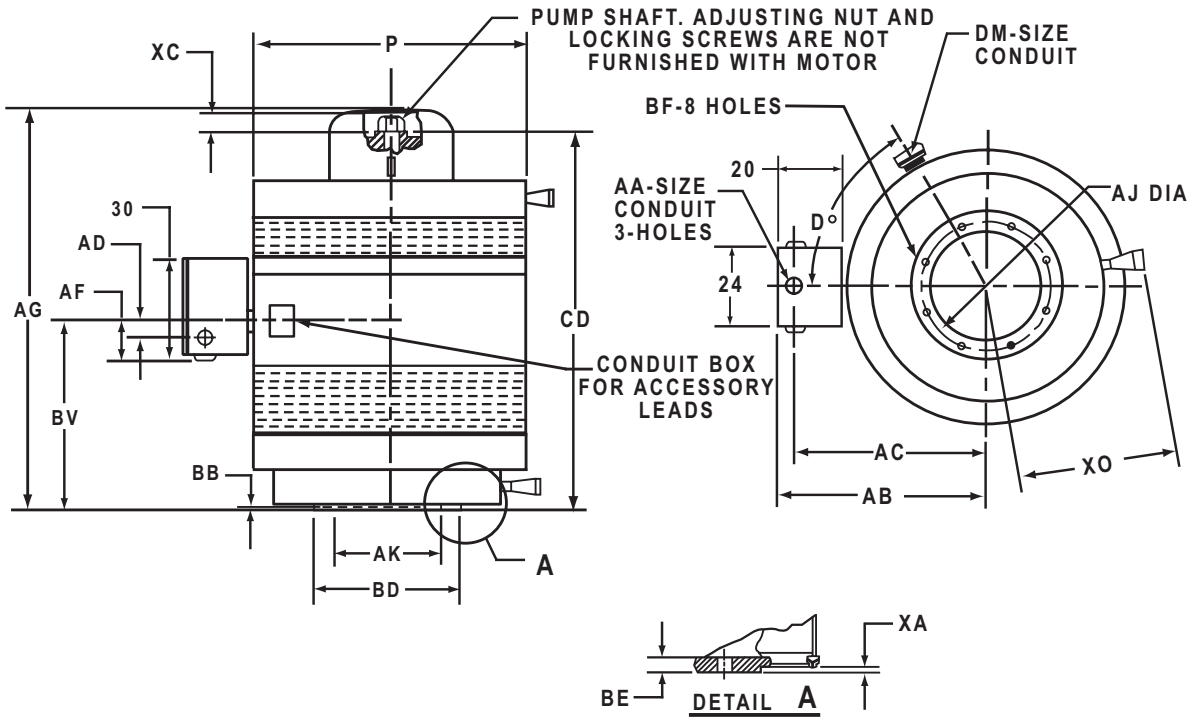

ALL DIMENSIONS ARE IN INCHES

FRAME	XO	P	AG	BV	CD	XC
9601	43.875	72.25	98.25	35.75	85.031	12.875
9602			102.25	39.75	89.031	
9603			106.25	43.75	93.031	
9604			110.25	47.75	97.031	
9605			114.25	51.75	101.031	
9606			118.25	55.75	105.031	
9607			122.25	59.75	109.031	
9608			126.25	63.75	113.031	

FRAME	BD	BE	AJ	BF	AK +.007	BB	XA
9600PH	42	1.50	39	1.125	33.750	0.25	1

FRAME	HP	VOLT	AA	AB	AC	AD	AF	D	DM
9600	ALL	ALL	3.50	56.875	50.875	11	17.937	90	1

TOLERANCES	
FACE RUNOUT	.009 F.I.R
PERMISSIBLE ECCENTRICITY OF MOUNTING RABBET	.009 F.I.R
MAXIMUM SHAFT END PLAY	.010

1: ROUGH DIMENSIONS MAY VARY BY ±1/4" DUE TO CASTING AND OR FABRICATION VARIATIONS.

† All marks shown within this document are properties of their respective owners.



DIMENSIONS
TOTALLY ENCLOSED FAN COOLED
HOLLOSHAFT®

FRAME: 182TP - 286TPH

TYPES: TU, TUE, TUS & TUI

PRINTS
182-286
TU, TUE
TUS, TUI

Typical Dimensions For Reference Only

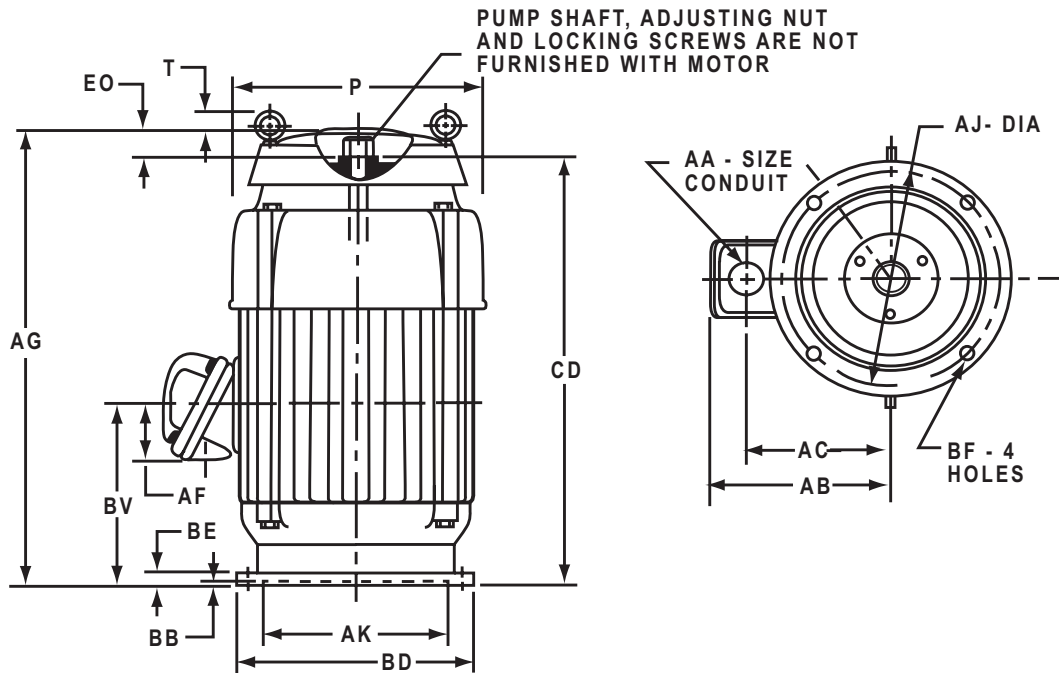

ALL DIMENSIONS ARE IN INCHES

BASIC FRAME	BE	BV	CD	EO
180, 210	0.75	8.38	17.562	3.000
250	1	10.437	22.937	2.937
280	1	12.437	26.562	2.937

FRAME	AJ	AK	BB	BD	BF
182, 184, 213, 215 254, 256, 284, 286TP	9.125	8.25	.187	10	0.437
254, 256TPH, 284, 286TPA	9.125	8.25	0.187	12	0.437
284, 286TPH	14.75	13.25	0.25	16.50	0.687

BASIC FRAME	p ²	T	AA	AB	AC	AF	AG
180, 210	12.875	1.50	1	7.66	6.50	3.312	21.25
250	14.466	1.125	1.25	10.25	7.88	3.687	26.25
280	14.466	1.125	1.25	11.09	8.32	4.437	29.88

TOLERANCES	8.25 AK	13 - 1/2 AK
"AK" DIMENSION	-.000; + .003	-.000; + .005
FACE RUNOUT	.004 T.I.R.	.007 T.I.R.
PERMISSIBLE ECCENTRICITY OF MOUNTING RABBET	.004 T.I.R.	.007 T.I.R.

- 1: ALL ROUGH CASTING DIMENSIONS MAY VARY BY .25" DUE TO CASTING VARIATIONS.
- 2: LARGEST MOTOR WIDTH.
- 3: CONDUIT BOX MAY BE LOCATED IN STEPS OF 90° STANDARD AS SHOWN WITH CONDUIT OPENING DOWN.

† All marks shown within this document are properties of their respective owners.



DIMENSIONS
TOTALLY ENCLOSED FAN COOLED
HOLLOSHAFT®
FRAME: 324TP - 447TPA

TYPES: TU, TUE, TUS & TUI

PRINTS
324-447
TU, TUE
TUS, TUI

Typical Dimensions For Reference Only

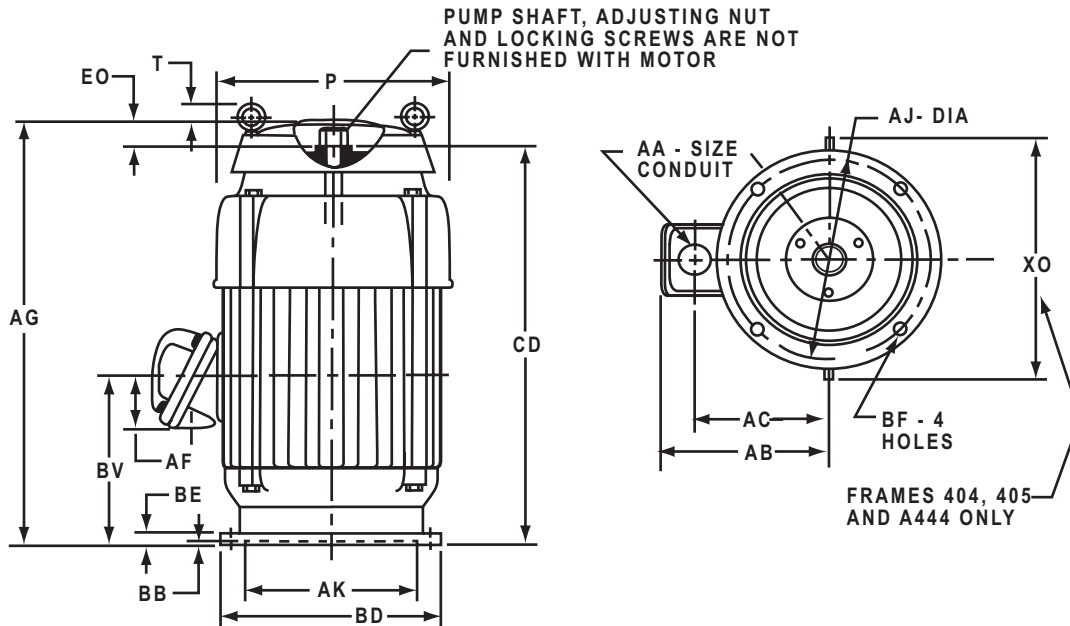

ALL DIMENSIONS ARE IN INCHES

BASIC FRAME	P	T	AA	AG	AJ	AK	BB	BE
320TP	17	-1.25	2	35.625	14.75	13.50	0.25	1
320TPH	17	-1.25	2	35.625	9.125	8.25	0.187	1
360TP	18.75	-1.687	3	36.125	14.75	13.50	0.25	1
400	24.312	---	3	46.437	14.75	13.50	0.25	1
444, 445TP	23.25	---	3	47.56	14.75	13.50	0.25	1
447TP	23.25	---	3	51.06	14.75	13.50	0.25	1

BASIC FRAME	BF	BV	CD	EO	XO
320TP	0.687	11.937	28.50	6.875	---
320TPH	0.437	11.937	28.50	6.875	---
360TP	0.687	13.00	30	5.937	---
400TP	0.687	15.625	39.94	6.062	24.625
444, 445TP	0.687	16.50	42.5	4.625	28.94
447TP	0.687	18.25	46.0	4.625	28.94

FRAME	AB	AC	AF	BD
324, 326TP	14.125	10.75	3.25	16.50
324, 326TPH	14.125	10.75	3.25	12
364, 365TP	16.50	12.25	3.38	16.50
404, 405TP	17.75	13.50	3.38	16.50
404, 405TPA	17.75	13.50	3.38	20.00
444, 445, 447TP	19.38	14.88	4.72	16.50
444, 445, 447TPA	19.38	14.88	4.72	20

TOLERANCES	8.25 AK	13 - 1/2 AK
FACE RUNOUT	.004 T.I.R.	.007 T.I.R.
PERMISSIBLE ECCENTRICITY OF MOUNTING RABBET	.004 T.I.R.	.007 T.I.R.
"AK" DIMENSION	-.000:+.003	-.000:+.005

- 1: ALL ROUGH CASTING DIMENSIONS MAY VARY BY .25" DUE TO CASTING VARIATIONS.
- 2: LARGEST MOTOR WIDTH.
- 3: CONDUIT BOX MAY BE LOCATED IN STEPS OF 90° STANDARD AS SHOWN WITH CONDUIT OPENING DOWN.
- 4: (-) MINUS SIGN INDICATES EYEBOL IS BELOW THE TOP OF THE UNIT

† All marks shown within this document are properties of their respective owners.



DIMENSIONS
TOTALLY ENCLOSED FAN COOLED
HOLLOSHAFT®
FRAME: 449TP

TYPES: JU & JUE

PRINTS
449
JU, JUE

Typical Dimensions For Reference Only

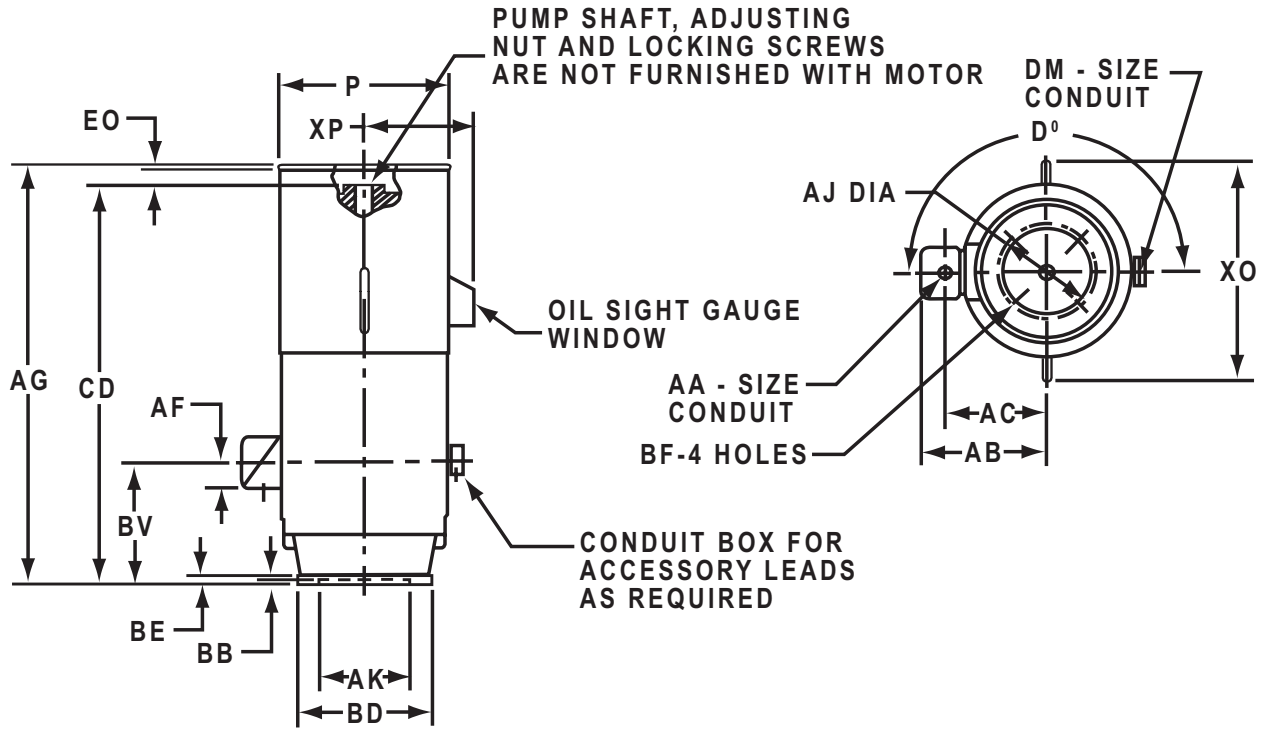

ALL DIMENSIONS ARE IN INCHES

FRAME	BD	BE	AJ	BF	AK +.005	BB	P	X0	XP
449TP	24.50	0.875	14.75	0.687	13.500	0.25	26.25	33	14.50
449TPH	20								

FRAME	HP	VOLTS	AA	AB	AC	AF	D°	DM	AG	BV	CD	EO
449	ALL	460	3.50	24	18.50	8.062	180	0.75	63.875	12.50	56.875	4.50
	ALL	2300										
	ALL	4000		25	19.50	10						

TOLERANCES	
FACE RUNOUT	.007 F.I.R
PERMISSIBLE ECCENTRICITY OF MOUNTING RABBET	.007 F.I.R
MAXIMUM SHAFT END PLAY	.010

- 1: ROUGH DIMENSIONS MAY VARY BY +/- 1/4" DUE TO CASTING AND OR FABRICATION VARIATIONS.
- 2: CONDUIT OPENINGS MAY BE LOCATED IN STEPS OF 90°. STANDARD IS AS SHOWN WITH CONDUIT OPENING DOWN.



DIMENSIONS
HAZARDOUS LOCATION
HOLLOSHAFT®
FRAME: 182TP - 286TPH

TYPES: LU & LUE

PRINTS
182-286
LU, LUE

Typical Dimensions For Reference Only

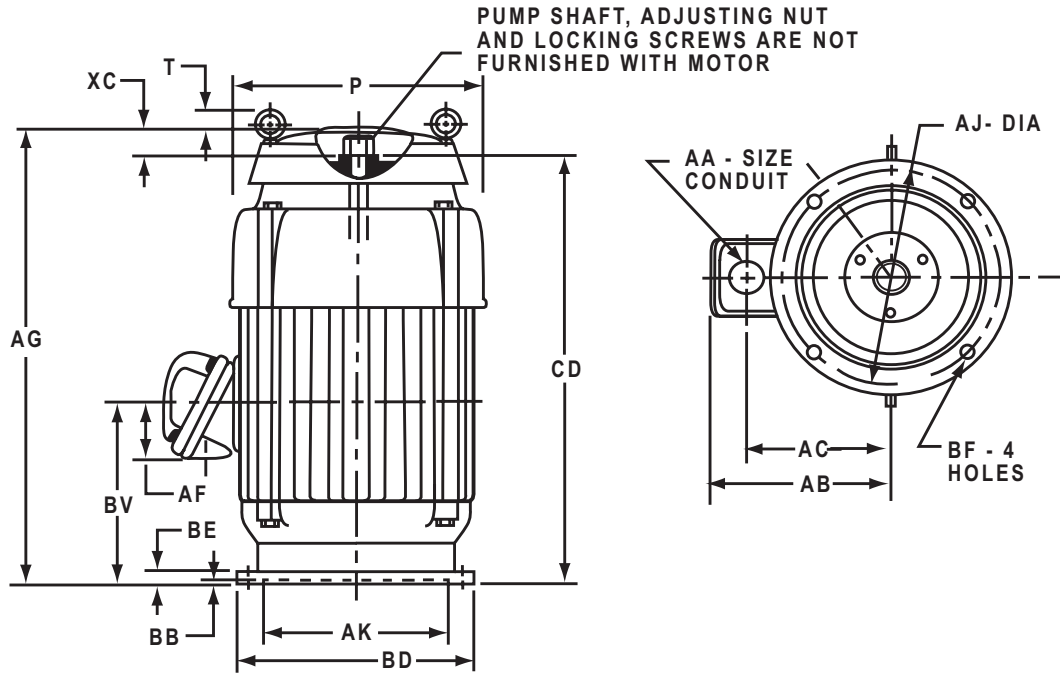

ALL DIMENSIONS ARE IN INCHES

BASIC FRAME	BE	BV	CD	XC
180, 210	0.75	8	17.50	3.312
250	0.593	10	22.937	5.50
280	0.906	11.187	26.562	5.875

FRAME	AJ	AK	BB	BD	BF
182, 184, 213, 215 254, 256, 284, 286TP	9.125	8.25	0.187	10	0.437
254, 256TPH, 284, 286TPA	9.125	8.25	0.187	12	0.437
284, 286TPH	14.75	13.50	0.25	16.50	0.687

BASIC FRAME	P ²	T	AA	AB	AC	AF	AG
180, 210	11.062	1.333	1	9.062	6.812	2.625	21.125
250	13.8125	▲ -1	1.50	11.06	8.25	3.125	28.625
280	14.75	▲ -1.312	2	13.125	9.625	3.875	32.625

TOLERANCES	8.25 AK	13.5 AK
"AK" DIMENSION	-0.00:+.003	-0.00:+.005
FACE RUNOUT	.004 T.I.R.	.007 T.I.R.
PERMISSIBLE ECCENTRICITY OF MOUNTING RABBET	.004 T.I.R.	.007 T.I.R.

- ALL ROUGH CASTING DIMENSIONS MAY VARY BY 1/4" DUE TO CASTING VARIATIONS.
 - LARGEST MOTOR WIDTH.
 - CONDUIT BOX MAY BE LOCATED IN STEPS OF 90° STANDARD AS SHOWN WITH CONDUIT OPENING DOWN.
- ▲ (-) MINUS SIGN INDICATES EYEBOLT IS BELOW THE TOP OF THE UNIT

† All marks shown within this document are properties of their respective owners.



DIMENSIONS
HAZARDOUS LOCATION
HOLLOSHAFT®
FRAME: 324TP - 447TPA

TYPES: LU & LUE

PRINTS
324-447
LU, LUE

Typical Dimensions For Reference Only

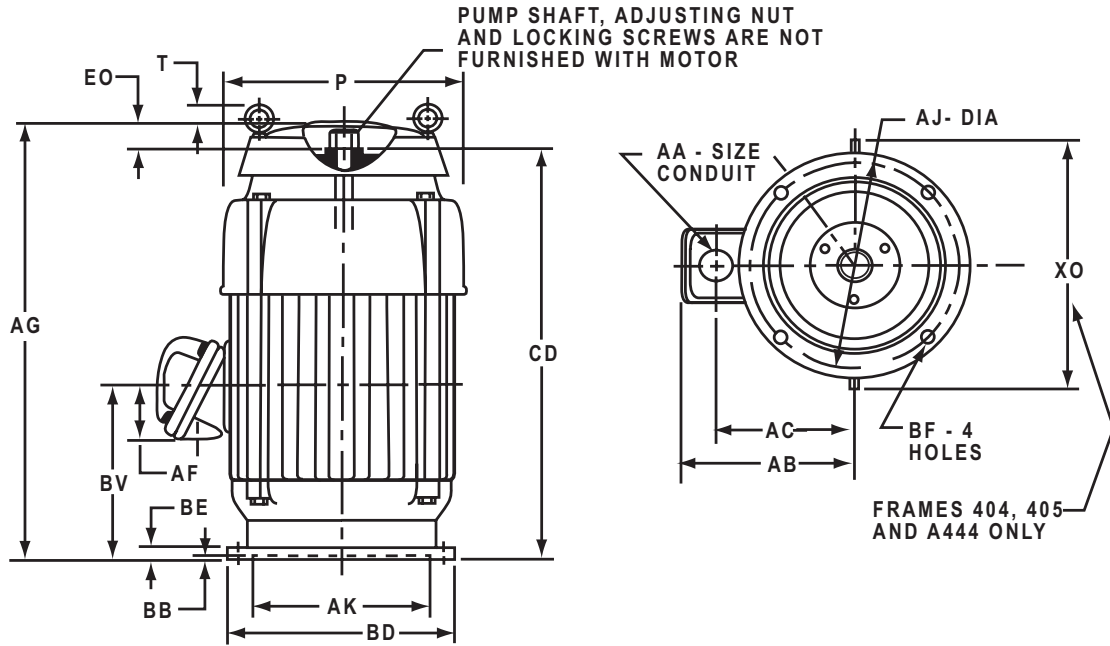

ALL DIMENSIONS ARE IN INCHES

BASIC FRAME	p ²	T ⁴	AA	AG	AJ	AK	BB	BE
320TP	17	-1.25	2	35.625	14.75	13.50	0.25	1
320TPH	17	-1.25	2	35.625	9.125	8.25	0.187	1
360TP	18.75	-1.687	3	36.125	14.75	13.50	0.25	1
400	24.312	---	3	46.437	14.75	13.50	0.25	1
444, 445TP	23.25	---	3	48.125	14.75	13.50	0.25	1
447TP	23.25	---	3	51.625	14.75	13.50	0.25	1

BASIC FRAME	BF	BV	CD	EO	XO
320TP	0.687	11.937	28.5	6.875	---
320TPH	0.437	11.937	28.5	6.875	---
360TP	0.687	13	30.0	5.937	---
400TP	0.687	15.625	39.94	6.062	24.625
444, 445TP	0.687	16.50	42.5	4.625	28.94
447TP	0.687	18.25	46.0	4.625	28.94

FRAME	AB	AC	AF	BD
324, 326TP	14.25	10.75	3.875	16.50
324, 326TPH	14.25	10.75	3.875	12
364, 365TP	17.56	12.25	4.56	16.50
404, 405TP	18.81	13.75	4.56	16.50
404, 405TPA	17.75	13.50	3.38	20.00
444, 445, 447TP	19.38	14.88	4.72	16.50
444, 445, 447TPA	19.625	14.625	4.562	20

- 1: ALL ROUGH CASTING DIMENSIONS MAY VARY BY 1/4" DUE TO CASTING VARIATIONS.
- 2: LARGEST MOTOR WIDTH.
- 3: CONDUIT BOX MAY BE LOCATED IN STEPS OF 90° STANDARD AS SHOWN WITH CONDUIT OPENING DOWN.
- 4: (-) MINUS SIGN INDICATES EYEBOL IS BELOW THE TOP OF THE UNIT

TOLERANCES	8.25 AK	13.5 AK
FACE RUNOUT	.004 T.I.R.	.007 T.I.R.
PERMISSIBLE ECCENTRICITY OF MOUNTING RABBET	.004 T.I.R.	.007 T.I.R.
"AK" DIMENSION	-.000; +.003	-.000; +.005



DIMENSIONS
HAZARDOUS LOCATION
HOLLOSHAFT®
FRAME: 5008P, PH

TYPES: EU & EUE

PRINTS
5008
EU, EUE

Typical Dimensions For Reference Only

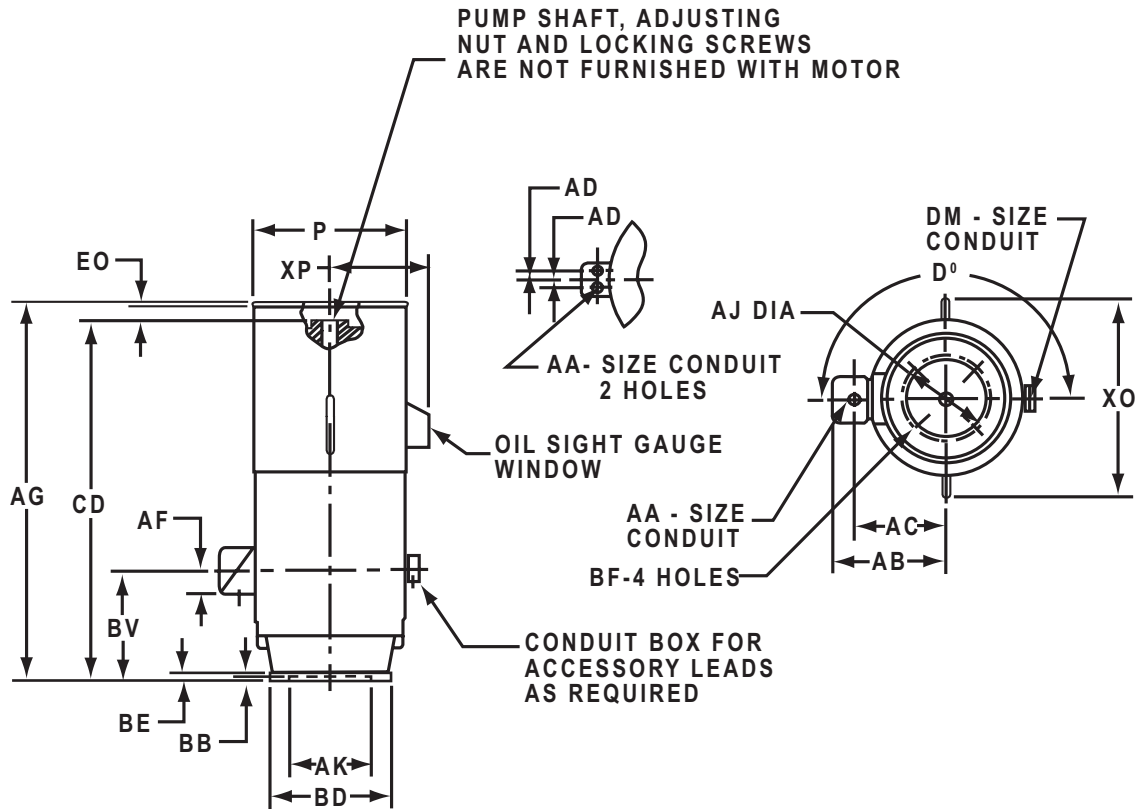

ALL DIMENSIONS ARE IN INCHES

FRAME	BD	BE	AJ	BF	AK +.005	BB	P	XO	XP
5008P	24.50	1.25	14.75	0.69	13.500	0.25	27.50	33.625	16.50
5008PH	20								

FRAME	VOLTS	AA	AB	AC	AD	AF	D°	DM	AG	BV	CD	EO
5008	460	3.50	24	17.833	---	5.625	157.5	0.75	63.625	23.75	56.50	6.625
	2300											
	4000											

TOLERANCES	
FACE RUNOUT	.007 F.I.R
PERMISSIBLE ECCENTRICITY OF MOUNTING RABBET	.007 F.I.R
MAXIMUM SHAFT END PLAY	.010

- 1: ROUGH DIMENSIONS MAY VARY BY +/- 1/4" DUE TO CASTING AND OR FABRICATION VARIATIONS.
- 2: CONDUIT OPENINGS MAY BE LOCATED IN STEPS OF 90°. STANDARD IS AS SHOWN WITH CONDUIT OPENING DOWN.

† All marks shown within this document are properties of their respective owners.



DIMENSIONS
TEFC
HOLLOSHAFT®
FRAME: 5812P, PA

TYPES: JU & JUE

PRINTS
5812
JU, JUE

Typical Dimensions For Reference Only

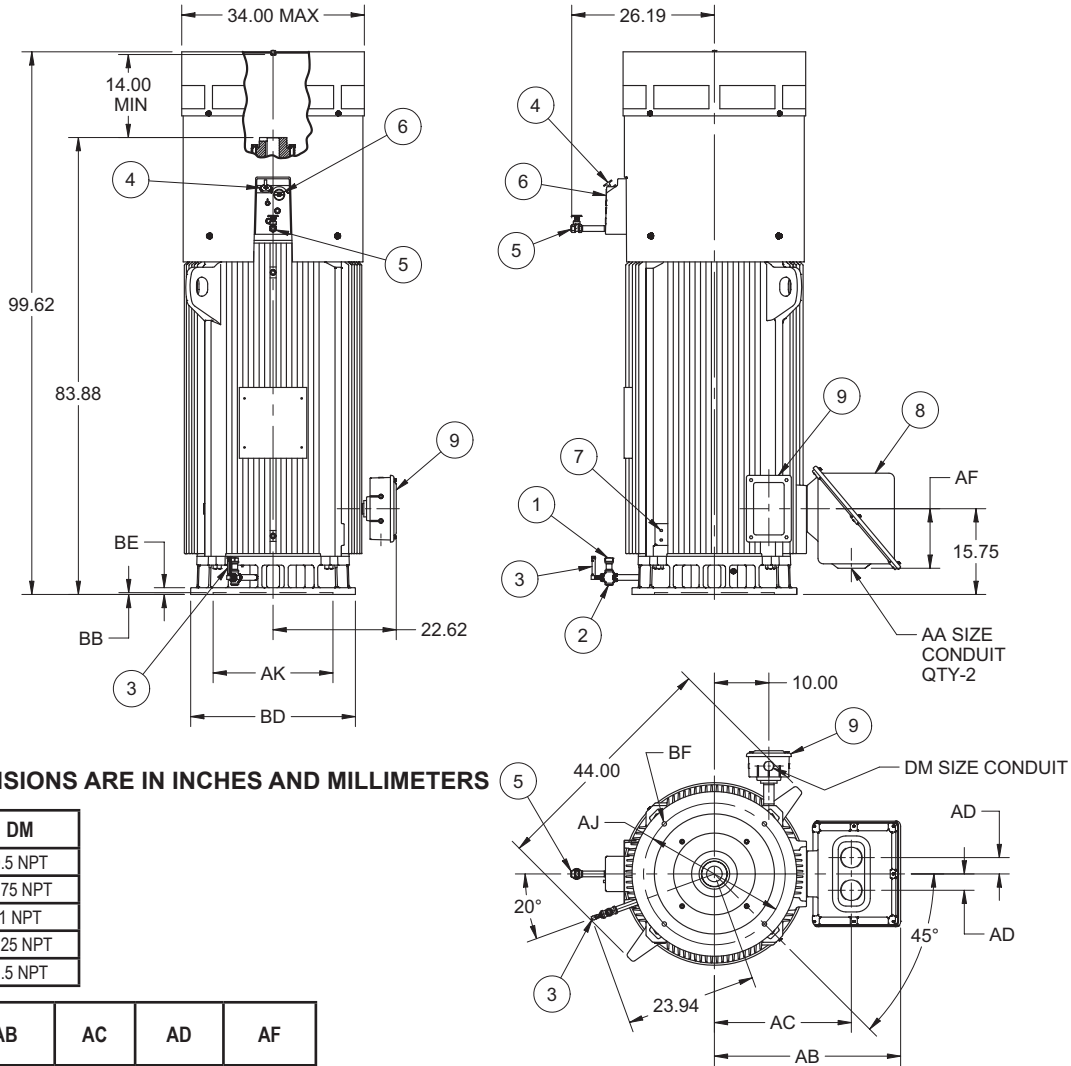

ALL DIMENSIONS ARE IN INCHES AND MILLIMETERS

AA	DM
2 NPT	0.5 NPT
2.5 NPT	0.75 NPT
3 NPT	1 NPT
3.5 NPT	1.25 NPT
4 NPT	1.5 NPT

C/BOX VOLUME (CU. IN.)	AB	AC	AD	AF
3400	34.19	25.13	3.00	10.94

FRAME	AJ	AK ±.005	BB MIN	BD MAX	BE	BF	QTY. OF BF HOLES
5812P	26.00	22.000	.25	30.50	1.25	.813	4
5812PA	32.00	26.000		36.00		1.000	8

FEATURE LISTING

1	LOWER SUMP OIL FILL	6	UPPER SUMP SIGHT WINDOW		
2	LOWER SUMP OIL DRAIN	7	GRD PADS, DIAG OPP, .50-13		
3	LOWER SUMP SIGHT WINDOW	8	MAIN CONDUIT BOX		
4	UPPER SUMP OIL FILL	9	ACCESSORY CONDUIT BOX		
5	UPPER SUMP OIL DRAIN	10			

TOLERANCES

FACE RUNOUT	.007 T.I.R.
PERMISSIBLE ECCENTRICITY OF MOUNTING RABBET	.007 T.I.R.
MAXIMUM SHAFT END PLAY	.010
NON-MACHINED DIMENSIONS MAY VARY BY ±.25	



† All marks shown within this document are properties of their respective owners.

DIMENSIONS

TEFC

HOLLOSHAFT®

FRAME: 6812VP, VPA, VPB

TYPES: JU

PRINTS
6812
JU

Typical Dimensions For Reference Only

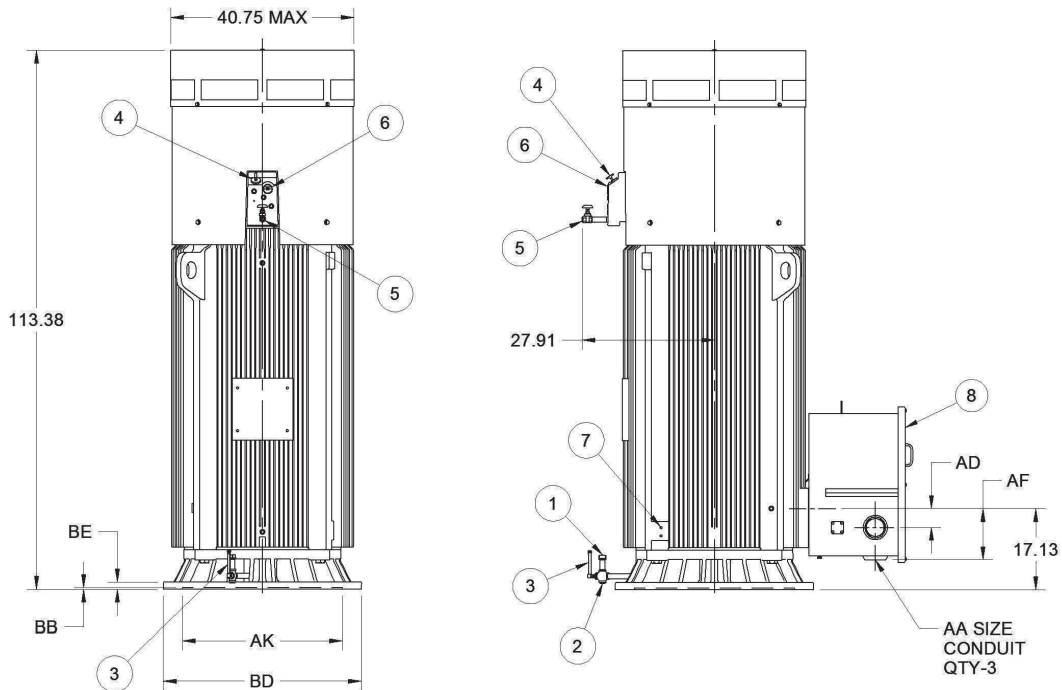

ALL DIMENSIONS ARE IN INCHES

AA
2 NPT
2 1/2 NPT
3 NPT
3 1/2 NPT
4 NPT

C/BOX VOLUME (CU. IN.)	AB	AC	AD	AF
16.200	40.13	33.94	4.00	10.81

FRAME	AJ	AK	BB MIN	BD MAX	BE	BF
6812VP	26.00	22.000	.31	30.50	1.50	.813
6812VPA	32.00	26.000		36.00		1.000
6812VPB	39.00	33.750		42.00		1.125

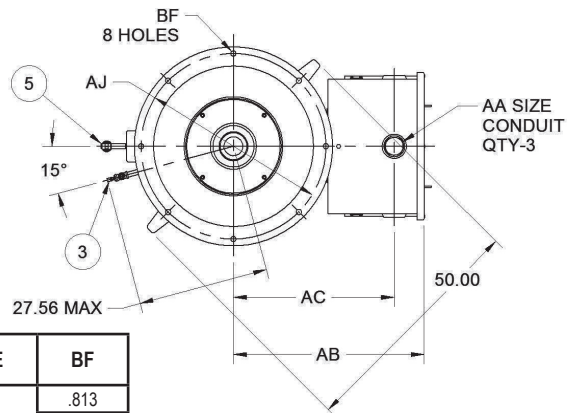

FEATURE LISTING

1	LOWER SUMP OIL FILL	6	UPPER SUMP SIGHT WINDOW		
2	LOWER SUMP OIL DRAIN	7	GRD PADS, DIAG OPP, .50-13		
3	LOWER SUMP SIGHT WINDOW	8	MAIN CONDUIT BOX		
4	UPPER SUMP OIL FILL				
5	UPPER SUMP OIL DRAIN				

TOLERANCES	22.000 AK	26.000 AK 33.750 AK
FACE RUNOUT	.007T.I.R.	.009 T.I.R.
PERMISSIBLE ECCENTRICITY OF MOUNTING RABBET	.007T.I.R.	.009 T.I.R.
MAXIMUM SHAFT END PLAY	.010	.010
TOLERANCE ON AK-DIMENSION	+.005	+.007
NON-MACHINED DIMENSIONS MAY VARY BY ±.25		



DIMENSIONS
WEATHER PROTECTED I
SOLID SHAFT
FRAME: 182HP - 286HPHZ

TYPES: AV, AVE & AVI

PRINTS
182 - 286
AV, AVE & AVI

Typical Dimensions For Reference Only

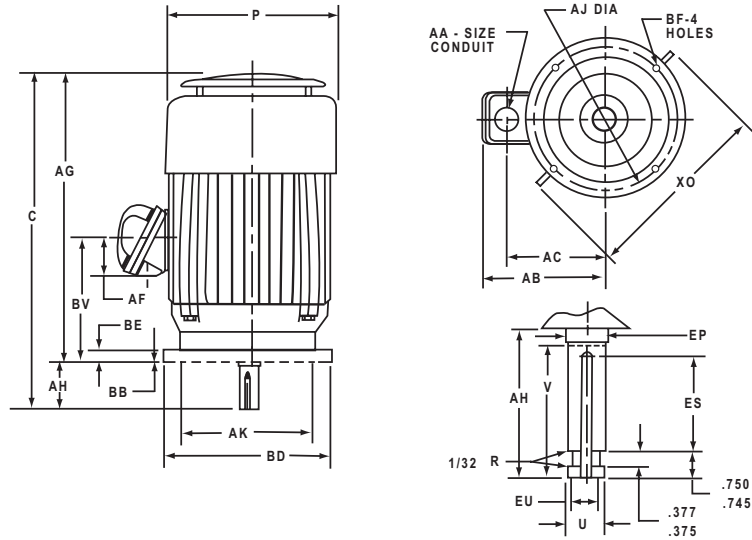

ALL DIMENSIONS ARE IN INCHES

BASIC FRAME	P ³	AA	AB	AC	AF	AG	BE	BV	XO
182, 184	9.5	1	6.937	5.375	2.625	15.25	0.812	6.5	11.187
213, 215	11.125	1	7.5	6.61	3.19	19.093	0.75	8	12.75
254, 256	14	1.25	10.25	7.88	2.03	20.312	0.937	12.75	16.875
284, 286	14	1.5	11.07	8.32	2.562	21.687	1	14.75	16.875

FRAME	C	U ²	V MIN	AH ±.031	AJ	AK	BB MIN	BD	BF	EP MIN	ES MIN	EU -.005	SQ KEY
182, 184HP	18	1.125	2.75	2.75	9.125	8.25	0.187	10	0.437	1.156	1.312	0.875	0.25
213, 215HP	21.843	1.125	2.75	2.75	9.125	8.25	0.187	10	0.437	1.375	1.312	0.875	0.25
254, 256HP	22.00	1.125	2.75	2.75	9.125	8.25	0.187	10	0.437	1.75	1.312	0.875	0.25
284, 286HP	24.50	1.125	2.75	2.75	9.125	8.25	0.187	10	0.437	1.75	1.312	0.875	0.25
284, 286HPA	24.50	1.125	2.75	2.75	9.125	8.25	0.187	12	0.437	1.75	1.312	0.875	0.25
284, 286HPH	24.50	1.625	4.5	4.5	14.75	13.5	0.25	16.5	0.687	1.75	1.312	1.75	0.25

- 1: ALL ROUGH CASTING DIMENSIONS MAY VARY BY .25" DUE TO CASTING VARIATIONS.
- 2: SHAFT EXTENSIONS DIAMETER TOLERANCE: +.0000: -.0005 UP 1 -1/2" INCLUSIVE. LARGE DIAMETERS: +.000; -.001
- 3: LONGEST MOTOR WIDTH.
- 4: CONDUIT OPENING MAY BE LOCATED IN STEPS OF 90 DEGREES STANDARD AS SHOWN WITH CONDUIT OPENING DOWN.

TOLERANCES	8.25 AK	13.5 AK
"AK" DIMENSION	.004; -.000	.006; -.000
FACE RUNOUT	.004 T.I.R.	.006 T.I.R.
PERMISSIBLE ECCENTRICITY OF MOUNTING RABBET	.004 T.I.R.	.006 T.I.R.
PERMISSIBLE SHAFT RUNOUT	.002 T.I.R.	.002 T.I.R.

† All marks shown within this document are properties of their respective owners.



DIMENSIONS
WEATHER PROTECTED I
SOLID SHAFT
FRAME: 182VP - 286VPHZ

TYPES: AV, AVE & AVI



Typical Dimensions For Reference Only

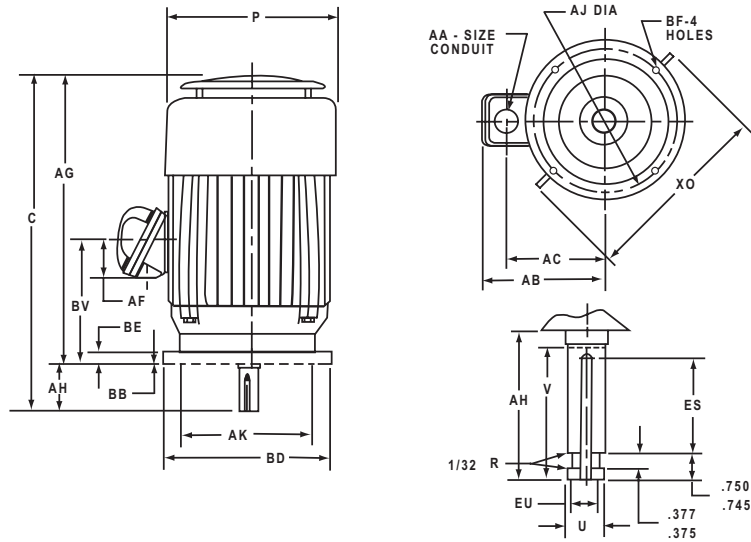

ALL DIMENSIONS ARE IN INCHES

BASIC FRAME	P ³	AA	AB	AC	AF	AG	BE	BV	XO
182, 184	9.5	1	6.937	5.375	2.625	15.25	0.812	6.5	11.187
213, 215	11.125	1	7.86	6.61	3.19	19.093	0.75	8	12.75
254, 256	13.38	1.25	10.25	7.88	2.03	20.312	0.937	12.75	16.875
284, 286	14	1.5	11.07	8.32	2.562	21.687	1	14.75	16.875

FRAME	C	U ²	V MIN	AH ±.062	AJ	AK	BB MIN	BD	BF	ES MIN	EU -.005	SQ KEY
182, 184VP	18	1.125	2.75	2.75	9.125	8.25	0.187	10	0.437	1.312	0.875	0.25
213, 215VP	21.843	1.125	2.75	2.75	9.125	8.25	0.187	10	0.437	1.312	0.875	0.25
254, 256VP	22	1.125	2.75	2.75	9.125	8.25	0.187	10	0.437	1.312	0.875	0.25
254, 256VPH	22	1.125	2.75	2.75	9.125	8.25	0.187	12	0.437	1.312	0.875	0.25
284, 286VPZ	26.25	1.625	4.5	4.5	9.125	8.25	0.187	10	0.437	3.062	1.25	0.375
284, 286VPAZ	26.25	1.625	4.5	4.5	9.125	8.25	0.187	12	0.437	3.062	1.25	0.375
284, 286VPHZ	26.25	1.625	4.5	4.5	14.75	13.5	0.25	16.5	0.687	3.062	1.25	0.375
284, 286VP	24.50	1.125	2.75	2.75	9.125	8.25	0.187	10	0.437	1.312	0.875	0.25
284, 286VPA	24.50	1.125	2.75	2.75	9.125	8.25	0.187	12	0.437	1.312	0.875	0.25
284, 286VPH	24.50	1.125	2.75	2.75	14.75	13.5	0.25	16.5	0.687	1.312	0.875	0.25

- 1: ALL ROUGH CASTING DIMENSIONS MAY VARY BY 1/4" DUE TO CASTING VARIATIONS.
- 2: SHAFT EXTENSIONS DIAMETER TOLERANCE: +.0000; -.0005 UP 1 - 1/2" INCLUSIVE. LARGE DIAMETERS: +.000; -.001
- 3: LONGEST MOTOR WIDTH.
- 4: CONDUIT OPENING MAY BE LOCATED IN STEPS OF 90 DEGREES STANDARD AS SHOWN WITH CONDUIT OPENING DOWN.

TOLERANCES	8.25 AK	13.5 AK
"AK" DIMENSION	+.003; -.000	+.005; -.000
FACE RUNOUT	.004 T.I.R.	.007 T.I.R.
PERMISSIBLE ECCENTRICITY OF MOUNTING RABBET	.004 T.I.R.	.007 T.I.R.
PERMISSIBLE SHAFT RUNOUT	.002 T.I.R.	.002 T.I.R.



† All marks shown within this document are properties of their respective owners.

DIMENSIONS
WEATHER PROTECTED I
SOLID SHAFT
FRAME: 324HP - 445HPA

TYPES: RV, RVE, RVI & RVS

PRINTS
324 - 445
RV, RVE
RVI, RVS

Typical Dimensions For Reference Only

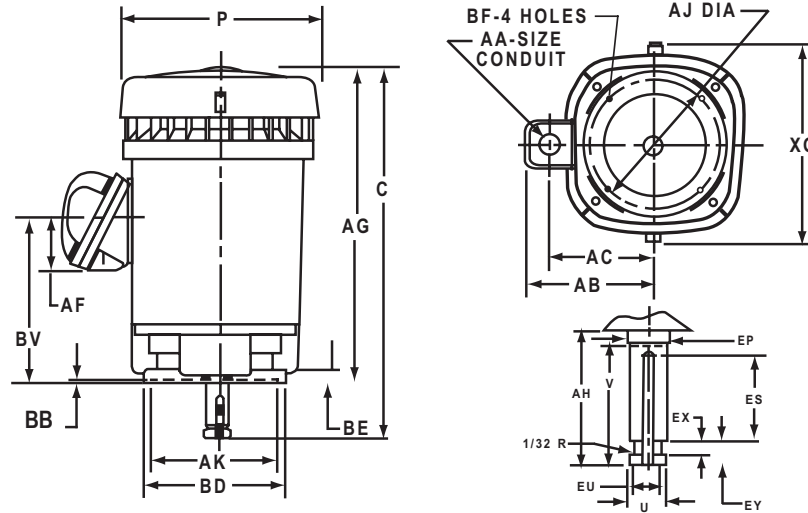

ALL DIMENSIONS ARE IN INCHES

BASIC FRAME	C	P ²	U -.0005	V MIN	AA	AB	AC	AF	AG
324, 326HP	29.437	18.25	1.625	4.5	3	15.75	11.50	3.38	24.937
364, 365HP	32.375	18.25	1.625	4.5	3	15.75	11.50	3.38	27.875
364, 365HPZ	32.375	18.25	2.125	4.5	3	15.75	11.50	3.38	27.875
404, 405HP	36.25	20.5	1.625	4.5	3	16.375	12.63	3.38	31.75
404, 405HPZ	36.25	20.5	2.125	4.5	3	16.375	12.63	3.38	31.75
444, 445HP	41.5	23.125	2.125 ⁴	4.5	3	18.94	14.44	4.72	37

FRAME	AJ	AK	BB MIN	BD	BE	BF
324, 326HP, 364 365HP	14.75	13.5	0.25	16.5	0.687	0.687
364, 365HPA	9.125	8.25	0.187	12	15/16	0.437
404, 405HP	14.75	13.5	0.25	16.5	0.75	0.687
404, 405HPA	14.75	13.5	0.25	20	0.75	0.687
444, 445HP	14.75	13.5	0.25	16.5	0.75	0.687
444, 445HPA	14.75	13.5	0.25	20	0.75	0.687

BASIC FRAME	AH±.031	BV	EP MIN	ES MIN	EU -.005	EX	EY	XO	SQ KEY
324, 326 HP	4.5	12.375	2.125	3.156	1.25	0.375	0.75	20.937	0.375
364, 365 HP	4.5	15.312	2.25	3.156	1.25	0.375	0.75	20.937	0.375
364, 365 HPZ	4.5	15.312	2.25	3.156	1.75	0.375	0.75	20.937	0.5
404, 405 HP	4.5	18.125	2.25	3.156	1.25	0.375	0.75	23.375	0.375
404, 405 HPZ	4.5	18.125	2.25	3.156	1.75	0.375	0.75	23.375	0.5
444, 445 HP	4.5	21.156	2.25	3.156	1.75	0.375	0.75	25.875	0.5

TOLERANCES	8.25 AK	13.50 AK
"AK" DIMENSION	.004; -.000	.006; -.000
FACE RUNOUT	.004 T.I.R.	.006 T.I.R.
PERMISSIBLE ECCENTRICITY OF MOUNTING RABBET	.004 T.I.R.	.006 T.I.R.
PERMISSIBLE SHAFT RUNOUT	.002 T.I.R.	.002 T.I.R.

- 1: ALL ROUGH CASTING DIMENSIONS MAY VARY BY 1/4" DUE TO CASTING VARIATIONS.
- 2: LARGEST MOTOR WIDTH.
- 3: CONDUIT OPENING MAY BE LOCATED IN STEPS OF 90 DEGREES. STANDARD AS SHOWN WITH CONDUIT OPENING DOWN.
- 4: THIS "U" DIMENSION HAS A TOLERANCE OF -.001

† All marks shown within this document are properties of their respective owners.



DIMENSIONS
WEATHER PROTECTED I
SOLID SHAFT
FRAME: 324VP - 445VPA

TYPES: RV, RVE, RVI & RVS

PRINTS
324-445
RV, RVE
RVI, RVS

Typical Dimensions For Reference Only

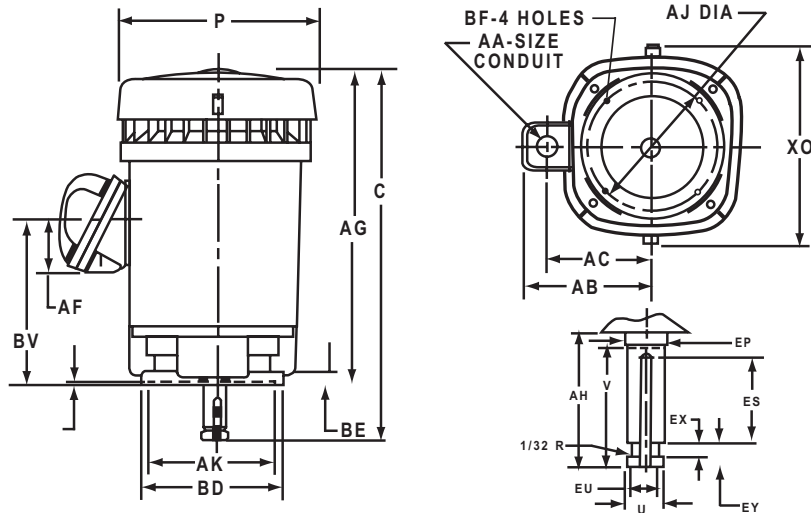

ALL DIMENSIONS ARE IN INCHES

BASIC FRAME	C	P ²	U -.001	V MIN	AA	AB	AC	AF	AG
324, 326VP	29.437	18.25	1.625	4.5	3	15.187	11.625	4	24.937
364, 365VP	32.375	18.25	1.625	4.5	3	15.187	11.625	4	27.875
364, 365VPZ	32.375	18.25	2.125	4.5	3	15.75	11.625	4	27.875
404, 405VP	36.25	20.5	1.625	4.5	3	16.375	12.75	4	31.75
404, 405VPZ	36.25	20.5	2.125	4.5	3	16.375	12.75	4	31.75
444, 445VP	41.5	23.125	2.125	4.5	3	18.125	13.875	4.875	37

FRAME	AJ	AK	BB MIN	BD	BE	BF
324, 326HP, 364, 365VP, 364, 365VPZ	14.75	13.5	0.25	16.5	0.687	0.687
324, 326VPH, 364, 365VPA, 364, 365VPAZ	9.125	8.25	0.187	12	0.937	0.437
404, 405VP, 404, 405VPZ	14.75	13.5	0.25	16.5	0.75	0.687
404, 405VPA, 404, 405VPAZ	14.75	13.5	0.25	20	0.75	0.687
444, 445VP	14.75	13.5	0.25	16.5	0.75	0.687
444, 445VPA	14.75	13.5	0.25	20	0.75	0.687

BASIC FRAME	AH±.062	BV	ES MIN	EU -.005	EX	EY	XO	SQ KEY
324, 326VP	4.5	12.375	3.156	1.25	0.375	0.75	20.937	0.375
364, 365VP	4.5	15.312	3.156	1.25	0.375	0.75	20.937	0.375
364, 365VPZ	4.5	15.312	3.156	1.75	0.375	0.75	20.937	0.5
404, 405VP	4.5	18.125	3.156	1.25	0.375	0.75	23.375	0.375
404, 405VPZ	4.5	18.125	3.156	1.75	0.375	0.75	23.375	0.5
444, 445VP	4.5	21.156	3.156	1.75	0.375	0.75	25.875	0.5

TOLERANCES	8.25 AK	13.50 AK
"AK" DIMENSION	.004; -.000	.006; -.000
FACE RUNOUT	.004 T.I.R.	.007 T.I.R.
PERMISSIBLE ECCENTRICITY OF MOUNTING RABBET	.004 T.I.R.	.007 T.I.R.
PERMISSIBLE SHAFT RUNOUT	.002 T.I.R.	.002 T.I.R.

- 1: ALL ROUGH CASTING DIMENSIONS MAY VARY BY .25" DUE TO CASTING VARIATIONS.
- 2: LARGEST MOTOR WIDTH.
- 3: CONDUIT OPENING MAY BE LOCATED IN STEPS OF 90 DEGREES. STANDARD AS SHOWN WITH CONDUIT OPENING DOWN.

† All marks shown within this document are properties of their respective owners.



DIMENSIONS
WEATHER PROTECTED I
SOLID SHAFT
FRAME: 447HP

TYPES: RV & RVS

PRINTS
447
RV, RVS

Typical Dimensions For Reference Only

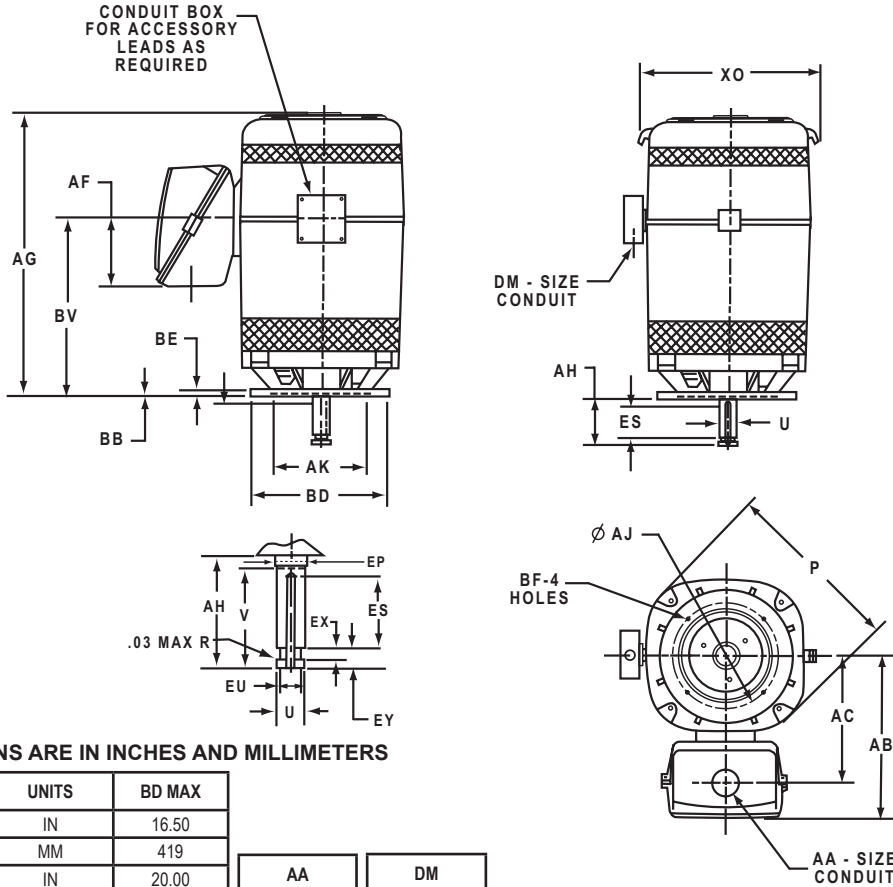

ALL DIMENSIONS ARE IN INCHES AND MILLIMETERS

FRAME	UNITS	BD MAX	AA	DM
447HP	IN	16.50		
	MM	419		
447HPA	IN	20.00		
	MM	508		
447HP	IN	24.50	3 NPT	0.75 NPT
			3.5 NPT	1 NPT
	MM	622	4 NPT	1.5 NPT

UNITS	P ²	AB	AC	AF	AG	AJ
IN	26.94	24.25	18.75	10.00	42.00	14.750
MM	684	616	476	254	1067	374.65

UNITS	AK +.005	BB MIN	BE	BF	BV	EW +.002	EW -.005	XO
IN	13.500	.25	1.00	.69	26.19	.375	.750	25.88
MM	342.90	6	25	18	665	9.53	19.05	657

	4 - POLE	6 - POLE	8 - POLE & SLOWER	UNITS	U -.001	AH ±.063	ES MIN	EP MIN	EU -.005	SQ KEY
HP	300 & DOWN	200 & DOWN	ALL	IN	2.125	4.50	3.00	2.25	1.750	.500
				MM	53.98	114.30	76	2.25	44.45	12.70
	350 TO 400	250	---	IN	2.375	5.00	3.50	2.25	2.000	.625
				MM	60.33	127.00	89	2.25	50.80	15.88

- 1: DIMENSIONS MAY VARY .25" DUE TO CASTING AND/OR FABRICATION VARIATIONS.
- 2: LARGEST MOTOR WIDTH.
- 3: TOLERANCES SHOWN ARE IN INCHES ONLY



† All marks shown within this document are properties of their respective owners.

DIMENSIONS
WEATHER PROTECTED I
SOLID SHAFT
FRAME: 447VP

TYPES: RV & RVS

PRINTS
447
RV, RVS

Typical Dimensions For Reference Only

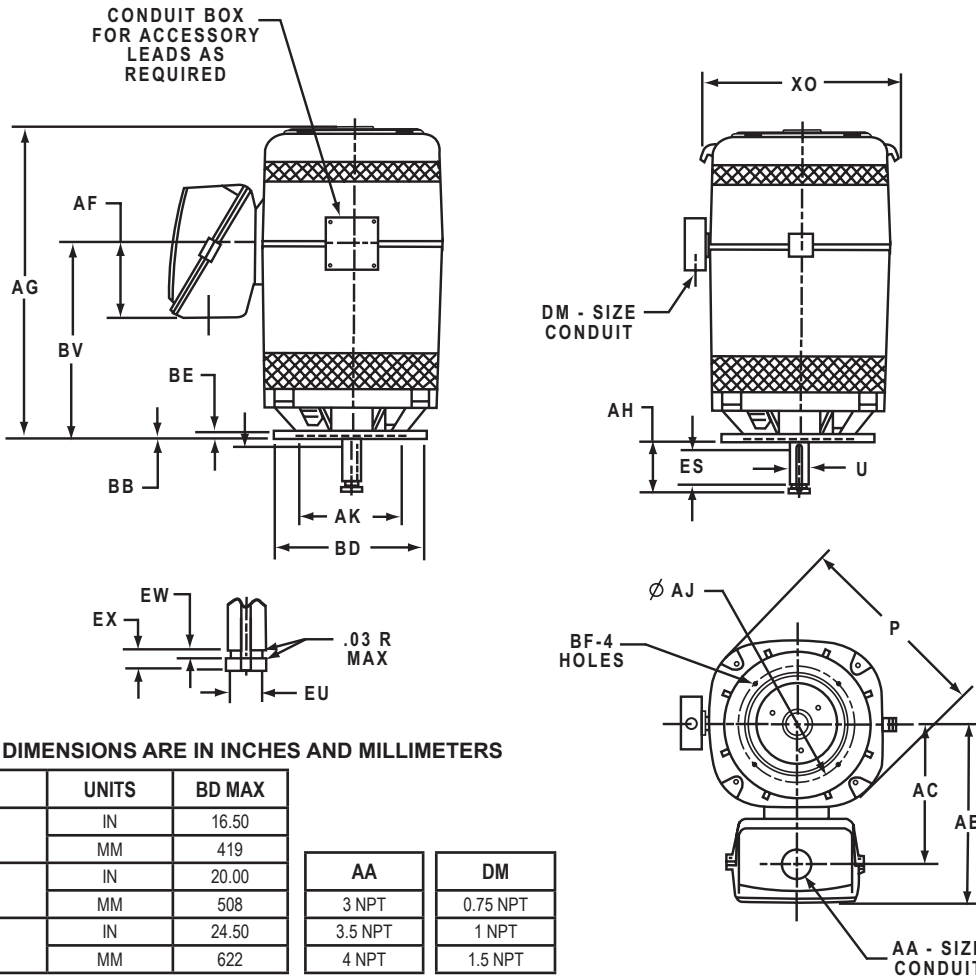

ALL DIMENSIONS ARE IN INCHES AND MILLIMETERS

FRAME	UNITS	BD MAX	AA	DM
447VP	IN	16.50	3 NPT	0.75 NPT
	MM	419		
447VPA	IN	20.00	3.5 NPT	1 NPT
	MM	508		
447VP	IN	24.50	4 NPT	1.5 NPT
	MM	622		

UNITS	P ²	AB	AC	AF	AG	AJ
IN	26.94	24.25	18.75	10.00	42.00	14.750
MM	684	616	476	254	1067	374.65

UNITS	AK +.005	BB MIN	BE	BF	BV	EW +.002	EW -.005	XO
IN	13.500	.25	1.00	.69	26.19	.375	.750	25.88
MM	342.90	6	25	18	665	9.53	19.05	657

	4 - POLE	6 - POLE	8 - POLE & SLOWER	UNITS	U -.001	AH ±.063	ES MIN	EU -.005	SQ KEY
HP	300 & DOWN	200 & DOWN	ALL	IN	2.125	4.50	3.00	1.750	.500
				MM	53.98	114.30	76	44.45	12.70
	350 TO 400	250	---	IN	2.375	5.00	3.50	2.000	.625
				MM	60.33	127.00	89	50.80	15.88

- 1: DIMENSIONS MAY VARY .25" DUE TO CASTING AND/OR FABRICATION VARIATIONS.
- 2: LARGEST MOTOR WIDTH.
- 3: TOLERANCES SHOWN ARE IN INCHES ONLY.



† All marks shown within this document are properties of their respective owners.

DIMENSIONS
WEATHER PROTECTED I
SOLID SHAFT
FRAME: 5000VP

TYPES: RV & RVE

PRINTS
5000
RV, RVE

Typical Dimensions For Reference Only

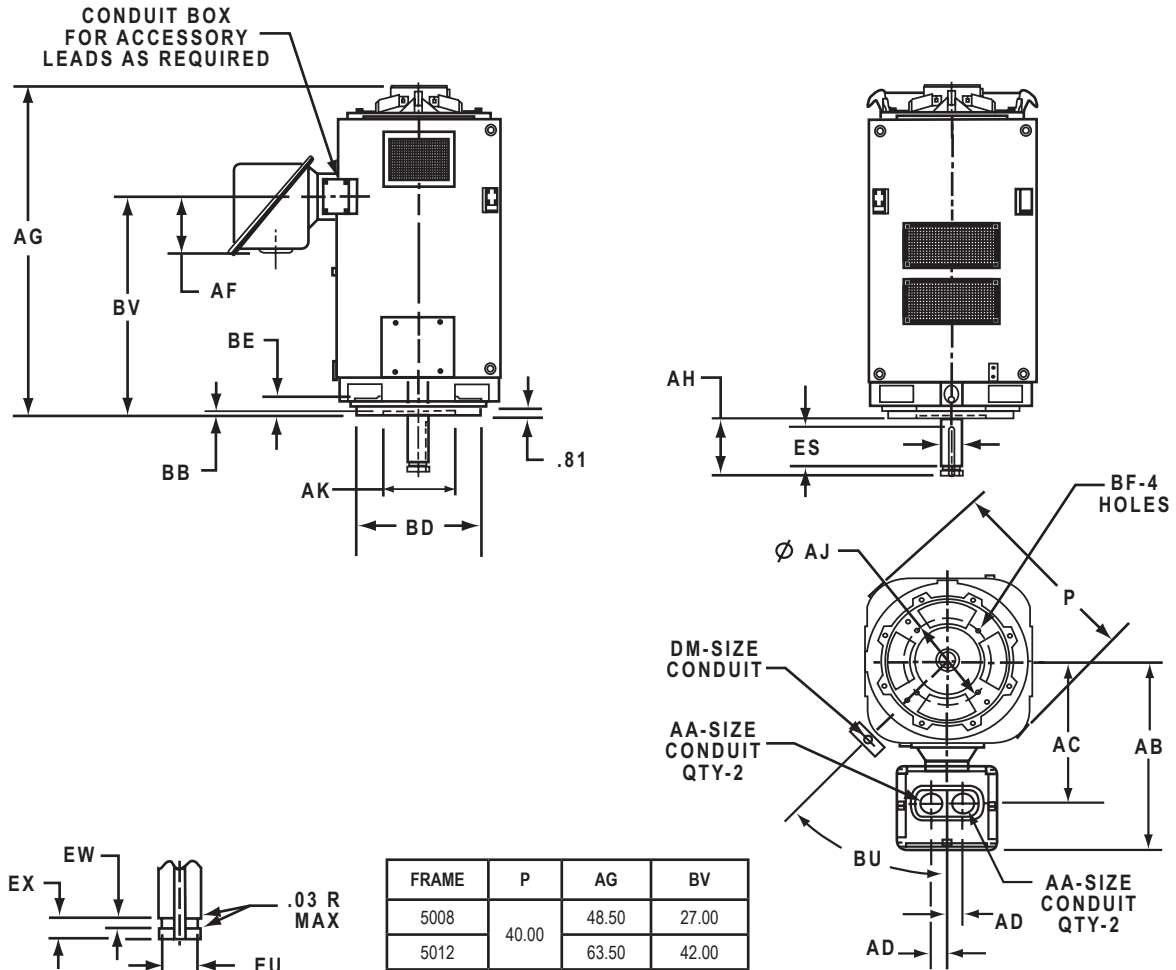

FRAME	P	AG	BV
5008	40.00	48.50	27.00
5012		63.50	42.00

POLE	U -.001	AH ±.062	ES MIN	EU -.005	EW +.002	EW -.005	SQ KEY
2	2.375	5.000	3.50	2.000	.375	.750	.625
4 & SLOWER	3.125	7.000	5.00	2.625	.500	1.000	.750

AA	DM
2 NPT	0.5 NPT
2.5 NPT	0.75 NPT
3 NPT	1 NPT
3.5 NPT	1.25 NPT
4 NPT	1.5 NPT

TOLERANCES	
FACE RUNOUT	.007 T.I.R.
PERMISSIBLE ECCENTRICITY OF MOUNTING RABBET	.007 T.I.R.
PERMISSIBLE SHAFT RUNOUT	.003 T.I.R.
MAXIMUM SHAFT END PLAY	.010

VOLTS	C/BOX VOLUME (CU. IN.)	AB	AC	AD	AF	BU
0-4800	3400	36.50	27.88	3.00	10.94	45°
4801-6900	5600	36.13	30.13	4.00	10.81	

FRAME	AJ	AK +.005	BB MIN	BD MAX	BE	BF
5000VPH	14.750	13.500	.25	20.00	2.19	.69
5000VP3	14.750	13.500		24.50		.69
	22.000			.94		
5000VPA	26.000	22.00	30.50	.81		

1: DIMENSIONS MAY VARY .25" DUE TO CASTING AND/OR FABRICATION VARIATIONS.
 2: DIMENSIONS AND TOLERANCES ARE SHOWN IN INCHES.
 3: 5000VP HAS TWO BOLT CIRCLES.

† All marks shown within this document are properties of their respective owners.



DIMENSIONS
WEATHER PROTECTED I
SOLID SHAFT
FRAME: 6800PA

TYPES: HV & HVE

PRINTS
6800
HV, HVE

Typical Dimensions For Reference Only

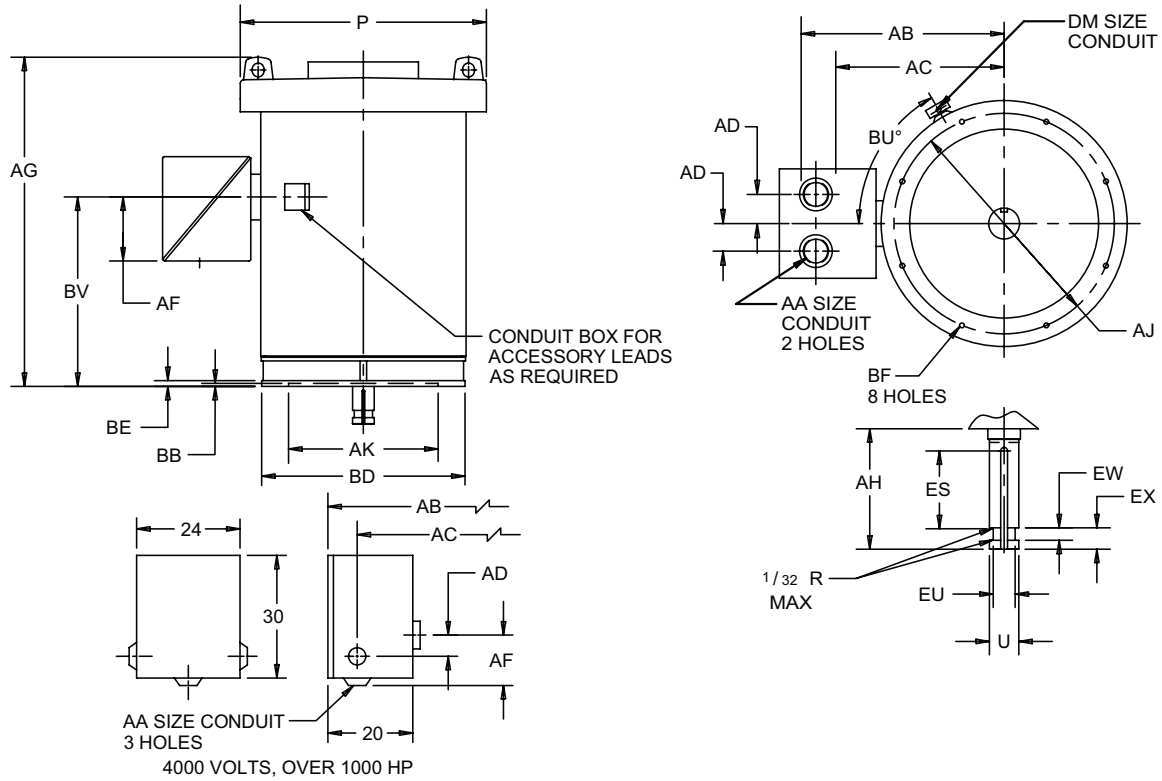

ALL DIMENSIONS ARE IN INCHES

FRAME	P	AG	BV
6808	45.375	62.625	37.25
6810		73.625	48.25

FRAME	BD	BE	AJ	BF	AK +.007	BB	U -.001	AH +.062	ES MIN	EU -.005	EX -.005	EW +.002	SQ KEY
6800PA	36	1.5	32	1	26.000	0.25	3.875	7.500	5.500	3.375	1.000	.500	1

FRAME	HP	VOLT	AA	AB	AC	AD	AF	D°	DM
6800	ALL	460	3.5	35.94	27.312	3	10.937	60	0.75
	ALL	2300							
	THRU 1000	4000		40.8125	34.812	11	17.937		
	1001 & UP	4000							

TOLERANCES	
FACE RUNOUT	.009 F.I.R
PERMISSIBLE ECCENTRICITY OF MOUNTING RABBET	.009 F.I.R
PERMISSIBLE SHAFT RUNOUT	.003 T.I.R.
MAXIMUM SHAFT END PLAY	.010

1: ROUGH DIMENSIONS MAY VARY BY ±.25" DUE TO CASTING AND/OR FABRICATION VARIATIONS.



† All marks shown within this document are properties of their respective owners.

DIMENSIONS
WEATHER PROTECTED I
HOLLOSHAFT®
FRAME: 6813P, PA, PB

TYPES: RV & RVE

PRINTS
449
RV & RVE

Typical Dimensions For Reference Only

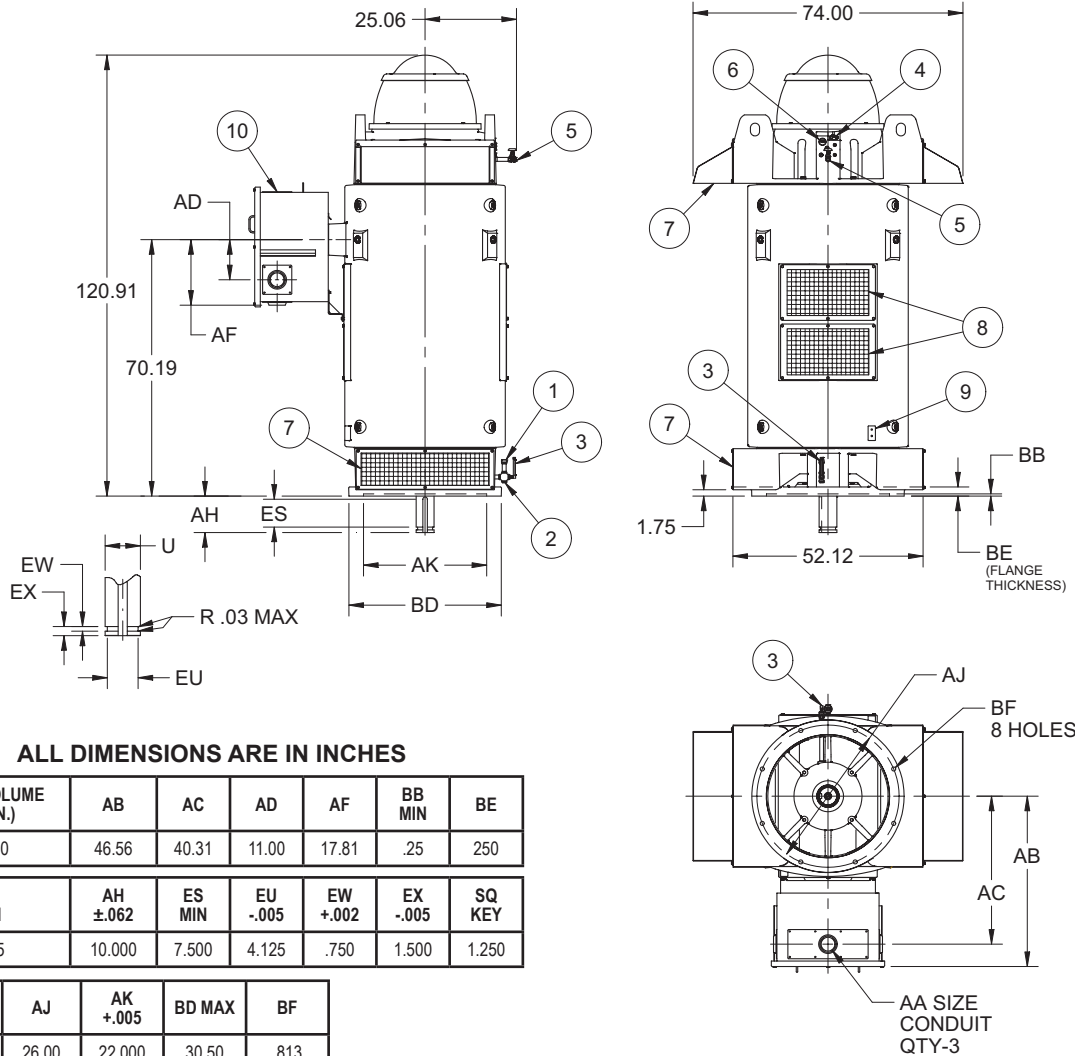

ALL DIMENSIONS ARE IN INCHES

C/BOX VOLUME (CU. IN.)	AB	AC	AD	AF	BB MIN	BE
16,200	46.56	40.31	11.00	17.81	.25	250

U -.001	AH ±.062	ES MIN	EU -.005	EW +.002	EX -.005	SQ KEY
4.875	10.000	7.500	4.125	.750	1.500	1.250

FRAME	AJ	AK +.005	BD MAX	BF
6813P	26.00	22.000	30.50	.813
6813PA	32.00	26.000	36.00	.813
6813PB	39.00	33.750	42.00	1.250

FEATURE LISTING

1	LOWER SUMP OIL FILL	6	UPPER SUMP SIGHT WINDOW
2	LOWER SUMP OIL DRAIN	7	AIR INTAKE, 180° APART
3	LOWER SUMP SIGHT WINDOW	8	AIR EXHAUST, 180° APART
4	UPPER SUMP OIL FILL	9	GRD PADS, DIAG OPP, 1/2-13
5	UPPER SUMP OIL DRAIN	10	MAIN CONDUIT BOX

- 1: ALL ROUGH CASTING DIMENSIONS MAY VARY BY .25" DUE TO CASTING VARIATIONS.
- 2: LARGEST MOTOR WIDTH.
- 3: CONDUIT OPENING MAY BE LOCATED IN STEPS OF 90°. STANDARD AS SHOWN WITH CONDUIT OPENING DOWN.

TOLERANCES	
FACE RUNOUT	.009 T.I.R.
PERMISSIBLE ECCENTRICITY OF MOUNTING RABBET	.009 T.I.R.
PERMISSIBLE SHAFT RUNOUT	.003 T.I.R.
MAXIMUM SHAFT END PLAY	.010
NON-MACHINED DIMENSIONS MAY VARY BY ±.25	



† All marks shown within this document are properties of their respective owners.

DIMENSIONS
WEATHER PROTECTED I
SOLID SHAFT
FRAME: 8000PH

TYPES: RV & RVE

PRINTS
8000
RV, RVE

Typical Dimensions For Reference Only

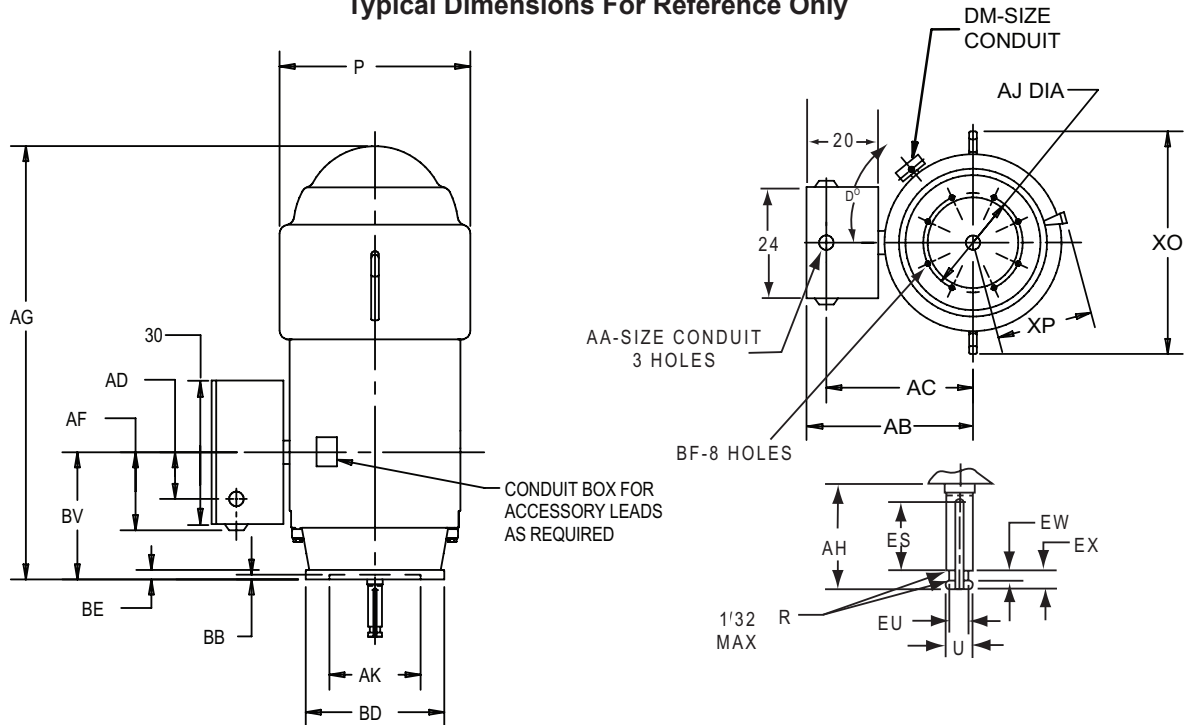

ALL DIMENSIONS ARE IN INCHES

FRAME	XP	XO	P	AG	BV
8006	25	48.25	45	92.062	33.75
8007				96.062	37.75
8008				100.062	41.75
8009				104.062	45.75
8010				108.062	49.75
8011				112.062	53.75

U -.001	AH ± .062	ES MIN	EU -.005	EX -.005	EW +.002	SQ KEY
4.875	10.000	7.500	4.125	1.500	.750	1.25

FRAME	BD	BE	AJ	BF	AK +.007	BB
8000PH	42	1.75	39	1.125	33.750	0.25

FRAME	HP	VOLT	AA	AB	AC	AD	AF	D°	DM
8000	ALL	ALL	3.5	43.437	37.437	11	17.937	45	1

TOLERANCES	
FACE RUNOUT	.009 T.I.R.
PERMISSIBLE ECCENTRICITY OF MOUNTING RABBET	.007 T.I.R.
PERMISSIBLE SHAFT RUNOUT	.003 T.I.R.
MAXIMUM SHAFT END PLAY	.010

1: ROUGH DIMENSIONS MAY VARY BY ±1/4" DUE TO CASTING AND OR FABRICATION VARIATIONS.

† All marks shown within this document are properties of their respective owners.



DIMENSIONS
WEATHER PROTECTED I
SOLID SHAFT
FRAME: 182VP - 286VPHZ

TYPES: AV-4, AVE-4 & AVI-4

PRINTS
182-286
AV-4, AVE-4,
AVI-4

Typical Dimensions For Reference Only

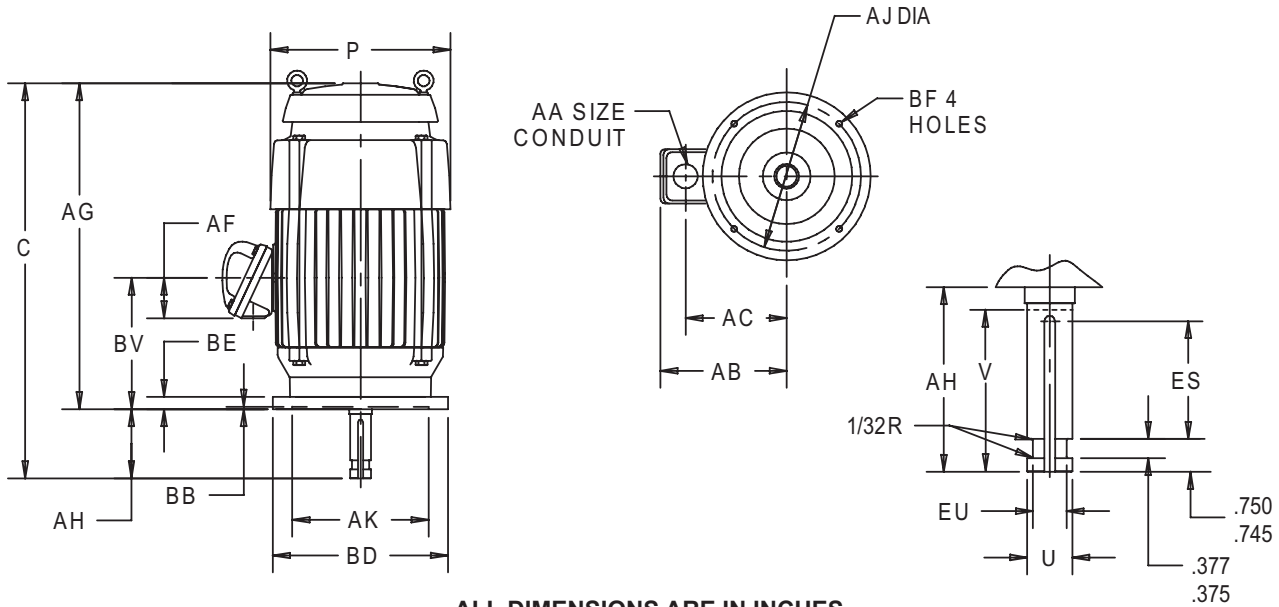

ALL DIMENSIONS ARE IN INCHES

FRAME	C	U ²	V MIN	AH ± .062	AJ	AK	BB MIN	BD	BF	ES MIN	EU -.005	SQ KEY
182, 184VP	18	1.125	2.75	2.75	9.125	8.25	0.187	10	0.437	1.25	0.875	0.25
213, 215VP	21.84	1.125	2.75	2.75	9.125	8.25	0.187	10	0.437	1.25	0.875	0.25
254, 256VP	22	1.125	2.75	2.75	9.125	8.25	0.25	10	0.437	1.875	0.875	0.25
254, 256VPH		1.125	2.75	2.75	9.125	8.25	0.25	12	0.437	1.875	0.875	0.25
284, 286VP	31	1.125	2.75	2.75	9.125	8.25	0.187	10	0.437	1.312	0.875	0.25
284, 286VPA		1.125	2.75	2.75	9.125	8.25	0.187	12	0.437	1.312	0.875	0.25
284, 286VPH		1.125	2.75	2.75	14.75	13.5	0.25	16.5	0.687	1.312	0.875	0.25
284, 286VPZ	32.75	1.625	4.5	4.5	9.125	8.25	0.187	10	0.437	3.062	1.25	0.375
284, 286PAZ		1.625	4.5	4.5	9.125	8.25	0.187	12	0.437	3.062	1.25	0.375
284, 286VPHZ		1.625	4.5	4.5	14.75	13.5	0.25	16.5	0.687	3.062	1.25	0.375

BASIC FRAME	P ⁴	AA	AB	AC	AF	AG	BE	BV	XO	TOLERANCES		
										8.25 AK	13.5 AK	
182, 184	9.5	1	7.30	6.14	2.625	15.25	0.812	6.5	11.187	FACE RUNOUT	.004 F.I.R.	.007 T.I.R.
213, 215	11.125	1	7.86	6.61	3.19	19.093	0.75	8	12.75	PERMISSIBLE ECCENTRICITY OF MOUNTING RABBET	.004 F.I.R.	.007 T.I.R.
254, 256	14	1.25	8.937	7.75	3.593	20.312	0.937	11.437	16.875	PERMISSIBLE SHAFT RUNOUT	.002 T.I.R.	.002 T.I.R.
284, 286	14	1.25	11.07	8.32	2.562	28.062	1	14.75	16.875	"AK" DIMENSION	+.003; -.000	+.005; -.000

- 1: ALL ROUGH CASTING DIMENSIONS MAY VARY BY ± 1/4" DUE TO CASTING VARIATIONS.
- 2: SHAFT EXTENSION DIAMETER TOLERANCE: +.0000; -.0005 UP 1-1/2" INCLUSIVE.
 LARGE DIAMETERS: +.000; -.001
- 3: CONDUIT OPENING MAY BE LOCATED IN STEPS OF 90°.
- 4: LARGEST MOTOR WIDTH.

† All marks shown within this document are properties of their respective owners.



DIMENSIONS
WEATHER PROTECTED I
SOLID SHAFT
FRAME: 324VP - 445VPA

TYPES: RV-4, RVE-4, RVI-4 & RVS-4

PRINTS
324-445
RV-4, RVE-4,
RVI-4, RVS-4

Typical Dimensions For Reference Only

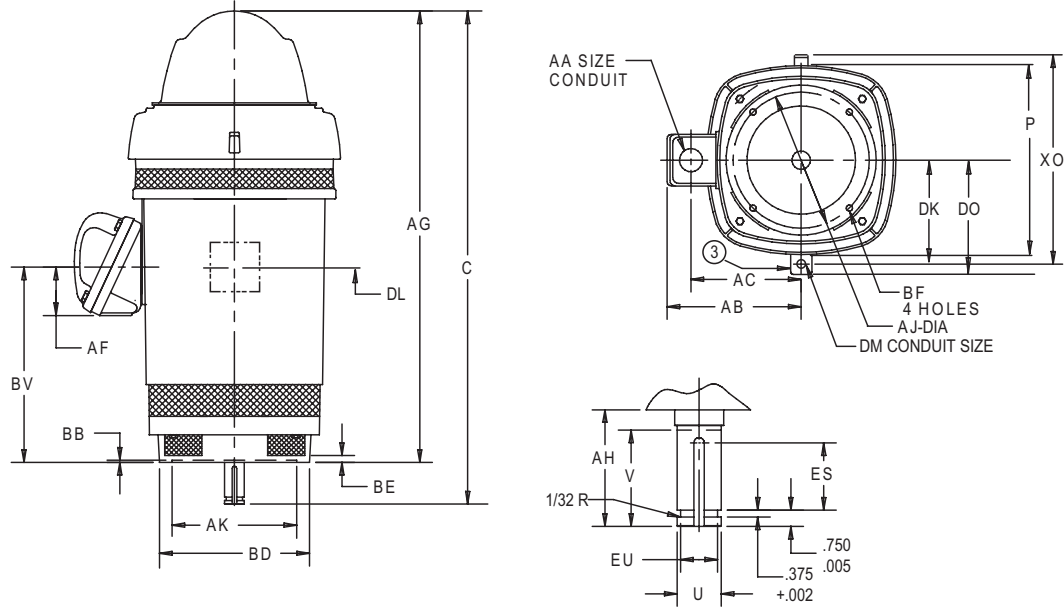

ALL DIMENSIONS ARE IN INCHES

BASIC FRAME	C	P ²	V MIN	AA	AB	AC	AF	AG	BASIC FRAME	AH	BE	BV	DK	DL	DM	DQ	XO
320	37.125	18.375	4.5	3	15.75	11.5	3.375	32.625	320	4.5	0.687	11.062	9.937	3.375	1	11.375	21
360	40.062	18.375	4.5	3	15.75	11.5	3.375	35.562	360	4.5	0.687	14	9.937	3.375	1	11.375	21
400	47.187	23.25	4.5	3	16.875	12.625	3.375	42.687	400	4.5	0.75	18.125	10.875	3.375	1	12.312	24.125
H440	52.875	22.88	4.5	3	18.818	14.38	4.727	47.81	440	4.5	0.75	21.187	11.875	3.375	1	13.312	27.5

FRAME	U	AJ	AK	BB MIN	BD	BF	ES MIN	EU -.005	SQ KEY
324, 326VP	1.625	14.75	13.5	0.25	16.5	0.687	3.156	1.25	0.375
324, 326VPH		9.125	8.25	0.187	12	0.437	3.156	1.25	0.375
364, 365VP	1.625	14.75	13.5	0.25	16.5	0.687	3.156	1.25	0.375
364, 365VPA		9.125	8.25	0.187	12	0.437	3.156	1.25	0.375
364, 365VPZ	2.125	14.75	13.5	0.25	16.5	0.687	3.093	1.75	0.5
364, 365VPAZ		9.125	8.25	0.187	12	0.437	3.093	1.75	0.5
404, 405VP	1.625	14.75	13.5	0.25	16.5	0.687	3.031	1.25	0.375
404, 405VPA		14.75	13.5	0.25	20	0.687	3.031	1.25	0.375
404, 405VPZ	2.125	14.75	13.5	0.25	16.5	0.687	3.031	1.75	0.5
404, 405VPAZ		14.75	13.5	0.25	20	0.687	3.031	1.75	0.5
H444, H445VP	2.125	14.75	13.5	0.25	16.5	0.687	3.031	1.75	0.5
H444, H445VPA		14.75	13.5	0.25	20	0.687	3.031	1.75	0.5

TOLERANCES	8.25 AK	13.50 AK
"AK" DIMENSION	+ .003	.005 T.I.R.
FACE RUNOUT	.004 F.I.R.	.007 T.I.R.
PERMISSIBLE ECCENTRICITY OF MOUNTING RABBET	.004 T.I.R.	.007 T.I.R.
PERMISSIBLE SHAFT RUNOUT	.002 T.I.R.	.002 T.I.R.

- 1: ALL ROUGH CASTING DIMENSIONS MAY VARY BY .25" DUE TO CASTING VARIATIONS.
- 2: LARGEST MOTOR WIDTH.
- 3: SEPARATE OUTLET BOX CONTAINS WINDING RTD. AND SPACE HEATERS LEADS.
- 4: CONDUIT OPENING MAY BE LOCATED IN STEPS OF 90°. STANDARD AS SHOWN WITH CONDUIT OPENING DOWN.



† All marks shown within this document are properties of their respective owners.

DIMENSIONS
WEATHER PROTECTED I
SOLID SHAFT
FRAME: 447VP, VPA, VPB

TYPES: RV-4 & RVS-4

PRINTS
447
RV-4, RVS-4

Typical Dimensions For Reference Only

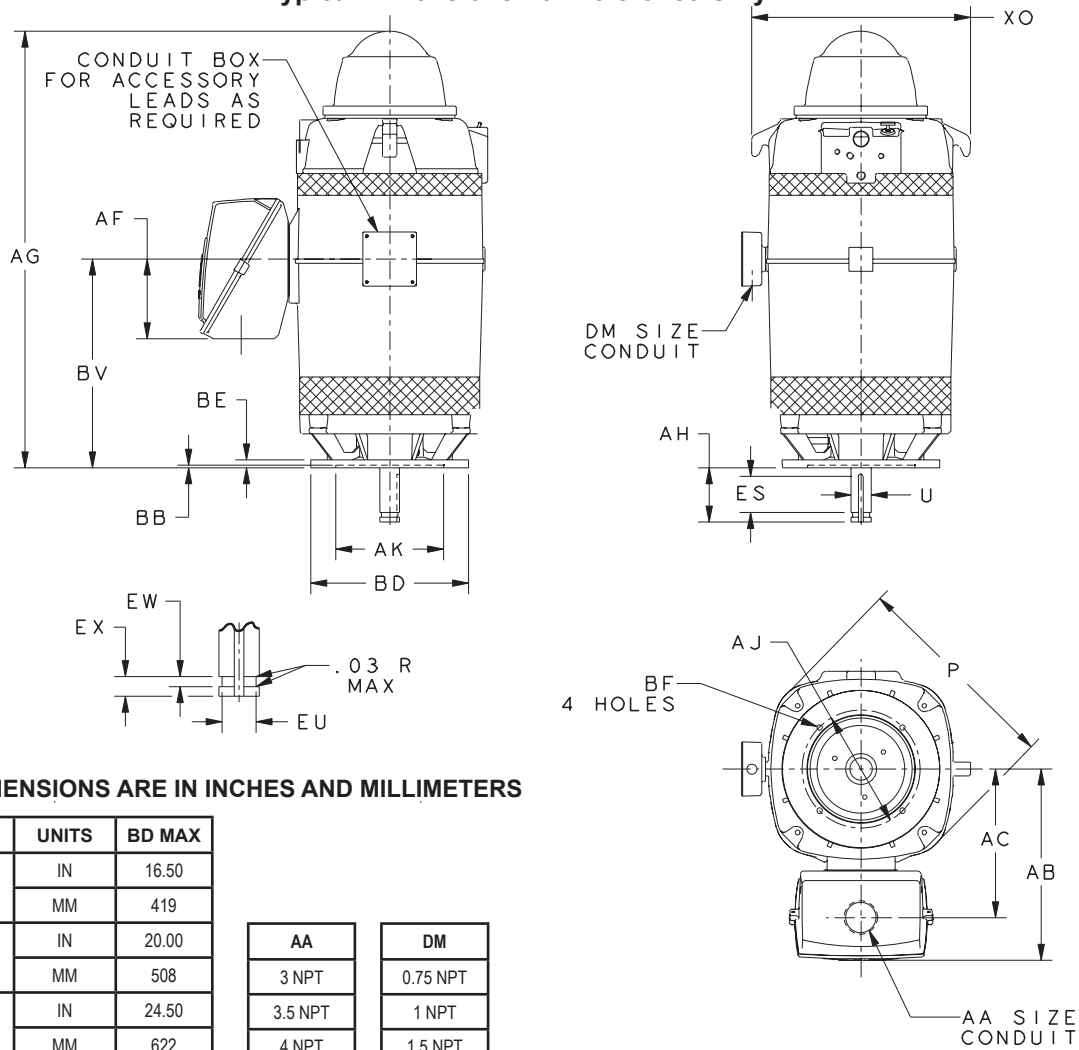

ALL DIMENSIONS ARE IN INCHES AND MILLIMETERS

FRAME	UNITS	BD MAX
447VP	IN	16.50
	MM	419
447VPA	IN	20.00
	MM	508
447VPB	IN	24.50
	MM	622

AA	DM
3 NPT	0.75 NPT
3.5 NPT	1 NPT
4 NPT	1.5 NPT

UNITS	P ²	AB	AC	AF	AG	AJ
IN	26.94	24.25	18.75	10.00	55.00	14.750
MM	684	616	476	254	1397	374.65

UNITS	AK +.005	BB MIN	BE	BF	BV	EW +.002	EX -.005	XO
IN	13.500	.25	1.00	.69	26.19	.375	.750	27.50
MM	342.90	6	25	18	665	9.53	19.05	699

HP	4-POLE	6-POLE	8-POLE & SLOWER	UNITS	U -.001	AH ±.063	ES MIN	EU -.005	SQ KEY
	300 & DOWN	200 & DOWN	ALL	IN	2.125	4.50	3.00	1.750	.500
			MM	53.98	114.30	76	44.45	12.70	
350 TO 400	250	---	IN	2.375	5.00	3.50	2.000	.625	
			MM	60.33	127.00	89	50.80	15.88	

- 1: DIMENSIONS MAY VARY BY .25" DUE TO CASTING AND/OR FABRICATION VARIATIONS.
- 2: LARGEST MOTOR WIDTH.
- 3: TOLERANCES SHOWN ARE IN INCHES ONLY.



† All marks shown within this document are properties of their respective owners.

DIMENSIONS
WEATHER PROTECTED I
HOLLOSHAFT®
FRAME: 449VPH, VP, VPA

TYPES: RV-4 & RVS4



Typical Dimensions For Reference Only

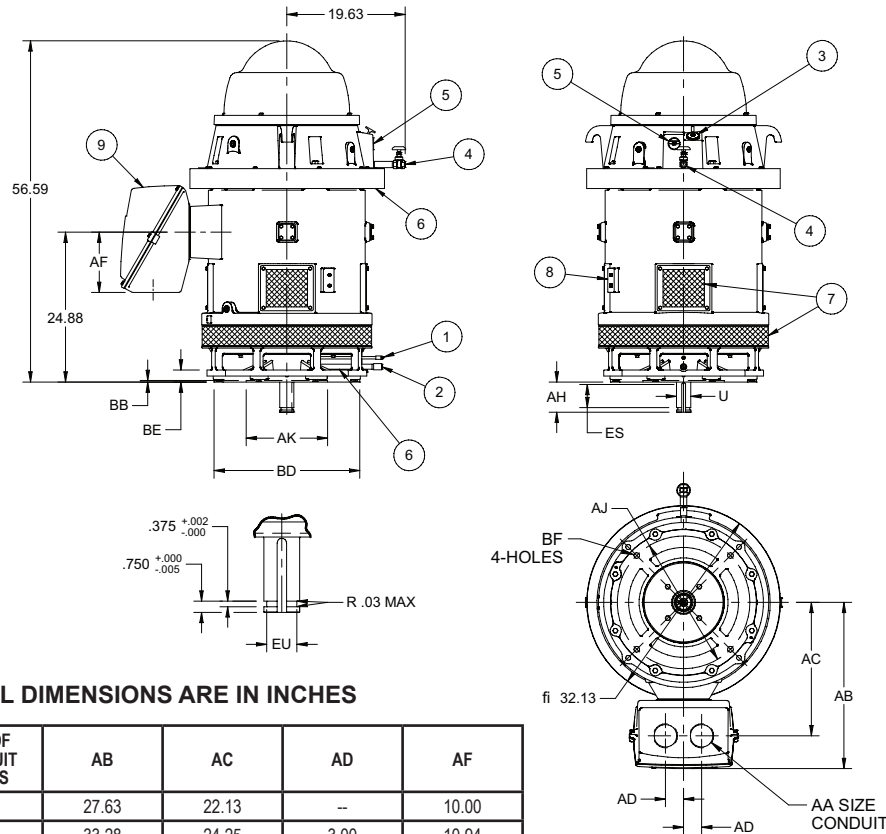

ALL DIMENSIONS ARE IN INCHES

C/BOX VOLUME (CU. IN.)	QTY OF CONDUIT HOLES	AB	AC	AD	AF
2000	1	27.63	22.13	--	10.00
3400	2	33.28	24.25	3.00	10.94

FRAME	AJ	AK +.005	BB MIN	BD MAX	BE	BF
449VPH	14.75	13.500	.25	20.00	2.00	.688
449VP	14.75	13.500		24.50		.688
	22.00			.938		
449VPA	32.00	22.000	30.50	.813		

	POLE (RPM)				U -.001	AH ±.062	ES MIN	EU -.005	SQ KEY
	2 (3600)	4 (1800)	6 (1200)	8 (900)					
HP	ALL	300 & DOWN	200 & DOWN	150 & DOWN	2.125	4.500	3.00	1.750	.500
	--	350 TO 450	250 TO 300	200	2.375	5.000	3.50	2.000	.625
	--	500	350	250	2.625	5.000	3.50	2.250	.625

FEATURE LISTING

1	LOWER GREASE FILL	6	AIR INTAKE, 360° AROUND
2	LOWER GREASE DRAIN	7	AIR EXHAUST, 360° AROUND
3	UPPER SUMP OIL FILL	8	GRD PADS, DIAG OPP, 1/2-13
4	UPPER SUMP OIL DRAIN	9	MAIN CONDUIT BOX
5	UPPER SUMP SIGHT WINDOW	10	49P HAS TWO BOLT CIRCLES

- 1: ALL ROUGH CASTING DIMENSIONS MAY VARY BY .25" DUE TO CASTING VARIATIONS.
- 2: LARGEST MOTOR WIDTH.
- 3: CONDUIT OPENING MAY BE LOCATED IN STEPS OF 90. STANDARD AS SHOWN WITH CONDUIT OPENING DOWN.

TOLERANCES	
FACE RUNOUT	.007 T.I.R.
PERMISSIBLE ECCENTRICITY OF MOUNTING RABBET	.007 T.I.R.
PERMISSIBLE SHAFT RUNOUT	.003 T.I.R.
MAXIMUM SHAFT END PLAY	.010
NON-MACHINED DIMENSIONS MAY VARY BY ±.25	



DIMENSIONS
WEATHER PROTECTED II
HOLLOSHAFT®
FRAME: 449VPH, VP, VPA

TYPES: RV-4

PRINTS
449
RV-4

Typical Dimensions For Reference Only

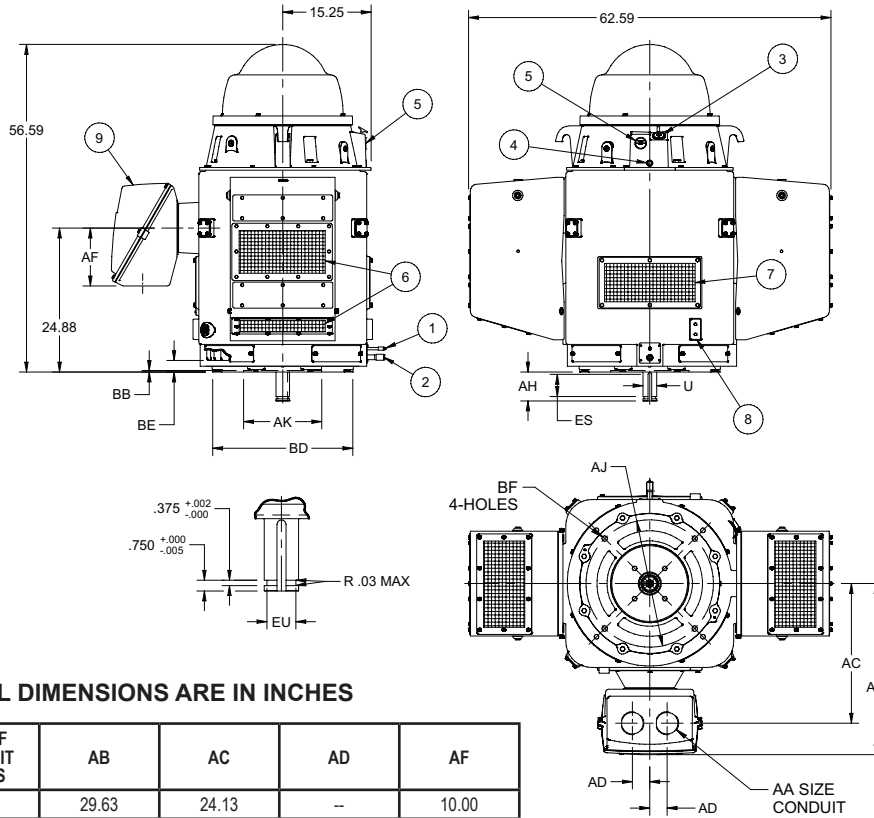

ALL DIMENSIONS ARE IN INCHES

C/BOX VOLUME (CU. IN.)	QTY OF CONDUIT HOLES	AB	AC	AD	AF
2000	1	29.63	24.13	--	10.00
3400	2	35.28	26.25	3.00	10.94

FRAME	AJ	AK +.005	BB MIN	BD MAX	BE	BF
449VPH	14.75	13.500	.25	20.00	2.00	.688
⑩ 449VP	14.75	13.500		24.50		.688
	22.00			.938		
449VPA	32.00	22.000		30.50		.813

	POLE (RPM)				U -.001	AH ±.062	ES MIN	EU -.005	SQ KEY
	2 (3600)	4 (1800)	6 (1200)	8 (900)					
HP	ALL	300 & DOWN	200 & DOWN	150 & DOWN	2.125	4.500	3.00	1.750	.500
	--	350 TO 450	250 TO 300	200	2.375	5.000	3.50	2.000	.625
	--	500	350	250	2.625	5.000	3.50	2.250	.625

FEATURE LISTING

1	LOWER GREASE FILL	6	AIR INTAKE, 360° AROUND
2	LOWER GREASE DRAIN	7	AIR EXHAUST, 360° AROUND
3	UPPER SUMP OIL FILL	8	GRD PADS, DIAG OPP, 1/2-13
4	UPPER SUMP OIL DRAIN	9	MAIN CONDUIT BOX
5	UPPER SUMP SIGHT WINDOW	10	49P HAS TWO BOLT CIRCLES

- 1: ALL ROUGH CASTING DIMENSIONS MAY VARY BY .25" DUE TO CASTING VARIATIONS.
- 2: LARGEST MOTOR WIDTH.
- 3: CONDUIT OPENING MAY BE LOCATED IN STEPS OF 90°. STANDARD AS SHOWN WITH CONDUIT OPENING DOWN.

TOLERANCES	
FACE RUNOUT	.007 T.I.R.
PERMISSIBLE ECCENTRICITY OF MOUNTING RABBET	.007 T.I.R.
PERMISSIBLE SHAFT RUNOUT	.003 T.I.R.
MAXIMUM SHAFT END PLAY	.010
NON-MACHINED DIMENSIONS MAY VARY BY ±.25	



† All marks shown within this document are properties of their respective owners.

DIMENSIONS
WEATHER PROTECTED I
SOLID SHAFT
FRAME: 5000VP, VPH, VPA

TYPES: RV-4 & RVE-4

PRINTS
5000
RV-4, RVE-4

Typical Dimensions For Reference Only

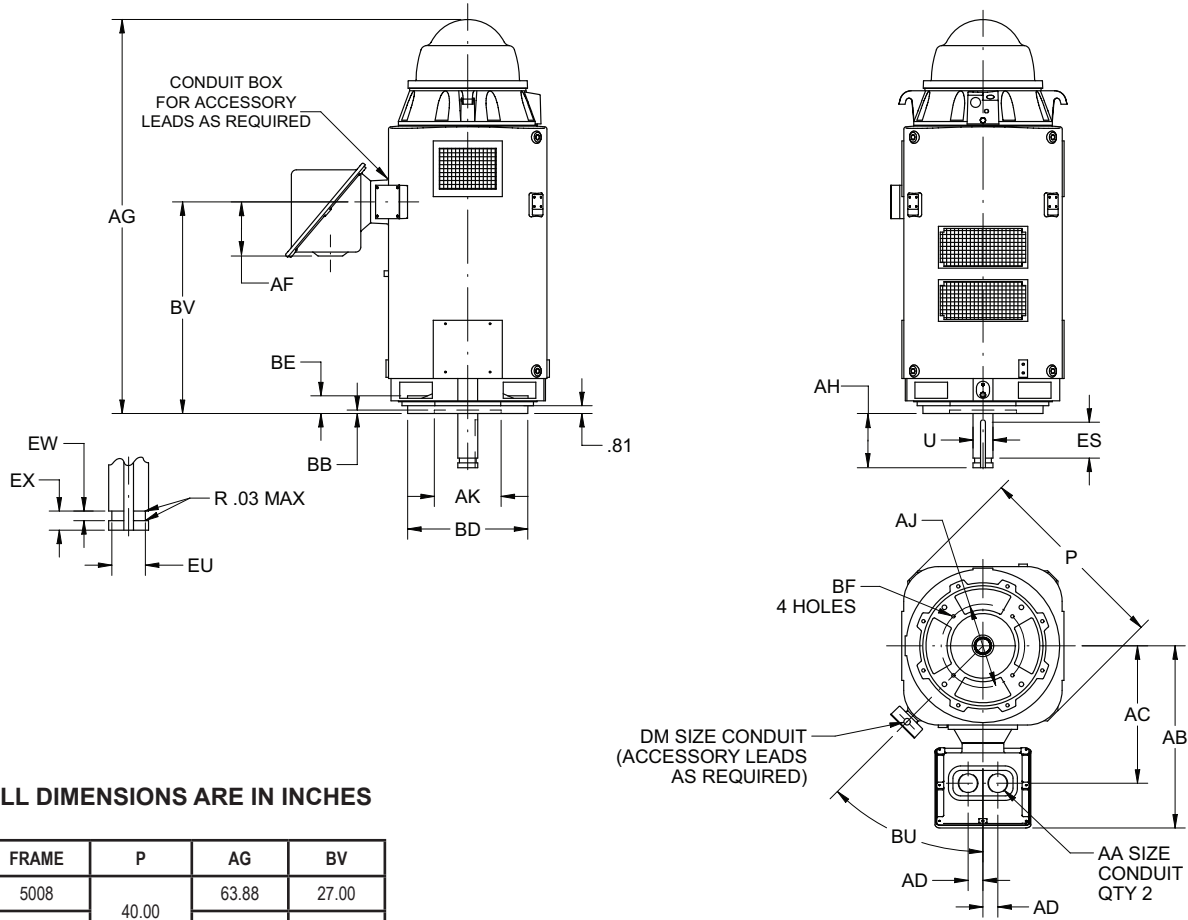

ALL DIMENSIONS ARE IN INCHES

FRAME	P	AG	BV
5008	40.00	63.88	27.00
5012		78.88	42.00

POLE	U -.001	AH ±.062	ES MIN	EU -.005	EW +.002	EX -.005	SQ KEY
2	2.375	5.000	3.50	2.000	.375	.750	.625
4 & SLOWER	3.125	7.000	5.00	2.625	.500	1.000	.750

VOLTS	C/BOX VOLUME (CU. IN.)	AB	AC	AD	AF	BU
0-4800	3400	36.50	27.88	3.00	10.94	45°
4801-6900	5600	36.13	30.13	4.00	10.81	

FRAME	AJ	AK +.005	BB MIN	BD MAX	BE	BF
5000VPH	14.750	13.500	.25	20.00	2.19	.69
5000VP ³	14.750	13.500		24.50		.69
	22.000			30.50		.94
5000VPA	26.000	22.000				.81

AA	DM
2 NPT	0.5 NPT
2.5 NPT	0.75 NPT
3 NPT	1 NPT
3.5 NPT	1.25 NPT
4 NPT	1.5 NPT

TOLERANCES	
FACE RUNOUT	.007 T.I.R.
PERMISSIBLE ECCENTRICITY OF MOUNTING RABBET	.007 T.I.R.
PERMISSIBLE SHAFT RUNOUT	.003 T.I.R.
MAXIMUM SHAFT END PLAY	.010

1: DIMENSIONS MAY VARY BY .25" DUE TO CASTING AND/OR FABRICATION VARIATIONS.
 2: DIMENSIONS AND TOLERANCES ARE SHOWN IN INCHES.
 3: 5000VP HAS TWO BOLT CIRCLES.



† All marks shown within this document are properties of their respective owners.

DIMENSIONS
WEATHER PROTECTED II
SOLID SHAFT
FRAME: 5000VP, VPH, VPA

TYPES: RV-4 & RVE-4

PRINTS
5000
RV-4, RVE-4

Typical Dimensions For Reference Only

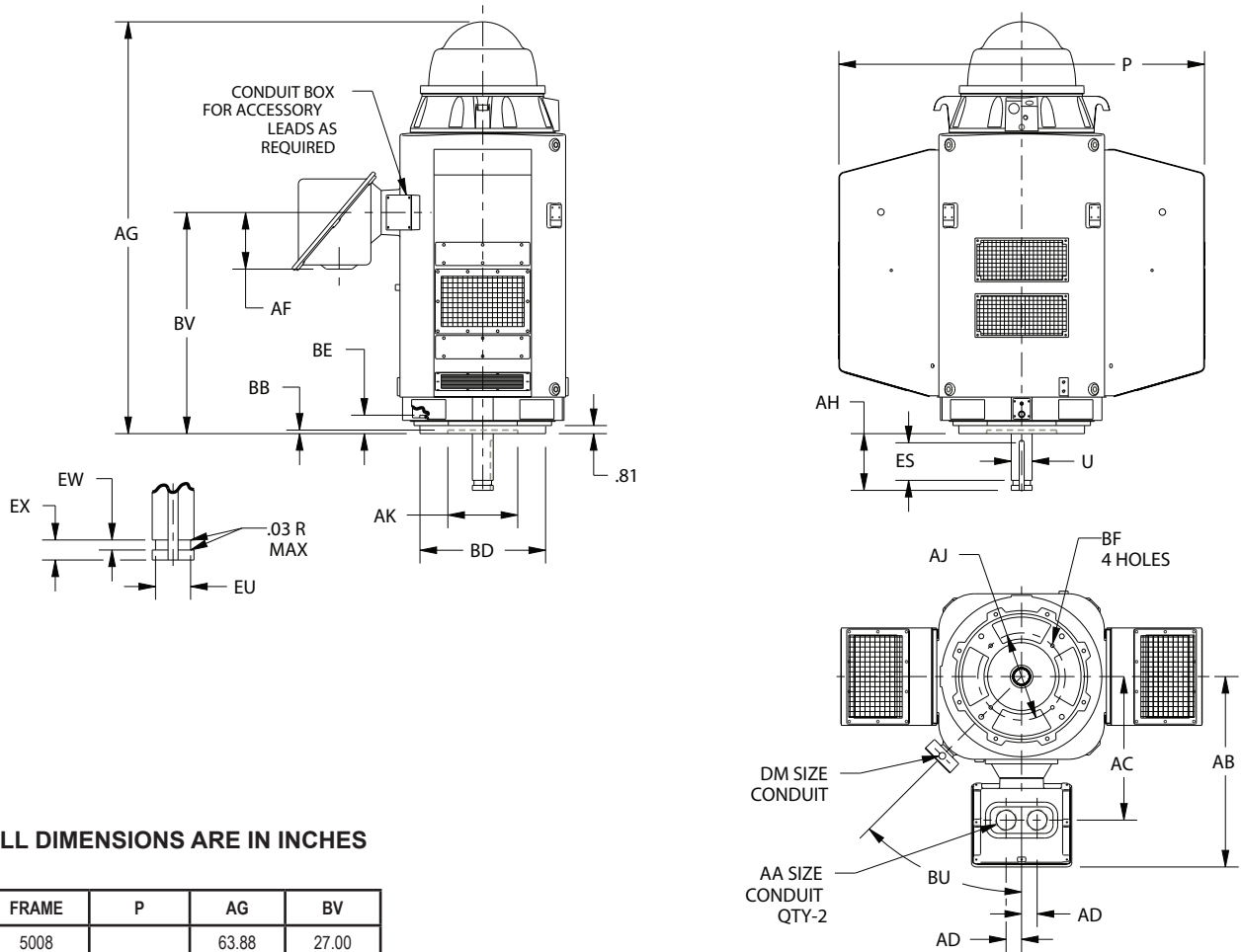

ALL DIMENSIONS ARE IN INCHES

FRAME	P	AG	BV
5008	71.00	63.88	27.00
5012		78.88	42.00

POLE	U -.001	AH ±.062	ES MIN	EU -.005	EW +.002	EX -.005	SQ KEY
2	2.375	5.000	3.50	2.000	.375	.750	.625
4 & SLOWER	3.125	7.000	5.00	2.625	.500	1.000	.750

VOLTS	C/BOX VOLUME (CU. IN.)	AB	AC	AD	AF	BU
0-4800	3400	36.50	27.88	3.00	10.94	45°
4801-6900	5600	36.13	30.13	4.00	10.81	

FRAME	AJ	AK +.005	BB MIN	BD MAX	BE	BF	AA
5000VPH	14.750	13.500	.25	20.00	2.19	.69	2 NPT
5000VP ³	14.750	13.500		24.50		.69	2.5 NPT
	22.000			.94		3.5 NPT	
5000VPA	26.000	22.000	30.50	.81	4 NPT		

DM
0.5 NPT
0.75 NPT
1 NPT
1.25 NPT
1.25 NPT

TOLERANCES	
FACE RUNOUT	.007 T.I.R.
PERMISSIBLE ECCENTRICITY OF MOUNTING RABBET	.007 T.I.R.
PERMISSIBLE SHAFT RUNOUT	.003 T.I.R.
MAXIMUM SHAFT END PLAY	.010

1: DIMENSIONS MAY VARY BY .25" DUE TO CASTING AND/OR FABRICATION VARIATIONS.
 2: DIMENSIONS AND TOLERANCES ARE SHOWN IN INCHES.
 3. 5000VP HAS TWO BOLT CIRCLES.



† All marks shown within this document are properties of their respective owners.

DIMENSIONS
WEATHER PROTECTED I
SOLID SHAFT
FRAME: 5813VP, VPA

TYPE: RV4 & RVE-4

PRINTS
5813
RV-4, RVE-4

Typical Dimensions For Reference Only

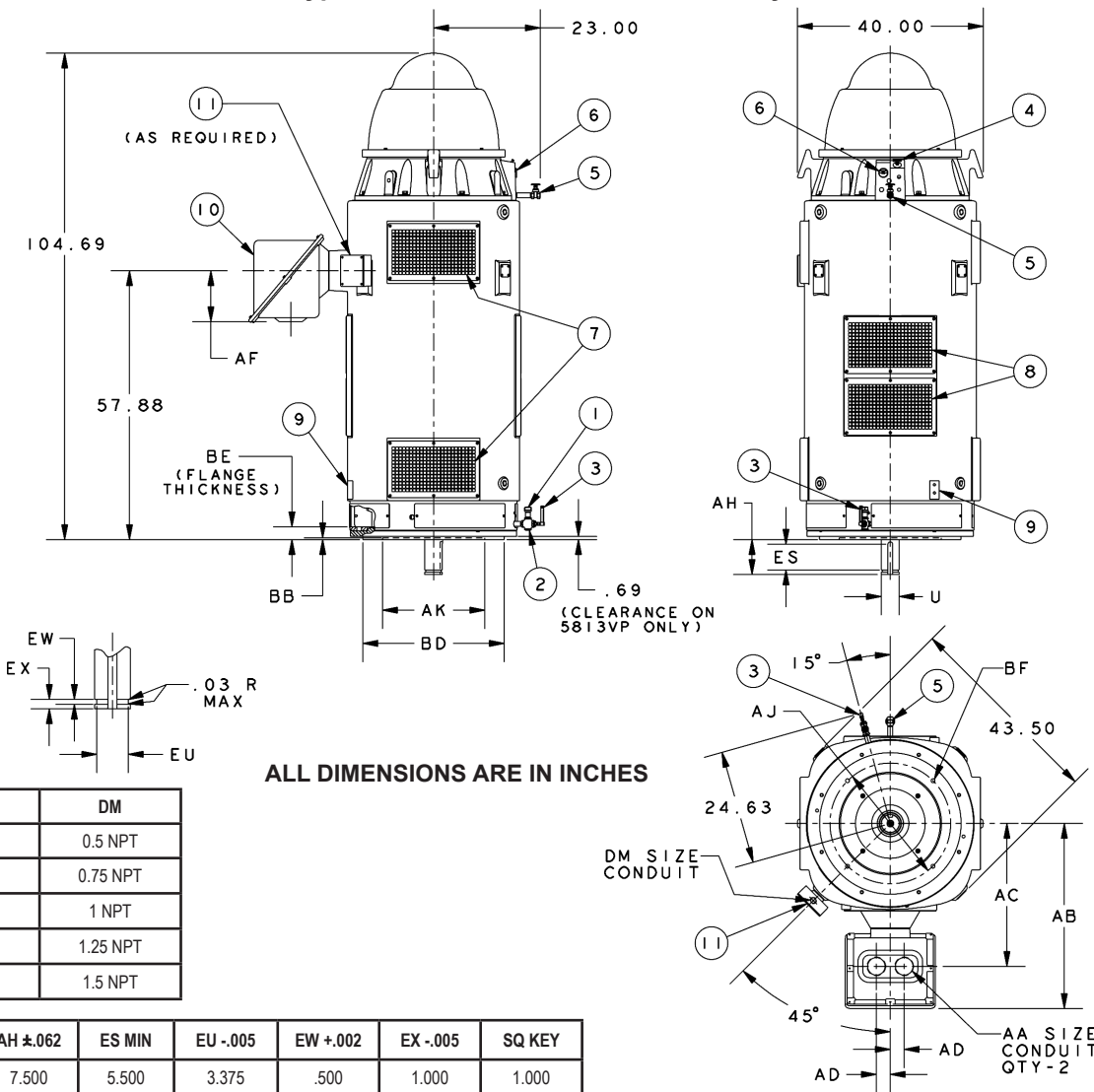

ALL DIMENSIONS ARE IN INCHES

AA	DM
2 NPT	0.5 NPT
2.5 NPT	0.75 NPT
3 NPT	1 NPT
3.5 NPT	1.25 NPT
4 NPT	1.5 NPT

U -.001	AH ±.062	ES MIN	EU -.005	EW +.002	EX -.005	SQ KEY
3.875	7.500	5.500	3.375	.500	1.000	1.000

FRAME	AJ	AK +.005	BB MIN	BD MAX	BE	BF	QTY. OF BF HOLES
5813VP	26.000	22.000	.25	30.50	2.63	.813	4
5813VPA	32.000	26.000		36.00		1.000	8

C/BOX VOLUME (CU. IN.)	AB	AC	AD	AF
.3400	39.37	30.75	3.00	10.94

FEATURE LISTING

1	LOWER SUMP OIL FILL	6	UPPER SUMP SIGHT WINDOW	11	ACCESSORY CONDUIT BOX
2	LOWER SUMP OIL DRAIN	7	AIR INTAKE, 180° APART		
3	LOWER SUMP SIGHT WINDOW	8	AIR EXHAUST, 180° APART		
4	UPPER SUMP OIL FILL	9	GRD PADS, DIAG OPP, .50-13		
5	UPPER SUMP OIL DRAIN	10	MAIN CONDUIT BOX		

NON-MACHINED DIMENSIONS MAY VARY BY +.25.	
TOLERANCES	
FACE RUNOUT	.007 T.I.R.
PERMISSIBLE ECCENTRICITY OF MOUNTING RABBET	.007 T.I.R.
PERMISSIBLE SHAFT RUNOUT	.003 T.I.R.
MAXIMUM SHAFT END PLAY	.010



DIMENSIONS
WEATHER PROTECTED II
SOLID SHAFT
FRAME: 5813VP, VPA

TYPE: RV4 & RVE-4

PRINTS
5813
RV-4, RVE-4

Typical Dimensions For Reference Only

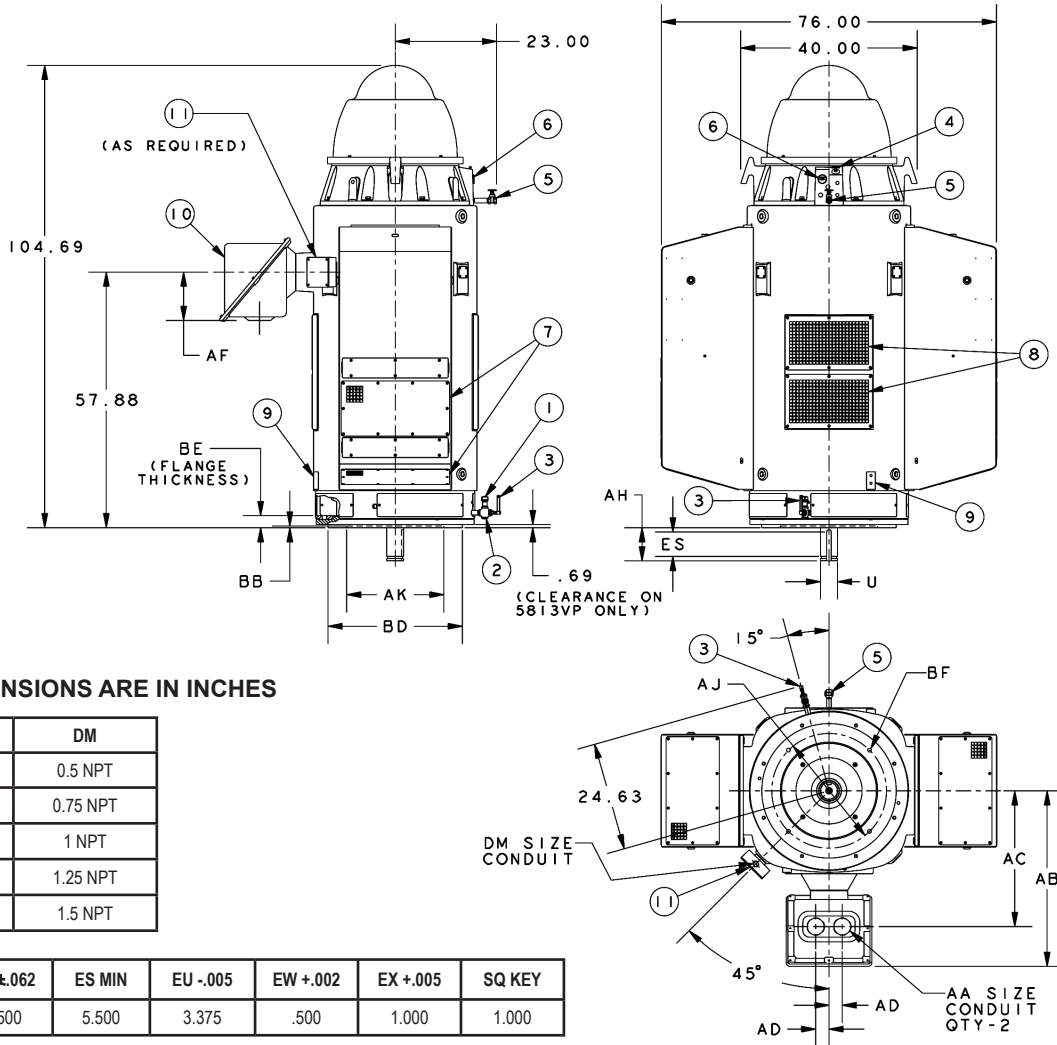

ALL DIMENSIONS ARE IN INCHES

AA	DM
2 NPT	0.5 NPT
2.5 NPT	0.75 NPT
3 NPT	1 NPT
3.5 NPT	1.25 NPT
4 NPT	1.5 NPT

U -.001	AH ±.062	ES MIN	EU -.005	EW +.002	EX +.005	SQ KEY
3.875	7.500	5.500	3.375	.500	1.000	1.000

FRAME	AJ	AK +.005	BB MIN	BD MAX	BE	BF	QTY. OF BF HOLES
5813VP	26.000	22.000	.25	30.50	2.63	.813	4
5813VPA	32.000	26.000		36.00		1.000	8

C/BOX VOLUME (CU. IN.)	AB	AC	AD	AF
.3400	39.37	30.75	3.00	10.94

FEATURE LISTING

1	LOWER SUMP OIL FILL	6	UPPER SUMP SIGHT WINDOW	11	ACCESSORY CONDUIT BOX
2	LOWER SUMP OIL DRAIN	7	AIR INTAKE, 180° APART		
3	LOWER SUMP SIGHT WINDOW	8	AIR EXHAUST, 180° APART		
4	UPPER SUMP OIL FILL	9	GRD PADS, DIAG OPP, .50-13		
5	UPPER SUMP OIL DRAIN	10	MAIN CONDUIT BOX		

TOLERANCES	
FACE RUNOUT	.007 T.I.R.
PERMISSIBLE ECCENTRICITY OF MOUNTING RABBET	.007 T.I.R.
PERMISSIBLE SHAFT RUNOUT	.003 T.I.R.
MAXIMUM SHAFT END PLAY	.010
NON-MACHINED DIMENSIONS MAY VARY BY +.25.	



† All marks shown within this document are properties of their respective owners.

DIMENSIONS
WEATHER PROTECTED I
SOLID SHAFT
FRAME: 6800P, PA

TYPES: HV-4 & HVE4



Typical Dimensions For Reference Only

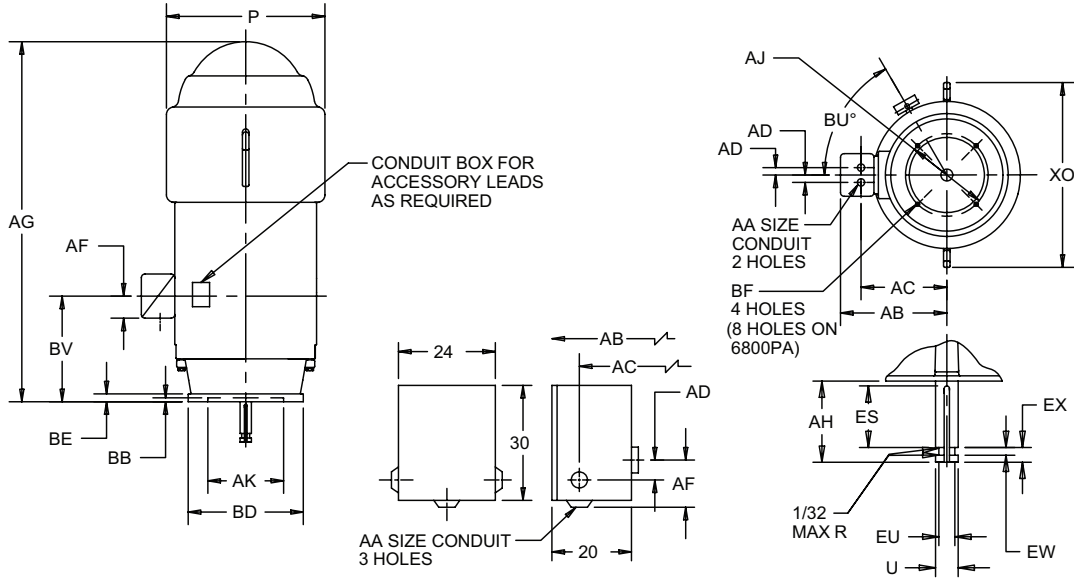

ALL DIMENSIONS ARE IN INCHES

FRAME	XO	P	AG	BV	FRAME	BD	BE	AJ	BF	AK	BB
6808	48.25	42.5	87.562	37.25	6800P	30.5	1.5	26	0.812	22.000	0.25
6810			98.562	48.25	6800PA	36		32	1	26.000	

FRAME	HP	VOLT	AA	AB	AC	AD	AF	D°	DM
6800	ALL	ALL	3.5	35.94	27.833	3	10.937	60	0.75

	POLES (RPM)			U -.001	AH ±.062	ES MIN	EU -.005	EX -.005	EW +.002	SQ KEY
	4 (1800)	6 (1200)	8 (900)							
HP	ALL THRU 800	ALL THRU 500	ALL THRU 400	2.875	7.000	5.000	2.375	1.000	.500	0.75
	900 THRU 1000	600	450 THRU 500	3.125	7.000	5.000	2.625	1.000	.500	0.75
	1250 THRU 1750	700 THRU 1500	500 THRU 1250	3.875	7.500	5.000	3.375	1.000	.500	1

	POLES (RPM)				U -.001	AH ±.062	ES MIN	EU -.005	EX -.005	EW +.002	SQ KEY
	10 (720)	12 (600)	14 (514)	16 (450)							
HP	ALL THRU 300	ALL THRU 250	ALL THRU 200	ALL THRU 200	2.875	7.000	5.000	2.375	1.000	.500	0.75
	350 THRU 400	300	250	250	3.125	7.000	5.000	2.625	1.000	.500	0.75
	450 THRU 800	350 THRU 600	300 THRU 500	300 THRU 500	3.875	7.500	5.000	3.375	1.000	.500	1

TOLERANCES	22.000 AK	13.50 AK
FACE RUNOUT	.007 T.I.R.	.009 F.I.R.
PERMISSIBLE ECCENTRICITY OF MOUNTING RABBET	.007 T.I.R.	.009 F.I.R.
PERMISSIBLE SHAFT RUNOUT	.003 T.I.R.	.003 F.I.R.
MAXIMUM SHAFT END PLAY	.010	.010
TOLERANCE ON AK-DIMENSION	+.005	+.007

- ROUGH DIMENSIONS MAY VARY BY ±.25" DUE TO CASTING AND OR FABRICATION VARIATIONS.
- CONDUIT OPENINGS MAY BE LOCATED IN STEPS OF 90°. STANDARD IS AS SHOWN WITH CONDUIT OPENING DOWN.
- CONDUIT BOX FOR 4000 VOLT MOTORS OVER 1000 HP CANNOT BE ROTATED.

† All marks shown within this document are properties of their respective owners.



DIMENSIONS
WEATHER PROTECTED II
SOLID SHAFT
FRAME: 6800P, PA

TYPES: HV-4 & HVE4

PRINTS
6800
HV-4, HVE-4

Typical Dimensions For Reference Only

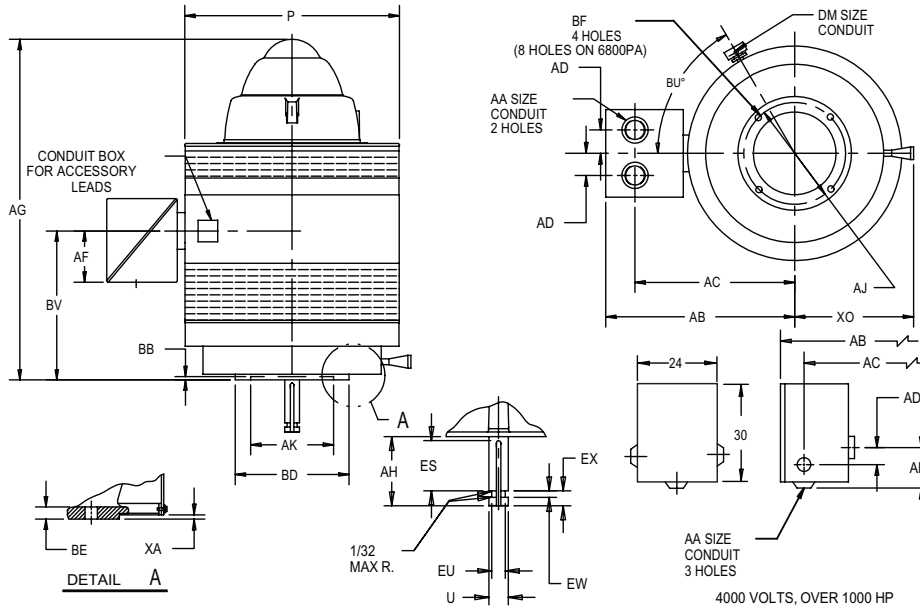

ALL DIMENSIONS ARE IN INCHES

FRAME	HP	VOLT	AA	AB	AC	AD	AF	D°	DM
6800	ALL	460	3.5	46.06	37.437	3	10.937	60	0.75
	ALL	2300							
	THRU 1000	4000							
	1001 & UP	4000		49.312	43.312	11	17.937		

FRAME	XO	P	AG	BV	FRAME	BD	BE	AJ	BF	AK	BB	XA
6808	34.25	56.75	87.562	32.687	6800P	30.5	1.5	26	0.812	22.000	0.25	0.312
6810			98.562	43.687	6800PA	36		32	1	26.000		

HP	POLES (RPM)			U	AH	ES	EU	EX	EW	SQ
	4 (1800)	6 (1200)	8 (900)	-.001	± .062	MIN	-.005	-.005	+.002	KEY
HP	ALL THRU 800	ALL THRU 500	ALL THRU 400	2.875	7.000	5.000	2.375	1.000	.500	0.75
	900 THRU 1000	600	450 THRU 500	3.125	7.000	5.000	2.625	1.000	.500	0.75
	1250 THRU 1750	700 THRU 1500	600 THRU 1250	3.875	7.500	5.000	3.375	1.000	.500	1

HP	POLES (RPM)				U	AH	ES	EU	EX	EW	SQ
	10 (720)	12 (600)	14 (514)	16 (450)	-.001	± .062	MIN	-.005	-.005	+.002	KEY
HP	ALL THRU 300	ALL THRU 250	ALL THRU 200	ALL THRU 200	2.875	7.000	5.000	2.375	1.000	.500	0.75
	350 THRU 400	300	250	250	3.125	7.000	5.000	2.625	1.000	.500	0.75
	450 THRU 800	350 THRU 600	300 THRU 500	300 THRU 500	3.875	7.500	5.000	3.375	1.000	.500	1

TOLERANCES	22.000 AK	26.000 AK
FACE RUNOUT	.007 T.I.R.	.009 F.I.R.
PERMISSIBLE ECCENTRICITY OF MOUNTING RABBET	.007 T.I.R.	.009 F.I.R.
PERMISSIBLE SHAFT RUNOUT	.003 T.I.R.	.003 F.I.R.
MAXIMUM SHAFT END PLAY	.010	.010
TOLERANCE ON AK-DIMENSION	+.005	+.007

- ROUGH DIMENSIONS MAY VARY BY ±1/4" DUE TO CASTING AND OR FABRICATION VARIATIONS.
- CONDUIT OPENINGS MAY BE LOCATED IN STEPS OF 90°. STANDARD IS AS SHOWN WITH CONDUIT OPENING DOWN.
- CONDUIT BOX FOR 4000 VOLT MOTORS OVER 1000 HP CANNOT BE ROTATED.

† All marks shown within this document are properties of their respective owners.



DIMENSIONS
WEATHER PROTECTED I
HOLLOSHAFT®
FRAME: 6813P, PA, PB

TYPES: RV-4 & RVE-4

PRINTS
449
RV-4 & RVE-4

Typical Dimensions For Reference Only

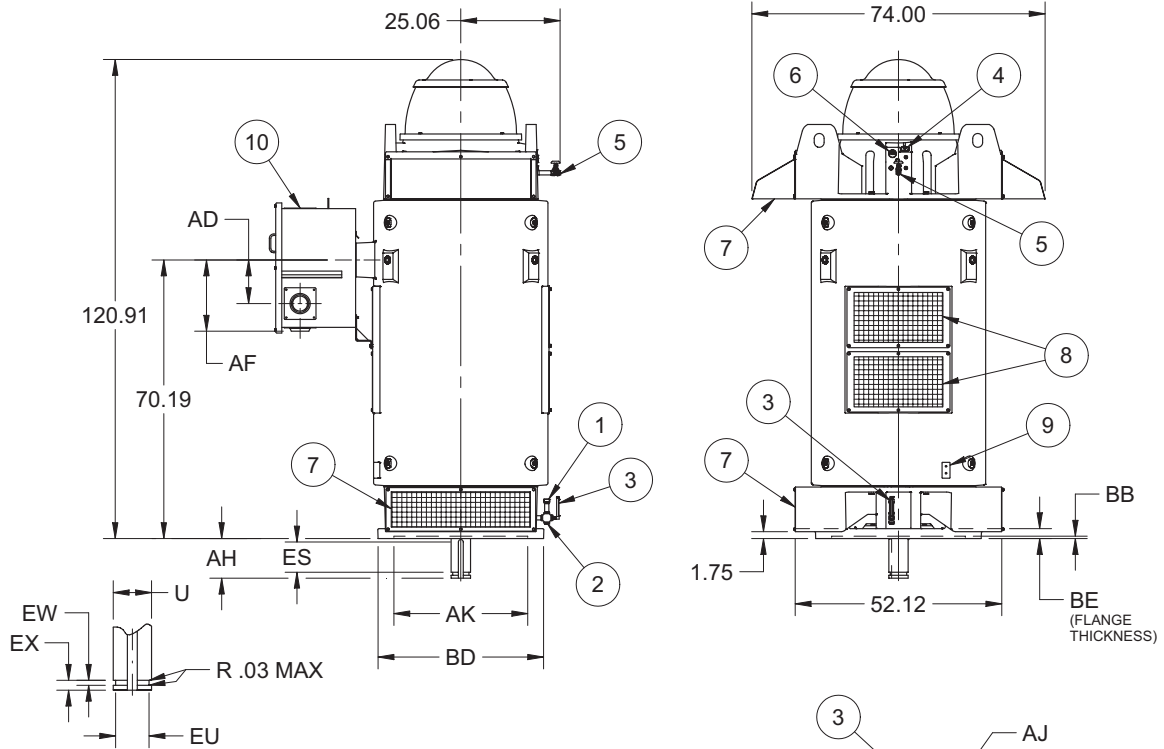

ALL DIMENSIONS ARE IN INCHES

C/BOX VOLUME (CU. IN.)	AB	AC	AD	AF	BB MIN	BE
16,200	46.56	40.31	11.00	17.81	.25	250

U	AH ±.062	ES MIN	EU -.005	EW +.002	EX -.005	SQ KEY
4.875	10.000	7.500	4.125	.750	1.500	1.250

FRAME	AJ	AK +.005	BD MAX	BF
6813P	26.00	22.000	30.50	.813
6813PA	32.00	26.000	36.00	.813
6813PB	39.00	33.750	42.00	1.250

FEATURE LISTING

1	LOWER SUMP OIL FILL	6	UPPER SUMP SIGHT WINDOW
2	LOWER SUMP OIL DRAIN	7	AIR INTAKE, 180° APART
3	LOWER SUMP SIGHT WINDOW	8	AIR EXHAUST, 180° APART
4	UPPER SUMP OIL FILL	9	GRD PADS, DIAG OPP, 1/2-13
5	UPPER SUMP OIL DRAIN	10	MAIN CONDUIT BOX

- 1: ALL ROUGH CASTING DIMENSIONS MAY VARY BY .25" DUE TO CASTING VARIATIONS.
- 2: LARGEST MOTOR WIDTH.
- 3: CONDUIT OPENING MAY BE LOCATED IN STEPS OF 90°. STANDARD AS SHOWN WITH CONDUIT OPENING DOWN.

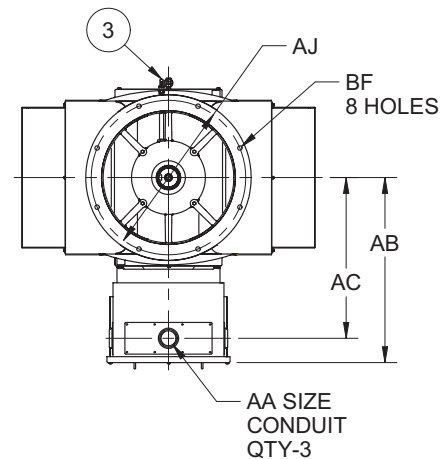

TOLERANCES	
FACE RUNOUT	.009 T.I.R.
PERMISSIBLE ECCENTRICITY OF MOUNTING RABBET	.009 T.I.R.
PERMISSIBLE SHAFT RUNOUT	.003 T.I.R.
MAXIMUM SHAFT END PLAY	.010
NON-MACHINED DIMENSIONS MAY VARY BY ±.25	



DIMENSIONS
WEATHER PROTECTED II
HOLLOSHAFT®
FRAME: 6813P, PA, PB

TYPES: RV-4 & RVE-4

PRINTS
449
RV-4 & RVE-4

Typical Dimensions For Reference Only

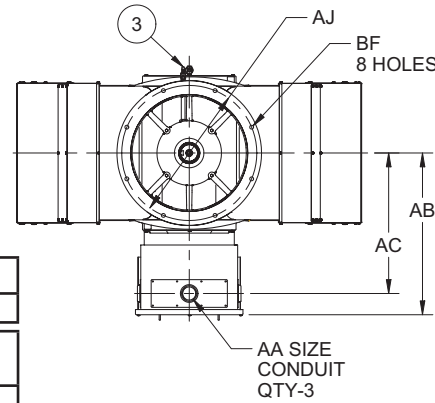
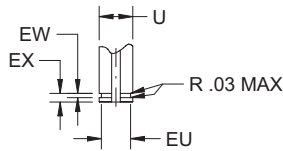
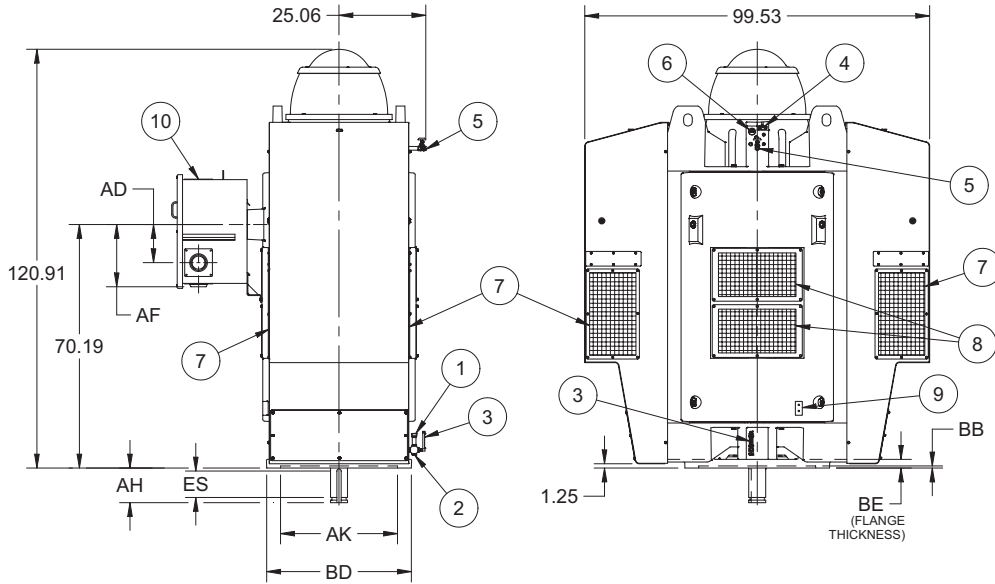

ALL DIMENSIONS ARE IN INCHES

C/BOX VOLUME (CU. IN.)	AB	AC	AD	AF	BB MIN	BE
16,200	46.56	40.31	11.00	17.81	.25	250

U	AH	ES	EU	EW	EX	SQ KEY
.001	±.062	MIN	-.005	+.002	-.005	
4.875	10.000	7.500	4.125	.750	1.500	1.250

FRAME	AJ	AK +.005	BD MAX	BF
6813P	26.00	22.000	30.50	.813
6813PA	32.00	26.000	36.00	.813
6813PB	39.00	33.750	42.00	1.250

FEATURE LISTING

1	LOWER SUMP OIL FILL	6	UPPER SUMP SIGHT WINDOW
2	LOWER SUMP OIL DRAIN	7	AIR INTAKE
3	LOWER SUMP SIGHT WINDOW	8	AIR EXHAUST, 180° APART
4	UPPER SUMP OIL FILL	9	GRD PADS, DIAG OPP, 1/2-13
5	UPPER SUMP OIL DRAIN	10	MAIN CONDUIT BOX

1: ALL ROUGH CASTING DIMENSIONS MAY VARY BY .25" DUE TO CASTING VARIATIONS.
 2: LARGEST MOTOR WIDTH.
 3: CONDUIT OPENING MAY BE LOCATED IN STEPS OF 900.
 STANDARD AS SHOWN WITH CONDUIT OPENING DOWN.

TOLERANCES	
FACE RUNOUT	.009 T.I.R.
PERMISSIBLE ECCENTRICITY OF MOUNTING RABBET	.009 T.I.R.
PERMISSIBLE SHAFT RUNOUT	.003 T.I.R.
MAXIMUM SHAFT END PLAY	.010
NON-MACHINED DIMENSIONS MAY VARY BY ±.25	



† All marks shown within this document are properties of their respective owners.

DIMENSIONS
WEATHER PROTECTED I
SOLID SHAFT
FRAME: 8000PH **TYPES: RV-4 & RVE-4**

PRINTS
8000
RV-4, RVE-4

Typical Dimensions For Reference Only

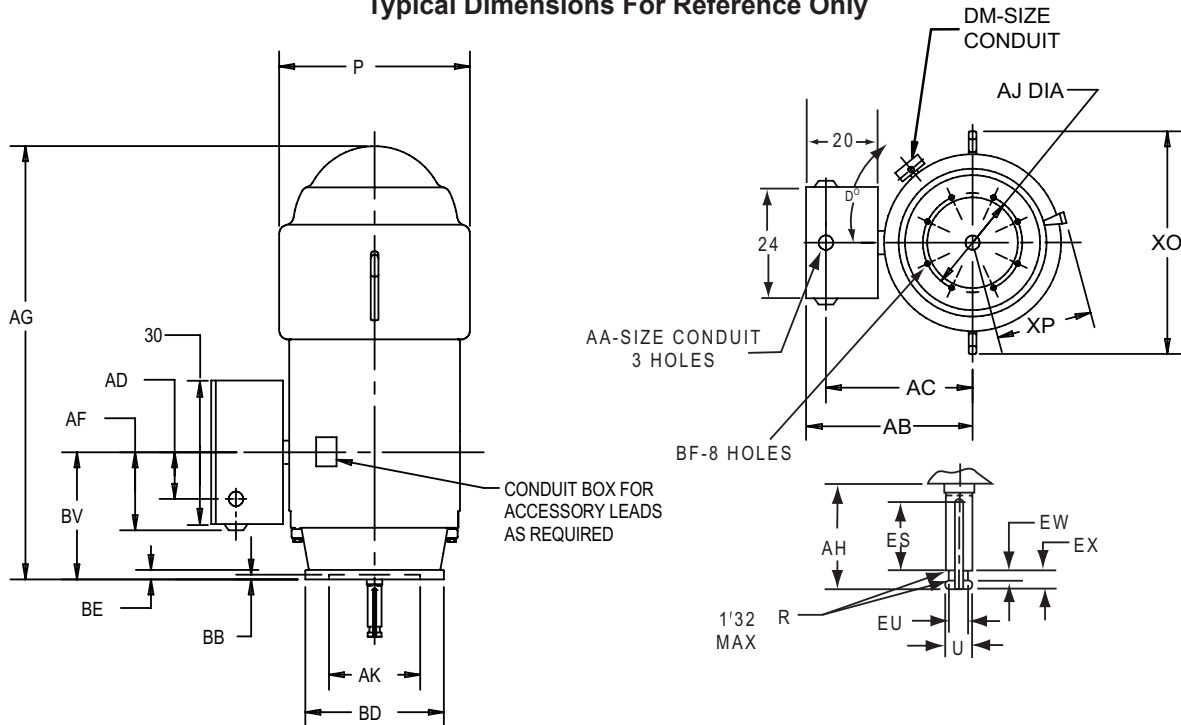

ALL DIMENSIONS ARE IN INCHES

FRAME	XP	XO	P	AG	BV
8006	25	48.25	45	92.062	33.75
8007				96.062	37.75
8008				100.062	41.75
8009				104.062	45.75
8010				108.062	49.75
8011				112.062	53.75

U -.001	AH ±.062	ES MIN	EU -.005	EX -.005	EW +.002	SQ KEY
4.875	10.000	7.500	4.125	1.500	0.75	1.25

FRAME	BD	BE	AJ	BF	AK +.007	BB
8000PH	42	1.75	39	1.125	33.75	0.25

FRAME	HP	VOLT	AA	AB	AC	AD	AF	D°	DM
8000	ALL	ALL	3.5	43.437	37.437	13	17.937	45	1

TOLERANCES	
FACE RUNOUT	.009 T.I.R.
PERMISSIBLE ECCENTRICITY OF MOUNTING RABBET	.007 T.I.R.
PERMISSIBLE SHAFT RUNOUT	.003 T.I.R.
MAXIMUM SHAFT END PLAY	.010

1: ROUGH DIMENSIONS MAY VARY BY ±1/4" DUE TO CASTING AND OR FABRICATION VARIATIONS.

† All marks shown within this document are properties of their respective owners.



DIMENSIONS
WEATHER PROTECTED II
SOLID SHAFT
FRAME: 8000PH

TYPES: RV-4 & RVE-4

PRINTS
8000
RV-4, RVE-4

Typical Dimensions For Reference Only

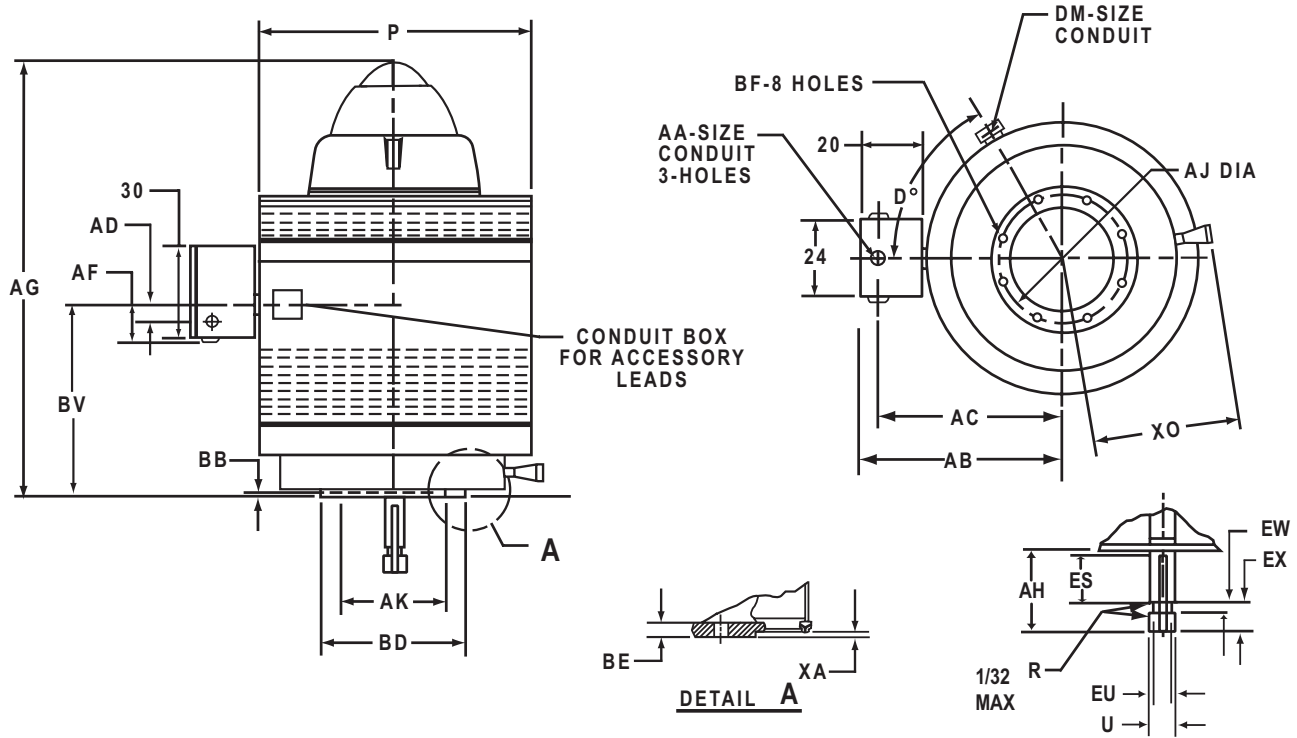

ALL DIMENSIONS ARE IN INCHES

FRAME	XO	P	AG	BV
8006	37.375	67.437	92.062	33.75
8007			96.062	37.75
8008			100.062	41.75
8009			104.062	45.75
8010			108.062	49.75
8011			112.062	53.75

U -.001	AH ±.062	ES MIN	EU -.005	EX -.005	EW +.002	SQ KEY
4.875	10.000	7.500	4.125	1.500	.750	1.25

FRAME	BD	BE	AJ	BF	AK +.007	BB	XO
8000PH	42	1.75	39	1.125	33.750	0.25	1

FRAME	HP	VOLT	AA	AB	AC	AD	AF	D°	DM
8000	ALL	ALL	3.5	54.437	48.437	11	17.937	45	1

TOLERANCES	
FACE RUNOUT	.009 T.I.R.
PERMISSIBLE ECCENTRICITY OF MOUNTING RABBET	.009 T.I.R.
PERMISSIBLE SHAFT RUNOUT	.003 T.I.R.
MAXIMUM SHAFT END PLAY	.010

1: ROUGH DIMENSIONS MAY VARY BY ±1/4" DUE TO CASTING AND OR FABRICATION VARIATIONS.

† All marks shown within this document are properties of their respective owners.



DIMENSIONS
WEATHER PROTECTED I
SOLID SHAFT
FRAME: 9600PH TYPES: RV-4 & RVE-4

PRINTS
9600
RV-4, RVE-4

Typical Dimensions For Reference Only

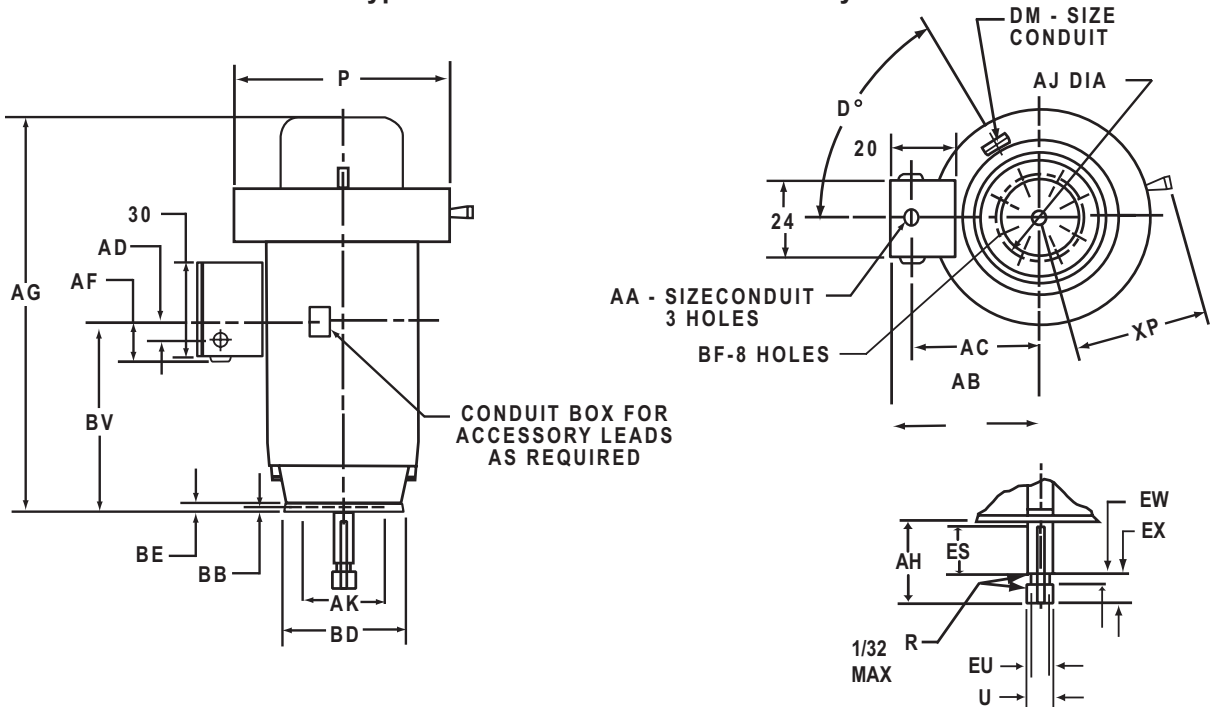

ALL DIMENSIONS ARE IN INCHES

FRAME	XO	P	AG	BV
9601	37.125	62.625	82.75	35.75
9602			86.75	39.75
9603			90.75	43.75
9604			94.75	47.75
9605			98.75	51.75
9606			102.75	55.75
9607			106.75	59.75
9608			110.75	63.75

FRAME	BD	BE	AJ	BF	AK +.007	BB
9600PH	42	1.50	39	1.125	33.750	0.25

FRAME	HP	VOLT	AA	AB	AC	AD	AF	D°	DM
9600	ALL	ALL	3.5	47.375	41.375	11	17.937	90	1

U -.001	AH ±.062	ES MIN	EU -.005	EX -.005	EW +.002	SQ KEY
5.500	11.500	9.000	4.750	1.500	0.75	1.25

TOLERANCES	
FACE RUNOUT	.009 T.I.R.
PERMISSIBLE ECCENTRICITY OF MOUNTING RABBET	.009 T.I.R.
PERMISSIBLE SHAFT RUNOUT	.003 T.I.R.
MAXIMUM SHAFT END PLAY	.010

1: ROUGH DIMENSIONS MAY VARY BY ±1/4" DUE TO CASTING AND OR FABRICATION VARIATIONS.

† All marks shown within this document are properties of their respective owners.



DIMENSIONS
WEATHER PROTECTED II
SOLID SHAFT
FRAME: 9600PH

TYPES: RV-4 & RVE-4

PRINTS
9600
RV-4, RVE-4

Typical Dimensions For Reference Only

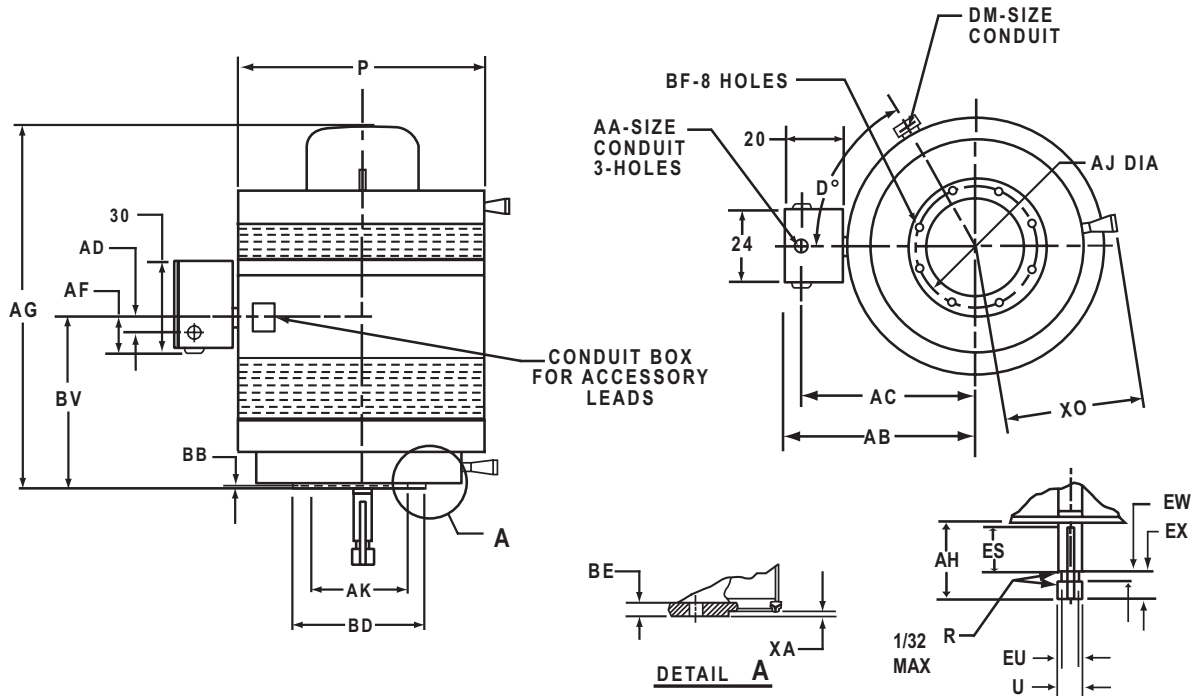

ALL DIMENSIONS ARE IN INCHES

FRAME	X0	P	AG	BV
9601	43.875	72.5	82.75	35.75
9602			86.75	39.75
9603			90.75	43.75
9604			94.75	47.75
9605			98.75	51.75
9606			102.75	55.75
9607			106.75	59.75
9608			110.75	63.75

FRAME	BD	BE	AJ	BF	AK +.007	BB	XA
9600PH	42	1.50	39	1.125	33.750	0.25	1

FRAME	HP	VOLT	AA	AB	AC	AD	AF	D°	DM
9600	ALL	ALL	3.5	56.875	50.875	11	17.937	90	1

U -.001	AH ± .062	ES MIN	EU -.005	EX -.005	EW +.002	SQ KEY
5.500	11.500	9.000	4.750	1.500	0.75	1.25

TOLERANCES	
FACE RUNOUT	.009 T.I.R.
PERMISSIBLE ECCENTRICITY OF MOUNTING RABBET	.009 T.I.R.
PERMISSIBLE SHAFT RUNOUT	.003 T.I.R.
MAXIMUM SHAFT END PLAY	.010

1: ROUGH DIMENSIONS MAY VARY BY ±1/4" DUE TO CASTING AND OR FABRICATION VARIATIONS.

† All marks shown within this document are properties of their respective owners.



DIMENSIONS
TOTALLY ENCLOSED FAN COOLED
SOLID SHAFT
FRAME: 140TC

TYPES: FCTF, CTEF, FTFC & TCEF

PRINTS
140
FCTF, CTEF,
FTFC, TCEF

Typical Dimensions For Reference Only

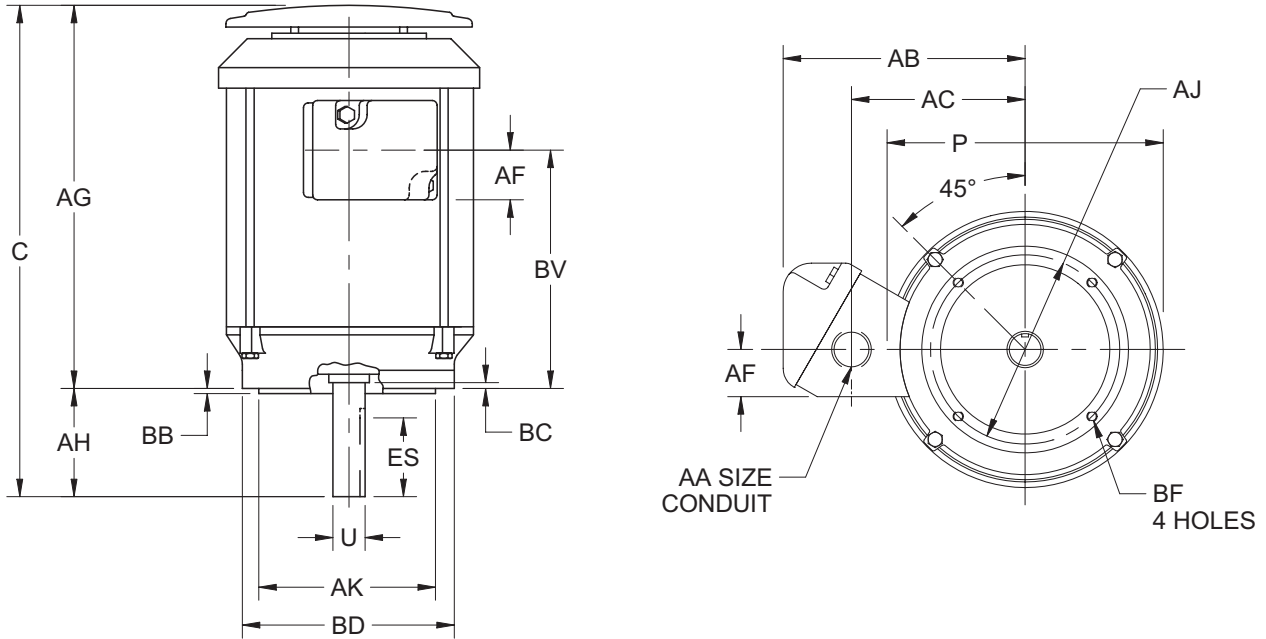

ALL DIMENSIONS ARE IN INCHES

Speed	Frame Size	C	P2	U	AA	AB	AC	AF	AG	AH	AK	BB
2 pole	143	15	7.75	0.875	3/4 NPT	6.38	4.56	1.25	12.88	2.13	4.5	0.13
	145TC											
4 pole	143	16.25	7.75	0.875								
	145TC											

Frame Size	BC	BD	BF	BV	ES	SQ
143	0.13	6.5	3/8-16X.56	6.81	1.41	0.188
145TC						
143	0.13	6.5	3/8-16X.56	8.06	1.41	0.188
145TC						

TOLERANCES	
FACE RUNOUT	.007 T.I.R.
PERMISSIBLE ECCENTRICITY OF MOUNTING RABBET	.007 T.I.R.
PERMISSIBLE SHAFT RUNOUT	.003 T.I.R.

1. ALL ROUGH CASTING DIMENSIONS MAY VARY BY .25" DUE TO CASTING AND/OR FABRICATION VARIATIONS.
 2. LARGEST MOTOR WIDTH.



† All marks shown within this document are properties of their respective owners.

DIMENSIONS
TOTALLY ENCLOSED FAN COOLED
SOLID SHAFT
FRAME: 182TC - 405TC

TYPES: FCTF, CTEF, FTFC & TCEF

PRINTS
180-405
FCTF, CTEF,
FTFC, TCEF

Typical Dimensions For Reference Only

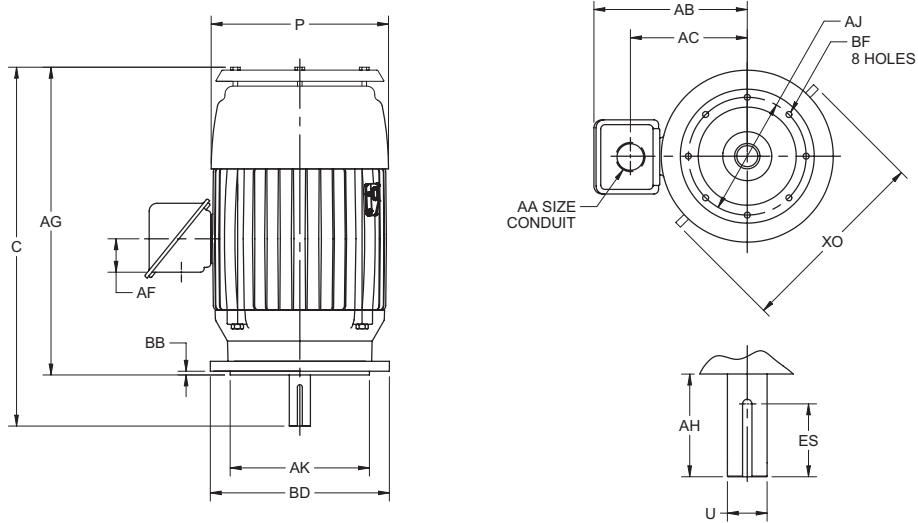

ALL DIMENSIONS ARE IN INCHES

Speed	Frame Size	C	P2	U	AA	AB	AC	AF	AG	AH	AK	BB
182	18.63	9.5	1.125	3/4 NPT	8.03	5.75	2.13	16	2.63	8.5	0.25	0.25
184TC												
210TC	22.75	11.13	1.375	1 NPT	9.75	7.25	2	19.63	3.12	8.5	0.25	0.25
250TC	26.34	13.31	1.625	3/2 NPT	11.5	8.53	2.63	22.59	3.75	8.5	0.31	0.31
280TSC	28.27	15.59	1.625	3/2 NPT	11.94	8.94	2.63	25.27	3	10.5	0.25	0.25
280TC	29.65	14.59	1.875	3/2 NPT	11.94	8.94	2.63	25.27	4.38	10.5	0.25	0.25
320TC	32.63	16.75	2.125	2 NPT	14.25	10.75	3.25	27.63	5	12.5	0.25	0.25
320TSC	31.13	16.75	1.875	2 NPT	14.25	10.75	3.25	27.63	3.5	12.5	0.25	0.25
360TSC	30.95	16.75	1.875	3 NPT	17.13	12.88	4.63	27.45	3.5	12.5	0.25	0.25
360TC	33.08	16.75	2.375	3NPT	17.13	12.88	4.63	27.45	5.63	12.5	0.25	0.25
405TSC	37.63	17.88	2.125	3 NPT	18.69	14.13	4.88	33.63	4	12.5	0.25	0.25
405TC	40.63	20.88	2.875	3 NPT	18.69	14.13	4.88	33.63	7	12.5	0.25	0.25

Frame Size	BC	BD	BF	BV	ES	SQ	BE	XO
182	0.13	9	1/2-13X.75	6.41	1.78	0.25	0.63	12.13
184TC								
210TC	0.25	9	1/2-13X.75	8	2.41	0.313	---	13.76
250TC	0.25	10	1/2-13X.75	10	2.91	0.375	0.63	15.96
280TSC	0.25	11.25	1/2-13X.75	10.5	1.91	375	---	18.52
280TC	0.25	11.25	1/2-13X.75	10.5	3.28	0.5	---	18.52
320TC	---	14	5/8 11X.94	11.5	3.91	0.5	---	21.14
320TSC	---	14	5/8 11X.94	11.5	2.03	0.5	---	21.14
360TSC	---	14	5/8 11X.94	12.25	2.03	0.5	---	23
360TC	---	14	5/8 11X.94	12.25	4.28	0.625	---	23
405TSC	---	15.5	5/8 11X.94	15.63	3.13	0.5	---	26
405TC	---	15.5	5/8 11X.94	15.63	5.65	0.75	---	26

- 1: ALL ROUGH CASTING DIMENSIONS MAY VARY BY .25" DUE TO CASTING AND/OR FABRICATION VARIATIONS.
- 2: TAP SIZE AND BOLT PENETRATION ALLOWANCE.
- 3: ALL TAPPED HOLES ARE UNIFIED NATIONAL COARSE RIGHT | HAND THREAD
- 4: CONDUIT OPENING MAY BE LOCATED IN STEPS OF 90°. STANDARD AS SHOWN WITH CONDUIT OPENING DOWN.
- 5: LARGEST MOTOR WIDTH.
- 6: TOLERANCES SHOWN ARE IN INCHES ONLY.

TOLERANCES	
FACE RUNOUT	.007 T.I.R.
PERMISSIBLE ECCENTRICITY OF MOUNTING RABBET	.007 T.I.R.
PERMISSIBLE SHAFT RUNOUT	.003 T.I.R.
FOR SPECIAL SHAFT RUNOUT (BALL BRG)	.0015 T.I.R.



† All marks shown within this document are properties of their respective owners.

DIMENSIONS
TOTALLY ENCLOSED FAN COOLED
SOLID SHAFT
FRAME: 440TC

TYPES: FCTF, CTEF, FTFC & TCEF

PRINTS
440
FCTF, CTEF,
FTFC, TCEF

Typical Dimensions For Reference Only

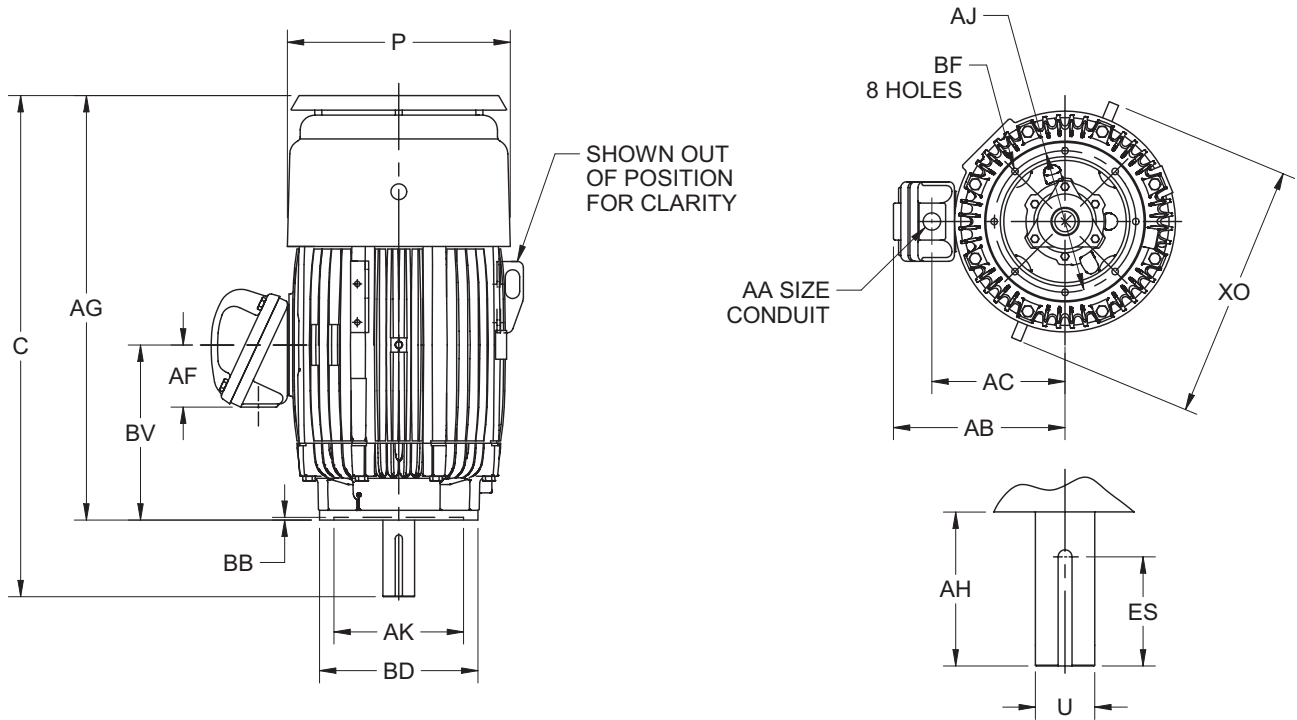

ALL DIMENSIONS ARE IN INCHES

Frame Size	C	P2	U	AA	AB	AC	AF	AG	AH	AK	BB
444	42.97	23.5	2.375	3.5 NPT	18.88	14.76	5.28	38.47	4.5	16	0.25
445TSC											
444	46.72	23.5	3.375	3.5 NPT	18.88	14.76	5.28	38.47	8.25	16	0.25
445TC											
447TSC	46.47	23.5	2.375	3.5 NPT	18.88	14.76	5.28	41.97	4.5	16	0.25

Frame Size	BD	BF	BV	ES	SQ	X0
444	18	5/8-11X.94	16	3.03	0.625	27.75
445TSC						
444	18	5/8-11X.94	16	6.91	0.875	27.75
445TC						
447TSC	18	5/8-11X.94	17.75	3.03	0.625	27.75

TOLERANCES	
FACE RUNOUT	.007 T.I.R.
PERMISSIBLE ECCENTRICITY OF MOUNTING RABBET	.007 T.I.R.
PERMISSIBLE SHAFT RUNOUT	.003 T.I.R.

1. ALL ROUGH CASTING DIMENSIONS MAY VARY BY .25" DUE TO CASTING AND/OR FABRICATION VARIATIONS.
 2. LARGEST MOTOR WIDTH.

† All marks shown within this document are properties of their respective owners.



DIMENSIONS
TOTALLY ENCLOSED FAN COOLED
SOLID SHAFT
FRAME: 143VP - 286VP

TYPES: CTV & TVC

PRINTS
143-286
CTV, TVC

Typical Dimensions For Reference Only

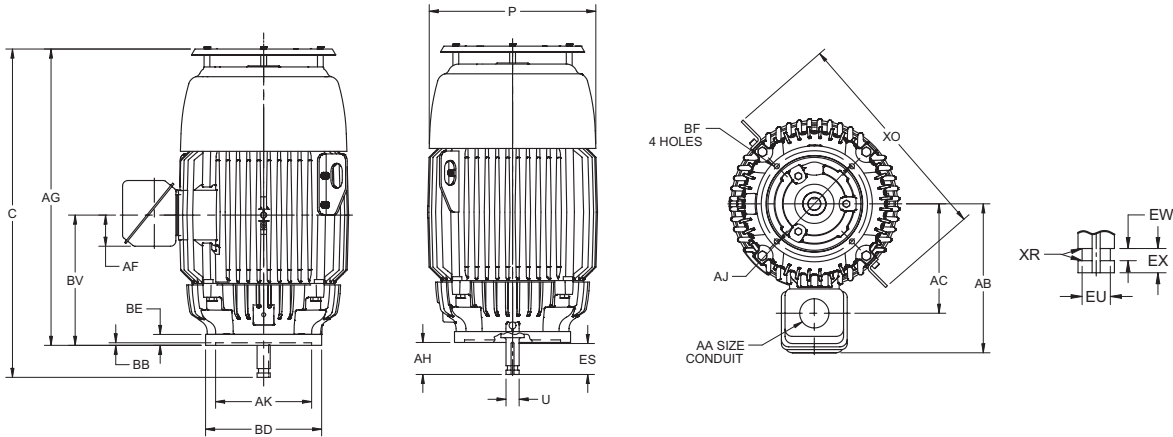

ALL DIMENSIONS ARE IN INCHES

FRAME	AF	AG	BE	BV	XO
143, 145VP	1.75	12.63	0.56	6.81	-
182, 184VP	2	17.25	0.63	7.63	12.16
213, 215VP	2	19.66	0.63	8	13.75
254, 256VP, VPH	2.53	23.78	0.63	10	15.96
284, 286VP, VPA, VPH	3.25	26	0.94	11.19	18.81
284, 286VPZ, VPAZ, VPHZ	2.562	28.125	0.94	14.75	15.875

FRAME	C	P3	AA	AB	AC
143, 145VP	15.38	7.75	0.75	7.88	6.31
182, 184VP	20	9.5	0.75	7.88	5.69
213, 215VP	22.41	11	1	8.88	6.71
254, 256VP, VPH	26.53	13.31	1.50	11.31	8.5
284, 286VP, VPA, VPH	28.75	14.59	2.0	13.31	9.69
284, 286VPZ, VPAZ, VPHZ	32.625	13.375	1.5	10.75	8.25

FRAME	U2	V MIN	AH ± .062	AJ	AK	BB MIN	BD	BF	ES MIN	EU -.005	SQ KEY
143, 145VP	0.875	2.75	2.75	9.125	8.25	0.19	10	0.44	1.28	0.688	0.188
182, 184VP	1.125	2.75	2.75	9.125	8.25	0.19	10	0.44	1.28	0.875	0.25
213, 215VP	1.125	2.75	2.75	9.125	8.25	0.19	10	0.44	1.28	0.875	0.25
254, 256VP	1.125	2.75	2.75	9.125	8.25	0.19	10	0.44	1.28	0.875	0.25
254, 256VPH	1.125	2.75	2.75	9.125	8.25	0.19	12	0.44	1.28	0.875	0.25
284, 286VP	1.125	2.75	2.75	9.125	8.25	0.19	10	0.44	1.28	0.875	0.25
284, 286VPA	1.125	2.75	2.75	9.125	8.25	0.19	12	0.44	1.28	0.875	0.25
284, 286VPH	1.125	2.75	2.75	14.75	13.5	0.25	16.5	0.69	1.28	0.875	0.25
284, 286VPZ	1.625	4.5	4.5	9.125	8.25	0.19	10	0.44	3.06	1.25	0.375
284, 286VPAZ	1.625	4.5	4.5	9.125	8.25	0.19	12	0.44	3.06	1.25	0.375
284, 286VPHZ	1.625	4.5	4.5	14.75	13.5	0.25	16.5	0.69	3.06	1.25	0.375

- 1: ALL ROUGH CASTING DIMENSIONS MAY VARY BY .25" DUE TO CASTING VARIATIONS.
- 2: SHAFT EXTENSION DIAMETER TOLERANCE: +.0000; -.0005 UP 1-1/2" INCLUSIVE. LARGE DIAMETERS: +.000; -.001.
3. LARGEST MOTOR WIDTH.
4. CONDUIT OPENING MAY BE LOCATED IN STEPS OF 90°. STANDARD AS SHOWN WITH CONDUIT OPENING DOWN.

TOLERANCES	8.25 AK	13.5 AK
FACE RUNOUT	.004 T.I.R.	.007 T.I.R.
PERMISSIBLE ECCENTRICITY OF MOUNTING RABBET	.004 T.I.R.	.007 T.I.R.
PERMISSIBLE SHAFT RUNOUT	.002 T.I.R.	.002 T.I.R.
"AK" DIMENSION	+.000; -.003	+.000; -.005



† All marks shown within this document are properties of their respective owners.

DIMENSIONS
TOTALLY ENCLOSED FAN COOLED
SOLID SHAFT
FRAME: 143HP - 286HPZ
TVS

PRINTS
143-286
TV, TVE,
TVI, TVS

TYPES: TV, TVE, TVI &

Typical Dimensions For Reference Only

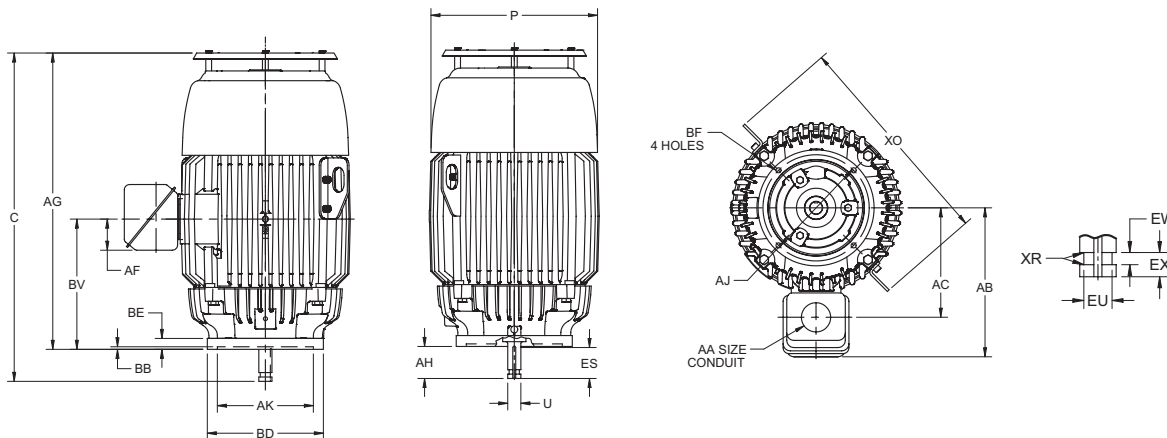

ALL DIMENSIONS ARE IN INCHES

FRAME	AF	AG	BE	BV	XO
143, 145HP	1.75	12.63	0.56	6.81	-
182, 184HP	2	17.25	0.63	7.63	12.16
213, 215HP	2	19.66	0.63	8	13.75
254, 256HP, HPH	2.53	23.78	0.63	10	15.96
284, 286HP, HPA, HPH	3.25	26	0.94	11.19	18.81
284, 286HPZ, HPAZ, HPHZ	2.562	28.125	0.94	14.75	15.875

FRAME	C	P3	AA	AB	AC
143, 145HP	15.38	7.75	0.75	7.88	6.31
182, 184HP	20	9.5	0.75	7.88	5.69
213, 215HP	22.41	11	1	8.88	6.71
254, 256HP, HPH	26.53	13.31	1.50	11.31	8.5
284, 286HP, HPA, HPH	28.75	14.59	2.0	13.31	9.69
284, 286HPZ, HPAZ, HPHZ	32.625	13.375	1.5	10.75	8.25

FRAME	U2	V MIN	AH ± .062	AJ	AK	BB MIN	BD	BF	ES MIN	"EU -.005"	SQ KEY
143, 145HP	0.875	2.75	2.75	9.125	8.25	0.19	10	0.44	1.28	0.688	0.188
182, 184HP	1.125	2.75	2.75	9.125	8.25	0.19	10	0.44	1.28	0.875	0.25
213, 215HP	1.125	2.75	2.75	9.125	8.25	0.19	10	0.44	1.28	0.875	0.25
254, 256HP	1.125	2.75	2.75	9.125	8.25	0.19	10	0.44	1.28	0.875	0.25
254, 256HP	1.125	2.75	2.75	9.125	8.25	0.19	12	0.44	1.28	0.875	0.25
284, 286HP	1.125	2.75	2.75	9.125	8.25	0.19	10	0.44	1.28	0.875	0.25
284, 286HPA	1.125	2.75	2.75	9.125	8.25	0.19	12	0.44	1.28	0.875	0.25
284, 286HPH	1.125	2.75	2.75	14.75	13.5	0.25	16.5	0.69	1.28	0.875	0.25
284, 286HPZ	1.625	4.5	4.5	9.125	8.25	0.19	10	0.44	3.06	1.25	0.375
284, 286HPAZ	1.625	4.5	4.5	9.125	8.25	0.19	12	0.44	3.06	1.25	0.375
284, 286HPHZ	1.625	4.5	4.5	14.75	13.5	0.25	16.5	0.69	3.06	1.25	0.375

- 1: ALL ROUGH CASTING DIMENSIONS MAY VARY BY .25" DUE TO CASTING VARIATIONS.
- 2: SHAFT EXTENSION DIAMETER TOLERANCE: +.0000; -.0005 UP 1-1/2" INCLUSIVE. LARGE DIAMETERS: +.000; -.001.
3. LARGEST MOTOR WIDTH.
4. CONDUIT OPENING MAY BE LOCATED IN STEPS OF 90°. STANDARD AS SHOWN WITH CONDUIT OPENING DOWN.

TOLERANCES	8.25 AK	13.5 AK
FACE RUNOUT	.004 T.I.R.	.006 T.I.R.
PERMISSIBLE ECCENTRICITY OF MOUNTING RABBET	.004 T.I.R.	.006 T.I.R.
PERMISSIBLE SHAFT RUNOUT	.002 T.I.R.	.002 T.I.R.
*AK" DIMENSION	+.000; -.003	+.000; -.005



† All marks shown within this document are properties of their respective owners.

DIMENSIONS
TOTALLY ENCLOSED FAN COOLED
SOLID SHAFT
FRAME: 324VP - 447VP

TYPES: TV, TVE, TVI & TVS

PRINTS
324-447
TV, TVE,
TVI, TVS

Typical Dimensions For Reference Only

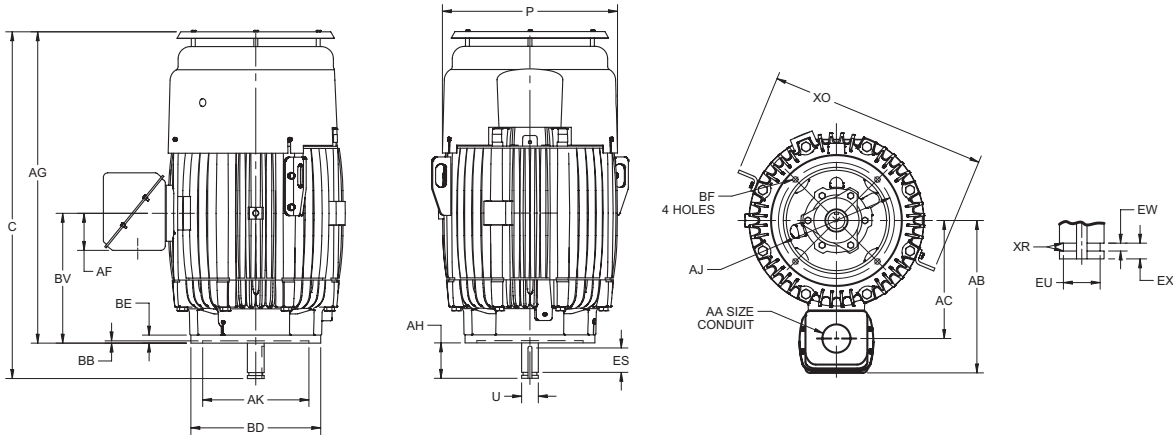

ALL DIMENSIONS ARE IN INCHES

FRAME	AF	AG	BE	BV	XO
324, 326VP, VPH	3.25	28.16	1	11.94	21.13
364, 365	3.38	29.22	1	12.94	23
404, 405	4.72	34.38	1	15.63	26
444, 445	4.72	39.56	1	16.5	27.75
447	4.72	43.06	1	18.25	27.75

FRAME	C	P3	AA	AB	AC
324, 326VP, VPH	32.66	16.56	2	14	10.75
364, 365	33.72	18	3	16.5	12.19
404, 405	38.88	20.88	3	18.42	14.13
444, 445	44.06	22.25	3	19.38	15
447	47.56	22.25	3	19.38	15

FRAME	U2	V MIN	AH ±.062	AJ	AK	BB MIN	BD	BF	ES MIN	EU -.005	SQ KEY
324, 326VP	1.625	4.50	4.50	14.75	13.50	0.25	16.5	0.69	3.03	1.25	0.375
324, 326VPH	1.625	4.50	4.50	9.125	8.25	0.19	12	0.44	3.03	1.25	0.375
364, 365VP	1.625	4.50	4.50	14.75	13.50	0.25	16.5	0.69	3.03	1.25	0.375
364, 365VPZ	2.125	4.50	4.50	14.75	13.50	0.25	16.5	0.69	3.03	1.75	0.50
404, 405VP	1.625	4.50	4.50	14.75	13.50	0.25	16.5	0.69	3.03	1.25	0.375
404, 405VPA	1.625	4.50	4.50	14.75	13.50	0.25	20	0.69	3.03	1.75	0.375
444, 445, 447VP	2.125	4.50	4.50	14.75	13.50	0.25	16.5	0.69	3.03	1.75	0.50
444, 445, 447VPA	2.125	4.50	4.50	14.75	13.50	0.25	20.0	0.69	3.03	1.75	0.50

TOLERANCES	8.25 AK	13.50 A.K.
"AK" DIMENSION	.003; -0.000	.005; -.000
FACE RUNOUT	.004 T.I.R.	.007 T.I.R.
PERMISSIBLE ECCENTRICITY OF MOUNTING RABBET	.004 T.I.R.	.007 T.I.R.
PERMISSIBLE SHAFT RUNOUT	.002 T.I.R.	.002 T.I.R.

- 1: ALL ROUGH CASTING DIMENSIONS MAY VARY BY .25" DUE TO CASTING VARIATIONS.
- 2: LARGEST MOTOR WIDTH
- 3: CONDUIT OPENING MAY BE LOCATED IN STEPS OF 90°. STANDARD AS SHOWN WITH CONDUIT OPENING DOWN.

† All marks shown within this document are properties of their respective owners.



DIMENSIONS
TOTALLY ENCLOSED FAN COOLED
SOLID SHAFT
FRAME: 324HP - 447HP

TYPES: TV, TVE, TVI & TVS

PRINTS
324-447
TV, TVE,
TVI, TVS

Typical Dimensions For Reference Only

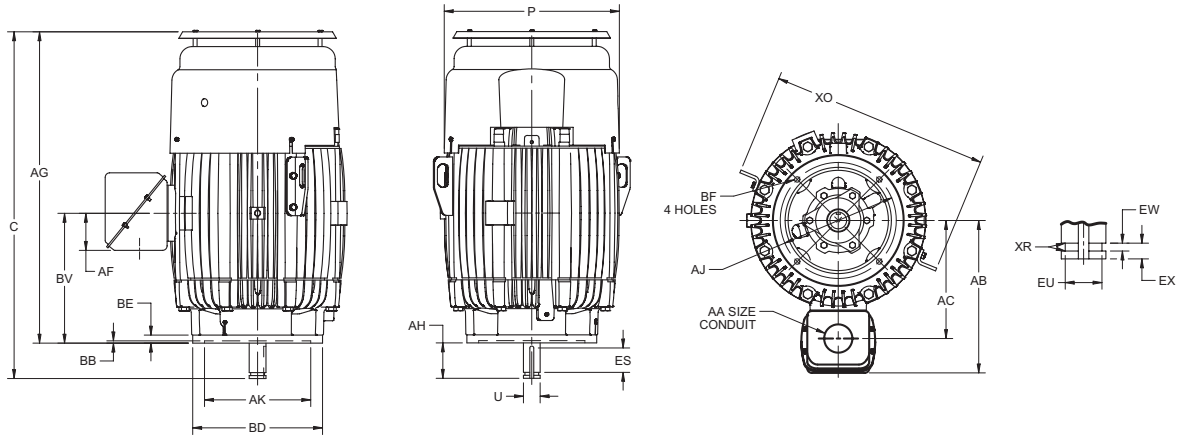

ALL DIMENSIONS ARE IN INCHES

FRAME	AF	AG	BE	BV	XO
324, 326HP, HPH	3.25	28.16	1	11.94	21.13
364, 365	3.38	29.22	1	12.94	23
404, 405	4.72	34.38	1	15.63	26
444, 445	4.72	39.56	1	16.5	27.75
447	4.72	43.06	1	18.25	27.75

FRAME	C	P3	AA	AB	AC
324, 326HP, HPH	32.66	16.56	2	14	10.75
364, 365	33.72	18	3	16.5	12.19
404, 405	38.88	20.88	3	18.42	14.13
444, 445	44.06	22.25	3	19.38	15
447	47.56	22.25	3	19.38	15

FRAME	U2	V MIN	AH ± .062	AJ	AK	BB MIN	BD	BF	ES MIN	EU -.005	SQ KEY
324, 326HP	1.625	4.50	4.50	14.750	13.50	0.25	16.5	0.69	3.03	1.25	0.375
324, 326HPH	1.625	4.50	4.50	9.125	8.25	0.19	12	0.44	3.03	1.25	0.375
364, 365HP	1.625	4.50	4.50	14.75	13.50	0.25	16.5	0.69	3.03	1.25	0.375
364, 365HPZ	2.125	4.50	4.50	14.75	13.50	0.25	16.5	0.69	3.03	1.75	0.50
404, 405HP	1.625	4.50	4.50	14.75	13.50	0.25	16.5	0.69	3.03	1.25	0.375
404, 405HPA	1.625	4.50	4.50	14.75	13.50	0.25	20	0.69	3.03	1.75	0.375
444, 445, 447HP	2.125	4.50	4.50	14.75	13.50	0.25	16.5	0.69	3.03	1.75	0.50
444, 445, 447HPA	2.125	4.50	4.50	14.75	13.50	0.25	20.0	0.69	3.03	1.75	0.50

TOLERANCES	8.25 AK	13.50 A.K.
"AK" DIMENSION	.003; -0.000	.005; -.000
FACE RUNOUT	.004 T.I.R.	.006 T.I.R.
PERMISSIBLE ECCENTRICITY OF MOUNTING RABBET	.004 T.I.R.	.006 T.I.R.
PERMISSIBLE SHAFT RUNOUT	.002 T.I.R.	.002 T.I.R.

- 1: ALL ROUGH CASTING DIMENSIONS MAY VARY BY .25" DUE TO CASTING VARIATIONS.
- 2: LARGEST MOTOR WIDTH
- 3: CONDUIT OPENING MAY BE LOCATED IN STEPS OF 90°. STANDARD AS SHOWN WITH CONDUIT OPENING DOWN.

† All marks shown within this document are properties of their respective owners.



DIMENSIONS
HAZARDOUS LOCATION
SOLID SHAFT
FRAME: 143HP - 286HPZ

TYPE: LV & LVE

PRINTS
143-286
LV, LVE

Typical Dimensions For Reference Only

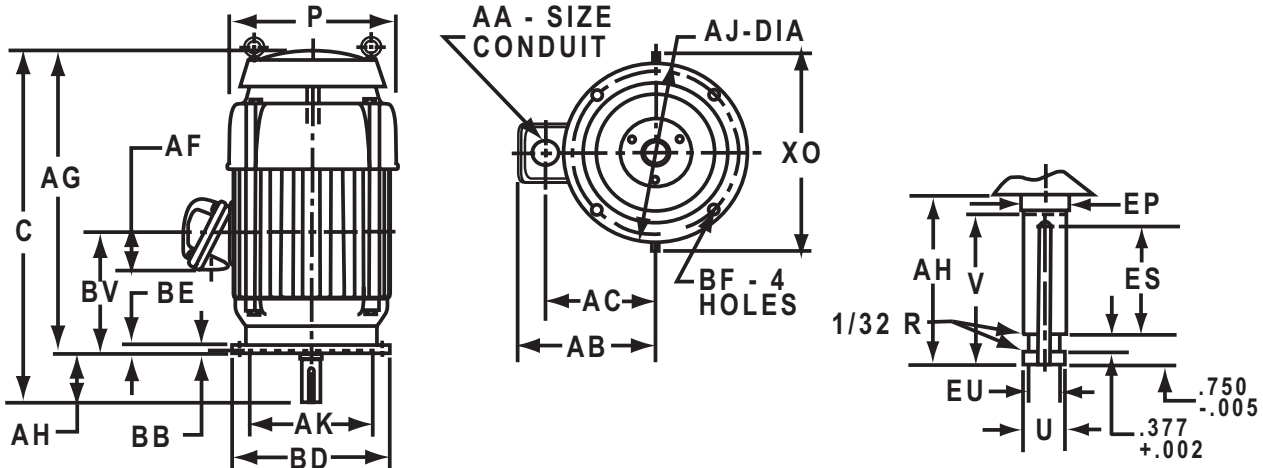

ALL DIMENSIONS ARE IN INCHES

FRAME	AF	AG	BE	BV	XO
143, 145HP	1.75	12.63	0.562	6.812	---
182, 184HP	2.25	16.593	0.593	7.625	11.625
213, 215HP	2.625	20.50	0.75	8	---
254, 256VP, HPH	3.125	24.812	0.593	10	---
284, 286HP, HPA, HPH	3.875	27.375	0.906	11.187	---
284, 286HPZ, HPAZ, HPHZ	3.875	27.375	0.906	11.187	---

FRAME	C	P ³	T	AA	AB	AC
143, 145HP	15.38	7.75	---	0.75	7.63	6
182, 184HP	19.343	9.50	---	0.75	7.625	5.75
213, 215HP	23.25	11.062	1.562	1	9.062	6.812
254, 256HP, HPH	27.562	13.187	1.625	1.50	11.06	8.25
284, 286HP, HPA, HPH	30.125	14.562	1.50	2	13.125	9.625
284, 286HPZ, HPAZ, HPHZ	31.875	14.562	1.50	2	13.125	9.625

FRAME	U ²	V MIN	AH ± .031	AJ	AK	BB MIN	BD	BF	EP MIN	ES MIN	EU -.005	SQ KEY
143, 145HP	0.875	2.75	2.75	9.125	8.25	0.187	10	0.437	1.156	1.28	0.687	0.187
182, 184HP	1.125	2.75	2.75	9.125	8.25	0.187	10	0.437	1.156	1.25	0.875	0.25
213, 215HP	1.125	2.75	2.75	9.125	8.25	0.187	10	0.437	1.375	1.25	0.875	0.25
254, 256HP	1.125	2.75	2.75	9.125	8.25	0.187	10	0.437	1.75	1.25	0.875	0.25
254, 256HPH	1.125	2.75	2.75	9.125	8.25	0.187	12	0.437	1.75	1.25	0.875	0.25
284, 286HP	1.125	2.75	2.75	9.125	8.25	0.187	10	0.437	1.75	1.312	0.875	0.25
284, 286HPA	1.125	2.75	2.75	9.125	8.25	0.187	12	0.437	1.75	1.312	0.875	0.25
284, 286HPH	1.125	2.75	2.75	14.75	13.50	0.25	16.50	0.687	1.75	1.312	0.875	0.25
284, 286HPZ	1.625	4.50	4.50	9.125	8.25	0.187	10	0.437	1.75	3.062	1.25	0.375
284, 286HPAZ	1.625	4.50	4.50	9.125	8.25	0.187	12	0.437	1.75	3.062	1.25	0.375

- ALL ROUGH CASTING DIMENSIONS MAY VARY BY .25" DUE TO CASTING VARIATIONS.
- SHAFT EXTENSION DIAMETER TOLERANCE: +.0000; -.005 UP 1-1/2" INCLUSIVE. LARGE DIAMETERS: +.001; -.001.
- LARGEST MOTOR WIDTH
- CONDUIT OPENING MAY BE LOCATED IN STEPS OF 90°. STANDARD AS SHOWN WITH CONDUIT OPENING DOWN.

TOLERANCES	8-1/4 AK	13.5 A.K.
FACE RUNOUT	.004 T.I.R.	.006 T.I.R.
PERMISSIBLE ECCENTRICITY OF MOUNTING RABBET	.004 T.I.R.	.006 T.I.R.
PERMISSIBLE SHAFT RUNOUT	.002 T.I.R.	.002 T.I.R.
"AK" DIMENSION	+.000; -.003	+.000; -.005



† All marks shown within this document are properties of their respective owners.

DIMENSIONS
HAZARDOUS LOCATION
SOLID SHAFT
FRAME: 143VP - 286VPZ

TYPES: LV & LVE

PRINTS
143-286
LV, LVE

Typical Dimensions For Reference Only

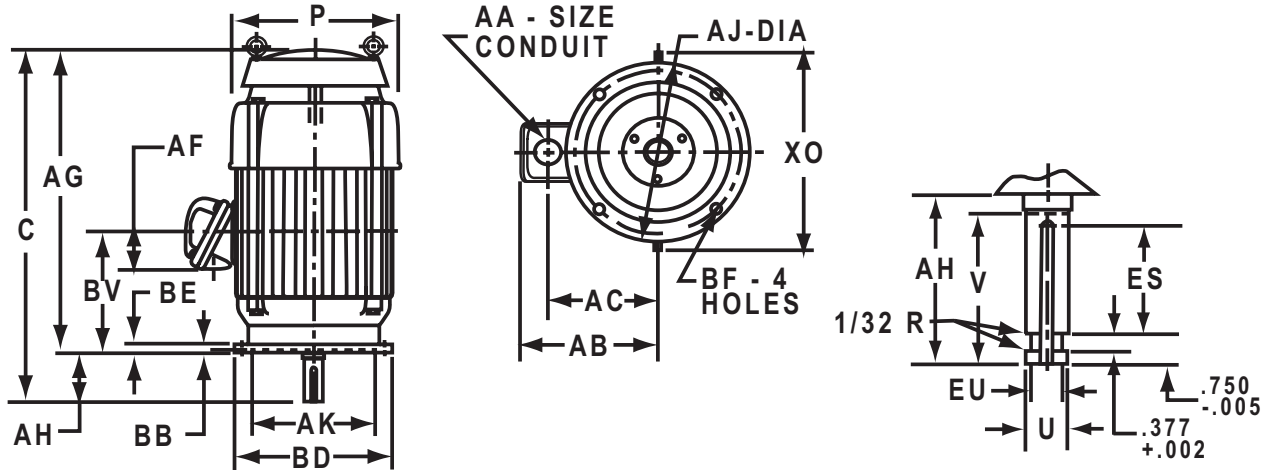

ALL DIMENSIONS ARE IN INCHES

FRAME	AF	AG	BE	BV	XO
143, 145VP	1.75	12.312	0.562	6.812	-
182, 184VP	2.25	16.593	0.593	7.625	11.625
213, 215VP	2.625	20.50	0.75	8	---
254, 256VP, VPH	3.125	24.812	0.593	10	---
284, 286VP, VPA, VPH	3.875	27.375	0.906	11.187	---
284, 286VPZ, VPAZ, VPHZ	3.875	27.375	0.906	11.187	---

FRAME	C	P ¹	T	AA	AB	AC
143, 145VP	15.38	7.75	---	0.75	7.63	6
182, 184VP	19.343	9.50	---	0.75	7.625	5.75
213, 215VP	23.25	11.062	1.312	1	9.062	6.812
254, 256VP, VPH	27.562	13.187	1.625	1.50	11.06	8.25
284, 286VP, VPA, VPH	30.125	14.562	1.50	2	13.125	9.625
284, 286VPZ, VPAZ, VPHZ	31.875	14.562	1.50	2	13.125	9.625

FRAME	U ²	V MIN	AH ± .062	AJ	AK	BB MIN	BD	BF	ES MIN	EU -.005	SQ KEY
143, 145VP	0.875	2.75	2.75	9.125	8.25	0.187	10	0.437	1.28	0.687	0.187
182THRU 256VP	1.125	2.75	2.75	9.125	8.25	0.187	10	0.437	1.25	0.875	0.25
254, 256VPH	1.125	2.75	2.75	9.125	8.25	0.187	12	0.437	1.25	0.875	0.25
284, 286VP	1.125	2.75	2.75	9.125	8.25	0.187	10	0.437	1.312	0.875	0.25
284, 286VPA	1.125	2.75	2.75	9.125	8.25	0.187	12	0.437	1.312	0.875	0.25
284, 286VPH	1.125	2.75	2.75	14.75	13.25	0.25	16.5	0.687	1.312	0.875	0.25
284, 286VPZ	1.625	4.50	4.50	9.125	8.25	0.187	10	0.437	3.312	1.25	0.375
284, 286VPAZ	1.625	4.50	4.50	9.125	8.25	0.187	12	0.437	3.062	1.25	0.375
284, 286VPHZ	1.625	4.50	4.50	14.75	13.25	0.25	16.5	0.687	3.062	1.25	0.375

- ALL ROUGH CASTING DIMENSIONS MAY VARY BY 1/4" DUE TO CASTING VARIATIONS.
- SHAFT EXTENSION DIAMETER TOLERANCE: +.0000; -.005 UP 1-1/2" INCLUSIVE. LARGE DIAMETERS: +.001; -.001.
- LARGEST MOTOR WIDTH
- CONDUIT OPENING MAY BE LOCATED IN STEPS OF 90°. STANDARD AS SHOWN WITH CONDUIT OPENING DOWN.

TOLERANCES	8-1/4 AK	13.5 A.K.
FACE RUNOUT	.004 T.I.R.	.007 T.I.R.
PERMISSIBLE ECCENTRICITY OF MOUNTING RABBET	.004 T.I.R.	.007 T.I.R.
PERMISSIBLE SHAFT RUNOUT	.002 T.I.R.	.002 T.I.R.
*AK" DIMENSION	+0.00; -.003	+0.00; -.005



DIMENSIONS
HAZARDOUS LOCATION
SOLID SHAFT
FRAME: 324HP - 447HP

TYPES: LV & LVE

PRINTS
324-447
LV, LVE

Typical Dimensions For Reference Only

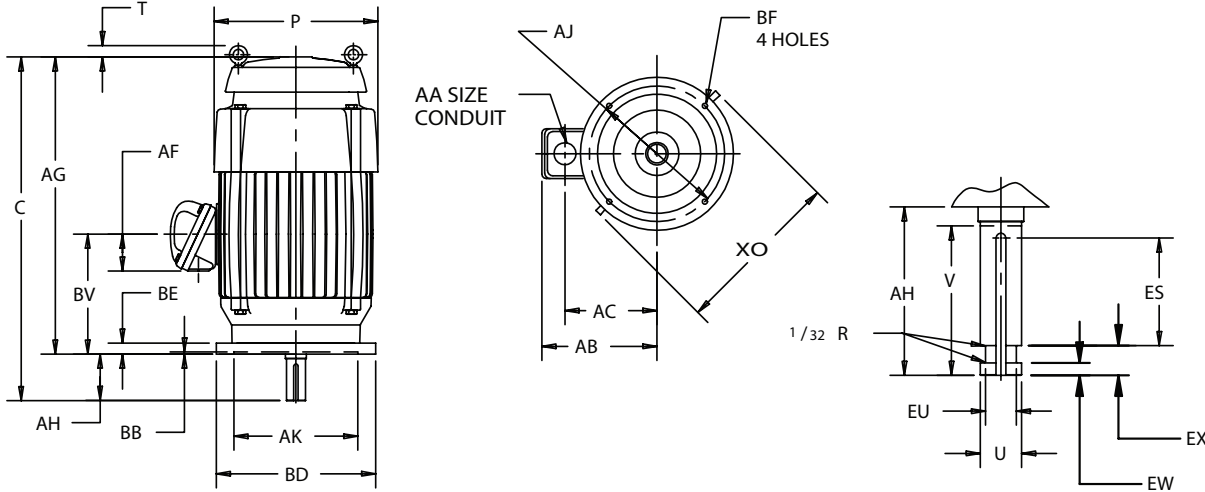

ALL DIMENSIONS ARE IN INCHES

BASIC FRAME	C	P ²	T	V ³ MIN	AA	AG	AH ± .031	AJ
324, 326HP	34.687	17	0.875	4.50	2	30.187	4.50	14.75
364, 365	36.75	18.75	1.312	4.50	3	32.25	4.50	14.75
404, 405	42.437	21.187	---	4.50	3	37.937	4.50	14.75
444, 445	46.187	23.25	---	4.50	3	41.687	4.50	14.75
447	49.687	23.25	---	4.50	3	45.187	4.50	14.75

BASIC FRAME	AK	BB MIN	BD	BF	BV	XO
324, 326HP	13.50	0.25	16.50	0.687	11.312	---
364, 365	13.50	0.25	16.50	0.687	13	---
404, 405	13.50	0.25	16.50	0.687	15.625	24.125
444, 445	13.50	0.25	16.50	0.687	16.50	26.25
447	13.50	0.25	16.50	0.687	18.25	26.25

FRAME	U ⁴	AB	AC	AF	BE	EP MIN	ES MIN	EU -.005	SQ KEY
364, 365HP	1.625	17.56	12.25	4.562	1	2.25	3.03	1.25	0.375
364, 365HPZ	2.125	17.56	12.25	4.562	1	2.25	3.03	1.75	0.50
404, 405	1.625	18.81	13.75	4.562	1	2.25	3.03	1.25	0.375
404, 405	2.125	18.81	13.75	4.562	1	2.25	3.03	1.75	0.50
444, 445	2.125	19.75	14.625	4.562	1.125	2.25	3	1.75	0.50
447	2.125	19.75	14.625	4.562	1.125	2.25	3	1.75	0.50

TOLERANCES	8.25 AK	13.50 A.K.
"AK" DIMENSION	.004; -.000	.006; -.000
FACE RUNOUT	.004 T.I.R.	.006 T.I.R.
PERMISSIBLE ECCENTRICITY OF MOUNTING RABBET	.004 T.I.R.	.006 T.I.R.
PERMISSIBLE SHAFT RUNOUT	.002 T.I.R.	.002 T.I.R.

1. ALL ROUGH CASTING DIMENSIONS MAY VARY BY 1/4" DUE TO CASTING VARIATIONS.
2. LARGEST MOTOR WIDTH
3. CONDUIT OPENING MAY BE LOCATED IN STEPS OF 90° STANDARD AS SHOWN WITH CONDUIT OPENING DOWN.
4. SHAFT EXTENSION DIAMETER TOLERANCE: +.0000; -.005 UP

† All marks shown within this document are properties of their respective owners.



DIMENSIONS
HAZARDOUS LOCATION
SOLID SHAFT
FRAME: 324VP - 447VP

TYPES: LV & LVE

PRINTS
324-447
LV, LVE

Typical Dimensions For Reference Only

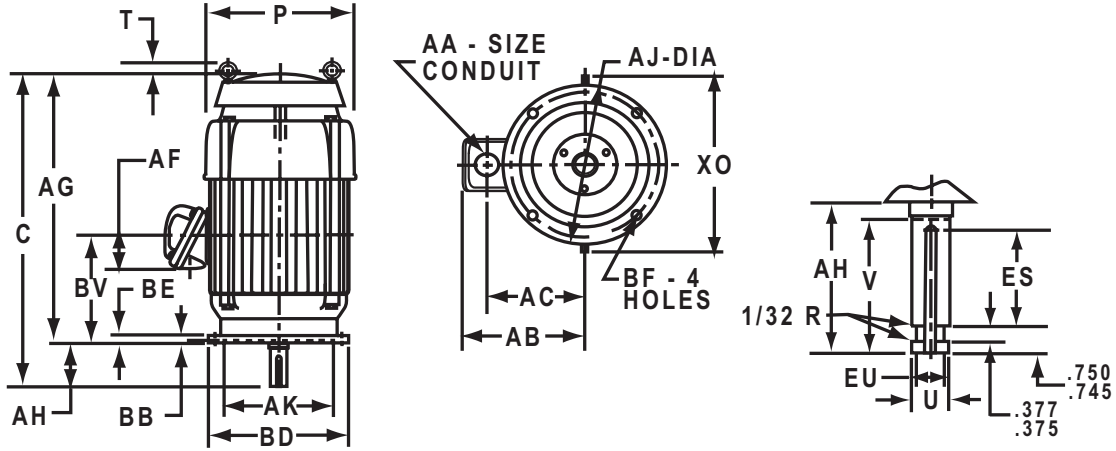

ALL DIMENSIONS ARE IN INCHES

BASIC FRAME	C	P ²	T	V ³ MIN	AA	AG	AH ±.062	AJ
324, 326VP	34.687	17	0.875	4.50	2	30.187	4.50	14.75
324, 326VPH	34.687	17	0.875	4.50	2	30.187	4.50	9.125
364, 365	36.75	18.75	1.312	4.50	3	32.25	4.50	14.75
404, 405	42.437	21.187	---	4.50	3	37.937	4.50	14.75
444, 445	46.187	23.25	---	4.50	3	41.687	4.50	14.75
447	49.687	23.25	---	4.50	3	45.187	4.50	14.75

BASIC FRAME	AK	BB MIN	BD	BF	BV	XO
324, 326VP	13.50	0.25	16.50	0.687	11.94	---
324, 326VPH	8.25	0.187	12	0.437	11.94	---
364, 365	13.50	0.25	16.50	0.687	13	---
404, 405	13.50	0.25	16.50	0.687	13	24.125
444, 445	13.50	0.25	16.50	0.687	16.50	26.25
447	13.50	0.25	16.50	0.687	18.25	26.25

FRAME	U -.001	AB	AC	AF	BE	ES MIN	EU -.005	SQ KEY
324, 326VP, VPH	1.625	15.88	11.25	3.875	1	3.03	1.25	0.375
364, 365VP	1.625	17.56	12.25	4.56	1	3.03	1.25	0.375
364, 365VPZ	2.125	17.56	12.25	4.56	1	3.03	1.75	0.50
404, 405VP	1.625	18.81	13.75	4.56	1	3.03	1.25	0.375
404, 405VPZ	2.125	18.81	13.75	4.56	1	3.03	1.75	0.50
444, 445, 447VP	2.125	19.75	14.625	4.562	1.125	3.03	1.75	0.50

TOLERANCES	8.25 AK	13.50 A.K.
"AK" DIMENSION	.003; -.000	.005; -.000
FACE RUNOUT	.004 T.I.R.	.007 T.I.R.
PERMISSIBLE ECCENTRICITY OF MOUNTING RABBET	.004 T.I.R.	.007 T.I.R.
PERMISSIBLE SHAFT RUNOUT	.002 T.I.R.	.002 T.I.R.

- 1: ALL ROUGH CASTING DIMENSIONS MAY VARY BY 1/4" DUE TO CASTING VARIATIONS.
- 2: LARGEST MOTOR WIDTH
- 3: CONDUIT OPENING MAY BE LOCATED IN STEPS OF 90°. STANDARD AS SHOWN WITH CONDUIT OPENING DOWN.

† All marks shown within this document are properties of their respective owners.



DIMENSIONS
TOTALLY ENCLOSED FAN COOLED
SOLID SHAFT
FRAME: 182VP - 286VPHZ

TYPES: TV-4 & TVE-4

PRINTS
182-286
TV-4, TVE-4

Typical Dimensions For Reference Only

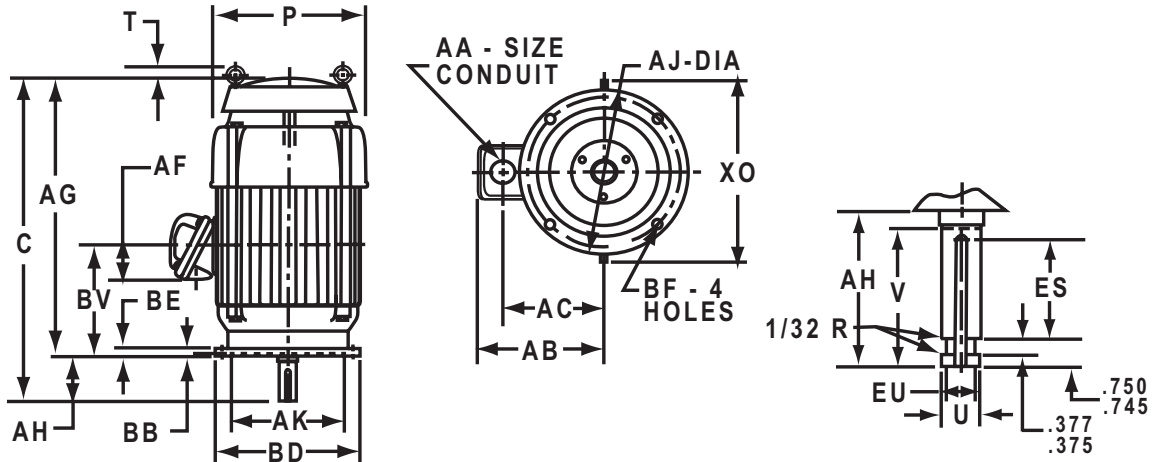

ALL DIMENSIONS ARE IN INCHES

FRAME	C	P ²	T	U -.005	V MIN	AA	AB	AC	AF
182, 184 VP	18.19	9.5	---	1.125	2.75	1	7.31	6.16	2.63
213, 215VP	21.50	11.13	1.31	1.125	---	1	7.88	6.63	3.19
254, 256VP, VPH	27.38	13.38	---	1.125	2.75	1.25	10.25	7.88	2.03
284, 286VP, VPA, VPH	30.88	13.38	---	1.125	2.75	1.50	11.07	8.31	2.59
284, 286VPZ, VPAZ, VPHZ	32.63	13.38	---	1.625	4.50	1.50	11.07	8.31	2.59

FRAME	AG	AH ±.062	BE	BV	ES MIN	EU -.005	XO	SQ KEY
182, 184 VP	15.44	2.75	.750	6.50	1.28	.875	11.94	.25
213, 215 VP	19.44	2.75	.750	8	1.25	.875	---	.25
254, 256 VP, VPH	24.63	2.75	1	13.81	1.25	.875	15.50	.25
284, 286 VP, VPA, VPH	28.13	2.75	1	16.19	1.31	.875	15.88	.25
284, 286 VPZ, VPAZ, VPHZ	28.13	4.50	1	14.75	3.06	1.250	15.88	.375

FRAME	AJ	AK	BB	BD	BF
182, 184 VP	9.125	8.25	.25	10	.44
213, 215 VP 254, 256 VP	9.125	8.25	.19	10	.44
254, 256 VPH, 284, 286 VPA, VPAZ	9.125	8.25	.19	12	.44
284, 286 VP, VPZ	9.125	8.25	.19	10	.44
284, 286 VPH, VPHZ	14.750	13.50	.25	16.50	.69

TOLERANCES	8.25 AK	13.50 AK
"AK" DIMENSION	+.003; -.000	+.005; -.000
FACE RUNOUT	.004 T.I.R.	.007 T.I.R.
PERMISSIBLE ECCENTRICITY OF MOUNTING RABBET	.004 T.I.R.	.007 T.I.R.
PERMISSIBLE SHAFT RUNOUT	.002 T.I.R.	.002 T.I.R.

- 1: ALL ROUGH CASTING DIMENSIONS MAY VARY BY 1/4" DUE TO CASTING VARIATIONS.
- 2: SHAFT EXTENSION DIAMETER TOLERANCE: +.0000; -.0005 UP 1-1/2" INCLUSIVE. LARGE DIAMETERS: +.000; -.001.
3. LARGEST MOTOR WIDTH.
4. CONDUIT OPENING MAY BE LOCATED IN STEPS OF 90°. STANDARD AS SHOWN WITH CONDUIT OPENING DOWN.

† All marks shown within this document are properties of their respective owners.



DIMENSIONS
TOTALLY ENCLOSED FAN COOLED
SOLID SHAFT
FRAME: 324VP - 447VPA

TYPES: TV-4, TVE-4, TVI-4 & TVS-4

PRINTS
324-447
TV-4, TVE-4
TVI-4, TVS-4

Typical Dimensions For Reference Only

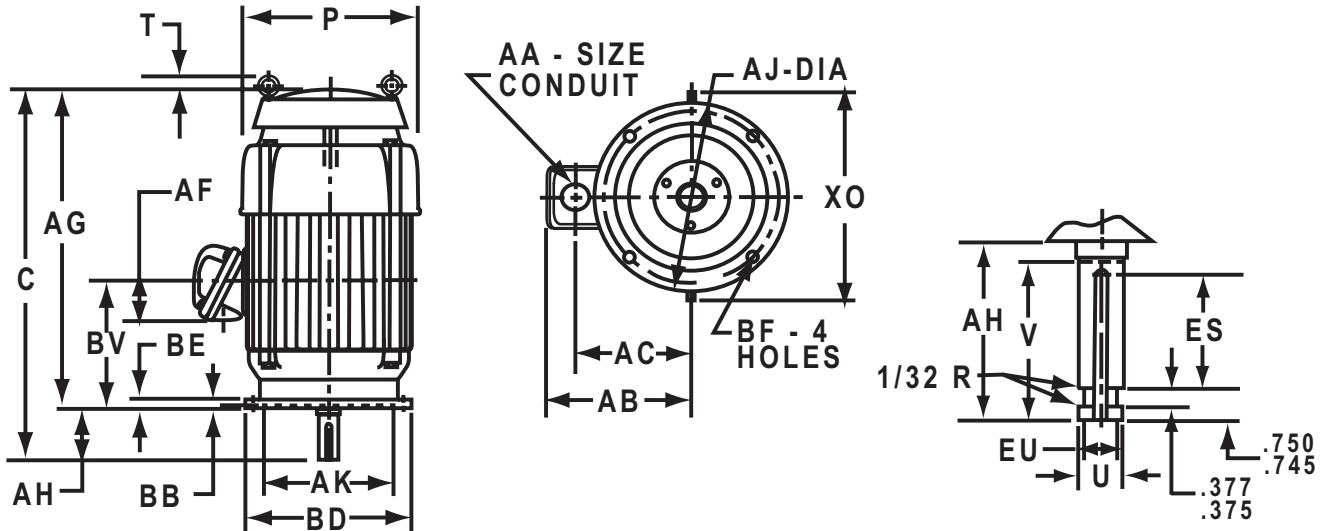

ALL DIMENSIONS ARE IN INCHES

BASIC FRAME	C	P ²	T	U -.001	V MIN	AA	AB	AC	AF
324, 326	34.687	17	0.875	1.625	4.5	2	13.88	10.63	3.25
364, 365	36.75	18.75	1.312	1.625	4.5	3	16.25	12.03	3.38
404, 405	42.437	21.50	---	1.625	4.5	3	17.50	13.31	3.38
444, 445	52.625	23.25	---	2.125	4.562	3	18.03	14.88	4.72
447	56.125	23.25	---	2.125	4.562	3	18.03	14.88	4.72

BASIC FRAME	AG	AH ± .062	BE	BV	ES MIN	EU EU -.005	XO	SQ KEY
324, 326	30.187	4.5	1	11.937	3.03	1.25	---	0.375
364, 365	32.25	4.5	1	13	3	1.25	---	0.375
404, 405	46	4.5	1	15.625	3.03	1.25	24.66	0.375
444, 445	47.56	4.5	1	16.50	3.03	1.75	26.25	1/2
447	51.06	4.5	1	18.25	3.03	1.75	26.25	1/2

FRAME	AJ	AK	BB	BD	BF
324, 326VPH	9.125	8.25	0.187	12	0.437
324, 326, 364, 365, 404VP; 405, 444, 445, 447VP	14.75	13.5	0.25	16.5	0.687
404, 405, 444, 445, 447VPA	14.75	13.5	0.25	20	0.687

TOLERANCES	8.25 AK	13.50 AK
"AK" DIMENSION	+ .003; - .000	+ .005; - .000
FACE RUNOUT	.004 T.I.R.	.007 T.I.R.
PERMISSIBLE ECCENTRICITY OF MOUNTING RABBET	.004 T.I.R.	.007 T.I.R.
PERMISSIBLE SHAFT RUNOUT	.002 T.I.R.	.003 T.I.R.

- ALL ROUGH CASTING DIMENSIONS MAY VARY BY 1/4" DUE TO CASTING VARIATIONS.
- LARGEST MOTOR WIDTH.
- CONDUIT OPENING MAY BE LOCATED IN STEPS OF 90°. STANDARD AS SHOWN WITH CONDUIT OPENING DOWN.

† All marks shown within this document are properties of their respective owners.



DIMENSIONS
HAZARDOUS LOCATION
SOLID SHAFT
FRAME: 182VP - 286VPHZ

TYPES: LV-4, LVE-4

PRINTS
182-286
LV-4, LVE-4

Typical Dimensions For Reference Only

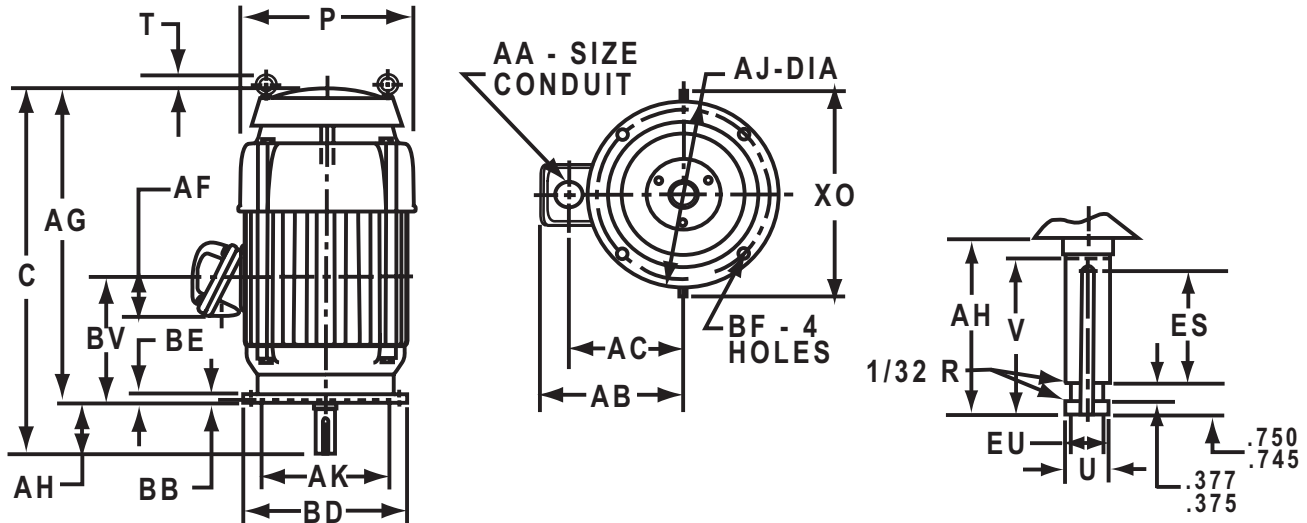

ALL DIMENSIONS ARE IN INCHES

BASIC FRAME	C	P ³	T	U	V MIN	AA	AB	AC	AF
182, 184	19.343	9.5	---	1.125	2.75	0.75	7.625	5.81	2.25
213, 215	23.25	11.062	1.312	1.125	2.75	1	9.19	6.812	2.625
254, 256	27.562	13.187	1.625	1.125	2.75	1.5	10.5	7.937	3.125
284, 286VP, VPA, VPH	30.125	14.562	1.5	1.125	2.75	2	13.125	9.625	3.875
284, 286VPZ, VPAZ, VPHZ	31.875	14.562	1.5	1.625	4.5	2	13.125	9.625	3.875

BASIC FRAME	AG	AH ±.062	BE	BV	ES MIN	EU -.005	XO	SQ KEY
182, 184	16-19/32	2.75	0.75	7.625	1.28	0.875	11.94	0.25
213, 215	20.5	2.75	0.75	8	1.25	0.875	---	0.25
254, 256	24-13/16	2.75	19/32	10	1.25	0.875	---	0.25
284, 286VP, VPA, VPH	27.375	2.75	29/32	11.187	1.25	0.875	---	0.25
284, 286VPZ, VPAZ, VPHZ	27.375	4.5	29/32	11.187	3	1.25	---	0.375

FRAME	AJ	AK	BB	BD	BF
182, 184VP; 213, 215VP; 254, 256VP; 284, 286VP, VPZ	9.125	8.25	0.187	10	0.437
254, 256VPH; 284, 286VPA, VPAZ	9.125	8.25	0.187	12	0.437
284, 286VPH, VPHZ	14.75	13.5	0.25	16.5	0.687

TOLERANCES	8.25 AK	13.50 AK
"AK" DIMENSION	+ .003; -.000	+ .005; -.000
FACE RUNOUT	.004 T.I.R.	.007 T.I.R.
PERMISSIBLE ECCENTRICITY OF MOUNTING RABBET	.004 T.I.R.	.007 T.I.R.
PERMISSIBLE SHAFT RUNOUT	.002 T.I.R.	.002 T.I.R.

- 1: ALL ROUGH CASTING DIMENSIONS MAY VARY BY 1/4" DUE TO CASTING VARIATIONS.
- 2: SHAFT EXTENSION DIAMETER TOLERANCE: +.0000; -.0005 UP 1-1/2" INCLUSIVE. LARGE DIAMETERS: +.000; -.001.
- 3: LARGEST MOTOR WIDTH.
- 4: CONDUIT OPENING MAY BE LOCATED IN STEPS OF 90°. STANDARD AS SHOWN WITH CONDUIT OPENING DOWN.

† All marks shown within this document are properties of their respective owners.



DIMENSIONS
HAZARDOUS LOCATION
SOLID SHAFT
FRAME: 324VP - 447VPA

TYPES: LV-4 & LVE-4

PRINTS
324 - 447
LV-4, LVE-4

Typical Dimensions For Reference Only

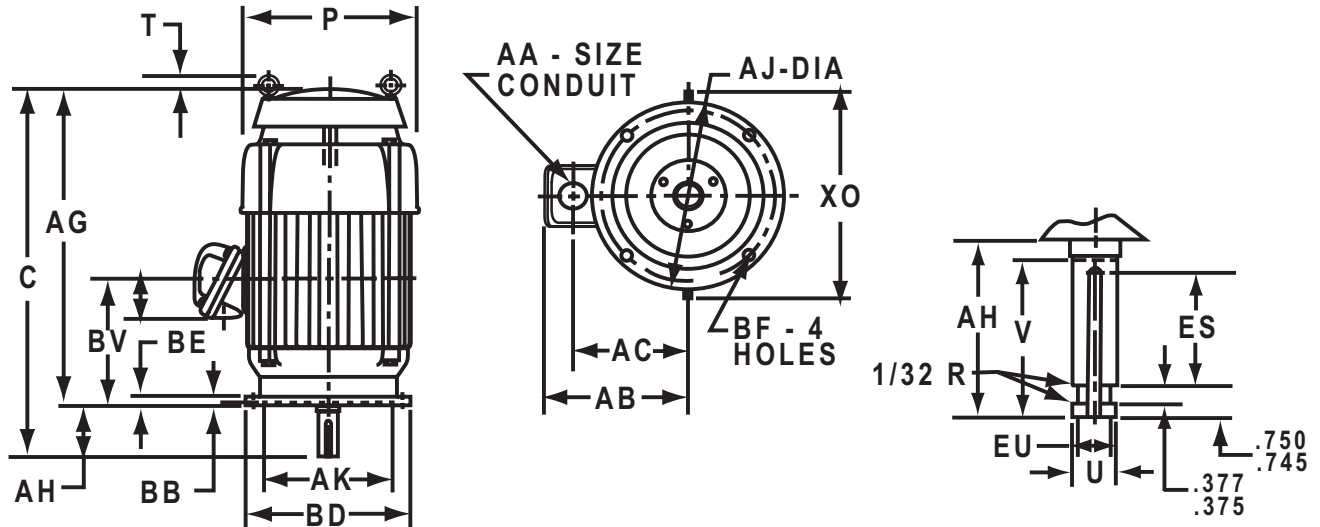

ALL DIMENSIONS ARE IN INCHES

FRAME	AJ	AK	BB	BD	BF
324, 326VPH	9.125	8.25	0.187	12	0.437
324, 326, 364, 404VP 405, 444, 445, 447VP	14.75	13.5	0.25	16/12	0.687
B365, 404, 405, 444, 445, 447VPA	14.75	13.5	0.25	20	0.687

BASIC FRAME	AG	AH ±.062	BE	BV	ES MIN	EU	EU -.005	XO	SQ KEY
324, 326	30.187	4.5	1	11.937	3.03	1.25	---	---	0.375
364, 365	32.25	4.5	1	13	3.03	1.25	---	---	0.375
404, 405	46.44	4.5	1	15.625	3.03	1.25	24.125	24.125	0.375
444, 445	47.56	4.5	1	16.50	3.03	1.75	28.94	28.94	0.5
447	51.06	4.5	1	18.50	3.03	1.75	28.94	28.94	0.5

BASIC FRAME	C	P 2	T	U -.001	V MIN	AA	AB	AC	AF
324, 326	34.687	17	0.875	1.625	4.5	2	15.88	11.25	3.875
364, 365	36.75	18.75	1.312	1.625	4.5	3	17.56	12.25	4.56
404, 405	50.19	21.187	---	1.625	4.5	3	18.81	13.75	4.56
444, 445	52.625	23.25	---	2.125	4.562	3	19.875	14.625	4.562
447	56.125	23.25	---	2.125	4.562	3	19.875	14.625	4.562

TOLERANCES	8.25 AK	13.50 AK
"AK" DIMENSION	+.003; -.000	+.005; -.000
FACE RUNOUT	.004 T.I.R.	.007 T.I.R.
PERMISSIBLE ECCENTRICITY OF MOUNTING RABBET	.004 T.I.R.	.007 T.I.R.
PERMISSIBLE SHAFT RUNOUT	.002 T.I.R.	.002 T.I.R.

1. ALL ROUGH CASTING DIMENSIONS MAY VARY BY 1/4" DUE TO CASTING VARIATIONS.
2. LARGEST MOTOR WIDTH.
3. CONDUIT OPENINGS MAY BE LOCATED IN STEPS OF 90°. STANDARD AS SHOWN WITH CONDUIT OPENING DOWN.

† All marks shown within this document are properties of their respective owners.



DIMENSIONS
TOTALLY ENCLOSED FAN COOLED
SOLID SHAFT
FRAME: 182LP - 286HPHA

TYPES: TV-9, TVE-9 & TVI-9

PRINTS
182 - 286
TV-9, TVE-9
TVI-9

Typical Dimensions For Reference Only

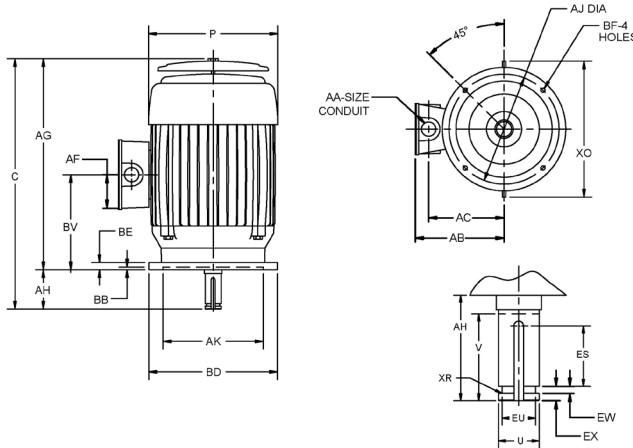

ALL DIMENSIONS ARE IN INCHES

BASIC FRAME	C	P ⁴	T	AA	AB	AC
182, 184	18.19	9.5	---	1	7.31	6.16
213, 215	21.50	11.125	---	1	7.86	6.61
254, 256	26.875	13.277	---	1.25	10.25	7.88
284, 286	32.625	13.375	---	1.5	11.07	8.32

BASIC FRAME	AF	AG	AH ±.031	BE	BV	XO
182, 184	2.625	15.437	2.75	.75	6.5	11.94
213, 215	3.312	18.75	2.75	0.75	8	13.50
254, 256	2.03	24.125	2.75	1	10.437	13.50
284, 286	2.562	28.125	4.5	1	14.75	15.875

FRAME	U ²	V MIN	AJ	AK	BB MIN	BD	BF	ES MIN	EU -.005	SQ KEY
182, 184HP, LP	1.125	2.75	9.125	8.25	0.25	10	0.437	1.28	0.875	0.25
213, 215HP 254, 256HP	1.125	2.75	9.125	8.25	0.187	10	0.437	1.25	0.875	0.25
213, 215LP 254, 256LP	1.625	2.75	9.125	8.25	0.187	10	0.437	1.25	1.25	0.375
254, 256HPH	1.125	2.75	9.125	8.25	0.187	12	0.437	1.28	0.875	0.25
284, 286LP	2.125	4	9.125	8.25	0.187	10	0.437	3.062	1.75	0.5
284, 286HPH	1.625	4.5	14.75	13.5	0.25	16.5	0.687	3.062	1.25	0.375
284, 286LPH	2.125	4	14.75	13.5	0.25	16.5	0.687	3.062	1.75	0.5
284, 286HPZ	1.625	4.5	9.125	8.25	0.187	10	0.437	3.062	1.25	0.375
284, 286HPHA	1.625	4.5	9.125	8.25	0.187	12	0.437	3.062	1.25	0.375

TOLERANCES	8.25 AK	13.50 AK
"AK" DIMENSION	+ .003; - .000	+ .005; - .000
FACE RUNOUT	.004 T.I.R.	.004 T.I.R.
PERMISSIBLE ECCENTRICITY OF MOUNTING RABBET	.004 T.I.R.	.004 T.I.R.
PERMISSIBLE SHAFT RUNOUT	.001 T.I.R.	.001 T.I.R.
PERMISSIBLE SHAFT ENDPLAY	.0015 MAX	.0015 MAX

- 1: ALL ROUGH CASTING DIMENSIONS MAY VARY BY .25" DUE TO CASTING VARIATIONS.
- 2: SHAFT EXTENSION DIAMETER TOLERANCE: +.0000; -.0005 UP 1-5/8" INCLUSIVE. LARGE DIAMETERS: +.000; -.001.
- 3: CONDUIT OPENINGS MAY BE LOCATED IN STEPS OF 90°. STANDARD AS SHOWN WITH CONDUIT OPENING DOWN.
- 4: LARGEST MOTOR WIDTH.

† All marks shown within this document are properties of their respective owners.



DIMENSIONS
TOTALLY ENCLOSED FAN COOLED
SOLID SHAFT
FRAME: 324HP - 447LP

TYPES: TV-9, TVE-9 & TVI-9

PRINTS
324 - 447
TV-9, TVE-9
TVI-9

Typical Dimensions For Reference Only

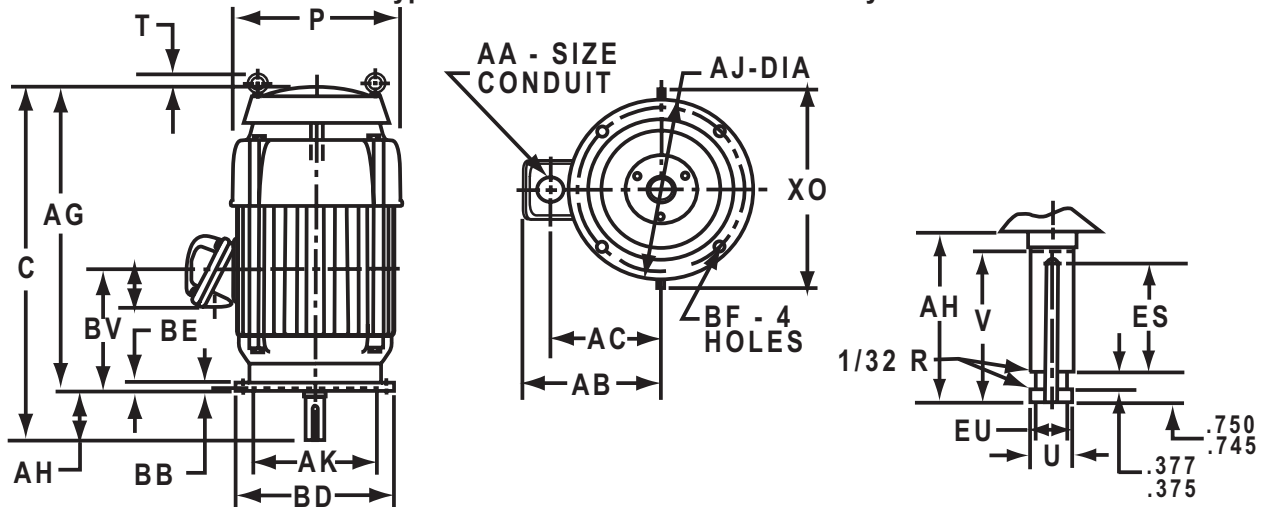

ALL DIMENSIONS ARE IN INCHES

BASIC FRAME	AF	AG	AH 3 ±.031	BE	BV	X0
324, 326	3.25	30.187	4.5	1	11.937	---
364, 365	5.28	32.25	4.5	1	13	---
404, 405	3.38	37.937	4.5	1	15.625	24.125
444, 445	4.72	41.687	4.5	1.125	16.5	26.25
447	4.72	45.187	4.5	1.125	18.25	26.25

BASIC FRAME	C	P ²	T	V MIN	AA	AB	AC
324, 326	34.687	17	0.875	4.5	2	13.88	10.63
364, 365	36.75	18.75	1.312	4.5	3.5	17	12.75
404, 405	42.437	21.187	---	4.5	3	17.50	13.375
444, 445	46.187	23.25	---	4.5	3	18.625	14.312
447	49.687	23.25	---	4.5	3	18.625	14.312

FRAME	U -.001	AJ	AK	BB MIN	BD	BF	ES MIN	EU -.005	SQ KEY
324, 326HP, 364, 365HP 405	1.625	14.75	13.5	0.25	16.5	0.687	3.03	1.25	0.375
324, 326HPH	1.625	9.125	8.25	0.187	12	0.437	3.03	1.25	0.375
324, 326LP, 364, 365LP, HPZ 404, 405LP, HPH 444, 445, 447HP, 444, 445, 447LP	2.125	14.75	13.5	0.25	16.5	0.687	3.03	1.75	0.5

TOLERANCES	8.25 AK	13.50 AK
"AK" DIMENSION	+.003; -.000	+.005; -.000
FACE RUNOUT	.004 T.I.R.	.004 T.I.R.
PERMISSIBLE ECCENTRICITY OF MOUNTING RABBIT	.004 T.I.R.	.004 T.I.R.
PERMISSIBLE SHAFT RUNOUT	.001 T.I.R.	.001 T.I.R.
PERMISSIBLE SHAFT ENDPLOY	.0015 MAX	.0015 MAX

- 1: ALL ROUGH CASTING DIMENSIONS MAY VARY BY 1/4" DUE TO CASTING VARIATIONS.
- 2: LARGEST MOTOR WIDTH.
- 3: TOLERANCE IS ± .062 ON FRAME 404 AND LARGER.
- 4: CONDUIT OPENING MAY BE LOCATED IN STEPS OF 90 DEGREES STANDARD AS SHOWN WITH CONDUIT OPENING DOWN.



† All marks shown within this document are properties of their respective owners.

DIMENSIONS
HAZARDOUS LOCATION
SOLID SHAFT
FRAME: 182LP - 286HPHA

TYPES: LV-9 & LVE-9

PRINTS
182 - 286
LV-9, LVE-9

Typical Dimensions For Reference Only

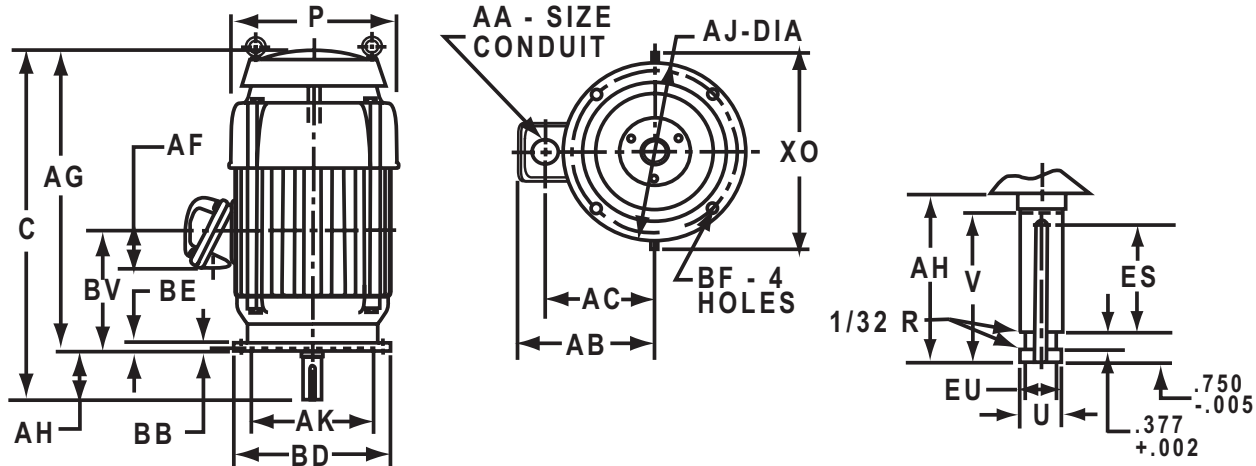

ALL DIMENSIONS ARE IN INCHES

BASIC FRAME	C	P ⁴	T	AA	AB	AC
182, 184	18.625	9.5	---	0.75	7.625	5.81
213, 215	23.25	11.125	1.312	1	9.062	6.812
254, 256	27.562	13.187	1.625	1.5	11.06	8.25
284, 286	31.875	14.562	1.5	2	13.125	9.625

BASIC FRAME	AF	AG	AH 3 ±.031	BE	BV	XO
182, 184	2.25	15.875	2.75	0.593	7.625	11.625
213, 215	2.625	20.5	2.75	0.75	8	---
254, 256	3.125	24.812	2.75	0.593	10	---
284, 286	3.875	27.375	4.5	0.906	11.187	---

FRAME	U ²	V MIN	AJ	AK	BB MIN	BD	BF	ES MIN	EU -.005	SQ KEY
182, 184HP, LP	1.125	2.75	9.125	8.25	0.187	10	0.437	1.812	0.875	0.25
213, 215HP 254, 256HP	1.125	2.75	9.125	8.25	0.187	10	0.437	1.875	0.875	0.25
213, 215LP 254, 256LP	1.625	2.75	9.125	8.25	0.187	10	0.437	1.875	1.25	0.375
254, 256HPH	1.125	2.75	9.125	8.25	0.187	12	0.437	1.875	0.875	0.25
284, 286LP	2.125	4	9.125	8.25	0.187	10	0.437	3.062	1.75	0.5
284, 286HPH	1.625	4.5	14.75	13.5	0.25	16.5	0.687	3.062	1.25	0.375
284, 286LPH	2.125	4	14.75	13.5	0.25	16.5	0.687	3.062	1.75	0.5
284, 286HPZ	1.625	4.5	9.125	8.25	0.187	10	0.437	3.062	1.25	0.375
284, 286HPHA	1.625	4.5	9.125	8.25	0.187	12	0.437	3.062	1.25	0.375

TOLERANCES	8.25 AK	13.50 AK
"AK" DIMENSION	+.003; -.000	+.005; -.000
FACE RUNOUT	.004 T.I.R.	.004 T.I.R.
PERMISSIBLE ECCENTRICITY OF MOUNTING RABBET	.004 T.I.R.	.004 T.I.R.
PERMISSIBLE SHAFT RUNOUT	.001 T.I.R.	.001 T.I.R.
PERMISSIBLE SHAFT ENDPLAY	.0015 MAX	.0015 MAX

- 1: ALL ROUGH CASTING DIMENSIONS MAY VARY BY 1/4" DUE TO CASTING VARIATIONS.
- 2: SHAFT EXTENSION DIAMETER TOLERANCE: +.0000; -.0005 UP 1-5/8" INCLUSIVE. LARGE DIAMETERS: +.000; -.001.
- 3: CONDUIT OPENING MAY BE LOCATED IN STEPS OF 90 DEGREES STANDARD AS SHOWN WITH CONDUIT OPENING DOWN.
- 4: LARGEST MOTOR WIDTH.

† All marks shown within this document are properties of their respective owners.



DIMENSIONS
HAZARDOUS LOCATION
SOLID SHAFT
FRAME: 324HP - 447LP

TYPES: LV-9 & LVE-9

PRINTS
324 - 447
LV-9, LVE-9

Typical Dimensions For Reference Only

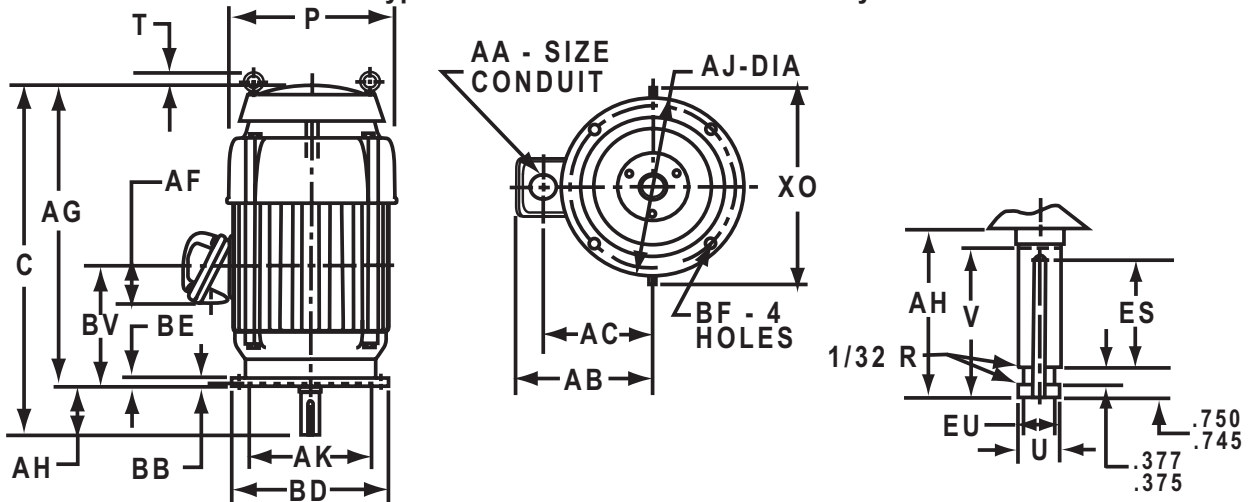

ALL DIMENSIONS ARE IN INCHES

BASIC FRAME	AF	AG	AH 3 ±.031	BE	BV	XO
324, 326	3.875	30.187	4.5	1	11.937	---
364, 365	4.56	32.25	4.5	1	13	---
404, 405	4.56	37.937	4.5	1	15.625	24.125
444, 445	4.562	41.687	4.5	1.125	16.5	28.25
447	4.562	45.187	4.5	1.125	18.25	28.25

BASIC FRAME	C	P ²	T	V MIN	AA	AB	AC
324, 326	34.687	17	0.875	4.5	2	14.187	10.687
364, 365	36.75	18.75	1.312	4.5	3	15.875	11.937
404, 405	42.437	21.187	---	4.5	3	17.125	13.187
444, 445	46.187	23.25	---	4.5	3	19.75	14.625
447	49.687	23.25	---	4.5	3	19.75	14.625

FRAME	U -.001	AJ	AK	BB MIN	BD	BF	ES MIN	EU -.005	SQ KEY
324, 326HP, 364, 365HP 405	1.625	14.75	13.5	0.25	16.5	0.687	3.03	1.25	0.375
324, 326HPH	1.625	9.125	8.25	0.187	12	0.437	3.03	1.25	0.375
324, 326LP, 364, 365LP, HPZ 404, 405LP, HPH 444, 445, 447HP, 444, 445, 447LP	2.125	14.75	13.5	0.25	16.5	0.687	3.03	1.75	0.5

TOLERANCES	8.25 AK	13.50 AK
"AK" DIMENSION	+ .003; - .000	+ .005; - .000
FACE RUNOUT	.004 T.I.R.	.004 T.I.R.
PERMISSIBLE ECCENTRICITY OF MOUNTING RABBET	.004 T.I.R.	.004 T.I.R.
PERMISSIBLE SHAFT RUNOUT	.001 T.I.R.	.001 T.I.R.
PERMISSIBLE SHAFT ENDPLAY	.0015 MAX	.0015 MAX

- 1: ALL ROUGH CASTING DIMENSIONS MAY VARY BY 1/4" DUE TO CASTING VARIATIONS.
- 2: LARGEST MOTOR WIDTH.
- 3: TOLERANCE IS ±.062 ON FRAME 404 AND LARGER.
- 4: CONDUIT OPENING MAY BE LOCATED IN STEPS OF 90 DEGREES STANDARD AS SHOWN WITH CONDUIT OPENING DOWN.



† All marks shown within this document are properties of their respective owners.

DIMENSIONS

TOTALLY ENCLOSED FAN COOLED

SOLID SHAFT

FRAME: 449VP, VPH

TYPES: JV & JV-3

PRINTS

449

JV, JV-3

Typical Dimensions For Reference Only

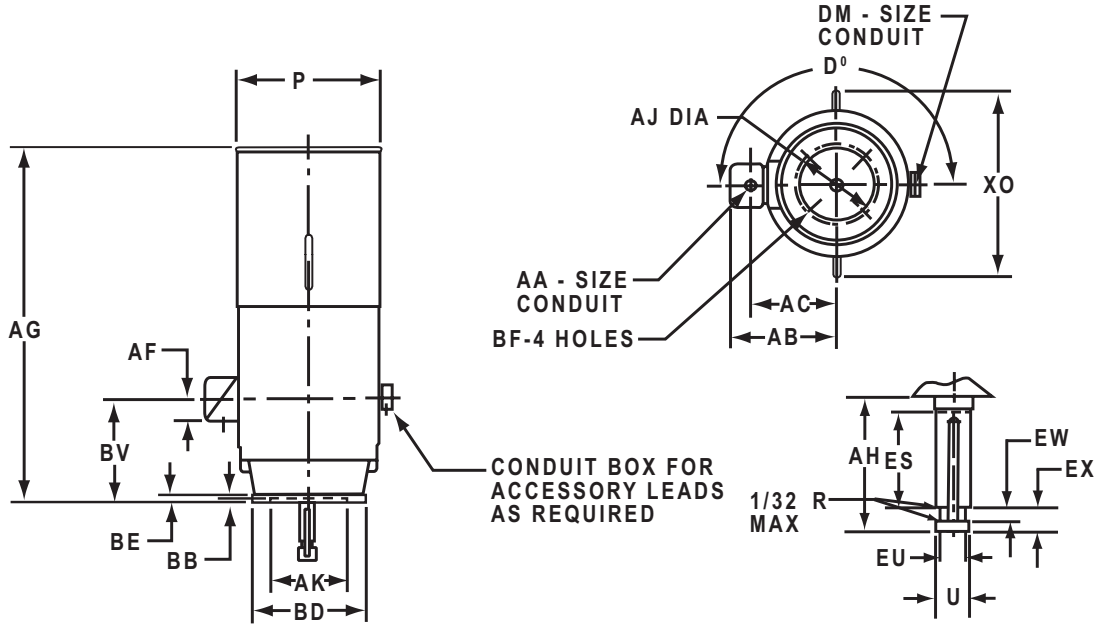

ALL DIMENSIONS ARE IN INCHES

FRAME	BD	BE	AJ	BF	AK +.005	BB	P	X0
449VP	24.5	0.875	14.75	0.687	13.500	0.25	26.25	33
449VPH	20							

FRAME	HP	VOLT	AA	AB	AC	AF	D°	DM	AG	BV
449	ALL	450	3.5	24	18.5	8.062	180	3/4	60.875	12.5
	ALL	2300								
	ALL	4000								

HP	POLES (RPM)				U	AH	ES	EU	EX	EW	SQ
	2 (3600)	4 (1800)	6 (1200)	8 (900)	-.001	±.062	MIN	-.005	-.005	+.002	KEY
HP	ALL	ALL THRU 300	ALL THRU 200	ALL THRU 150	2.125	4.500	3.000	1.750	0.750	0.375	0.5
	---	350	250 THRU 300	200	2.375	5.000	3.500	2.000	0.750	0.375	0.625
	---	---	---	250	2.625	5.000	3.500	2.250	0.750	0.375	0.625

HP	POLES (RPM)				U	AH	ES	EU	EX	EW	SQ
	10 (720)	12 (600)	14 (514)	16 (450)	-.001	±.062	MIN	-.005	-.005	+.002	KEY
HP	ALL THRU 125	ALL THRU 100	ALL THRU 75	ALL THRU 75	2.125	4.500	3.000	1.750	0.750	0.375	0.5
	150	125 THRU 150	100 THRU 125	100	2.375	5.000	3.500	2.000	0.750	0.375	0.625
	200	---	---	---	2.625	5.000	3.500	2.250	0.750	0.375	0.625

TOLERANCES	
FACE RUNOUT	.007 T.I.R.
PERMISSIBLE ECCENTRICITY OF MOUNTING RABBET	.007 T.I.R.
PERMISSIBLE SHAFT RUNOUT	.003 T.I.R.
MAXIMUM SHAFT END PLAY	.010

- ROUGH CASTING DIMENSIONS MAY VARY BY +/- 1/4" DUE TO CASTING AND/OR FABRICATION VARIATIONS.
- CONDUIT OPENING MAY BE LOCATED IN STEPS OF 90 DEGREES STANDARD IS AS SHOWN WITH CONDUIT OPENING DOWN.

† All marks shown within this document are properties of their respective owners.



**DIMENSIONS
HAZARDOUS LOCATION
SOLID SHAFT
FRAME: 5008P, PH**

TYPES: EV & EVE

**PRINTS
5008
EV, EVE**

Typical Dimensions For Reference Only

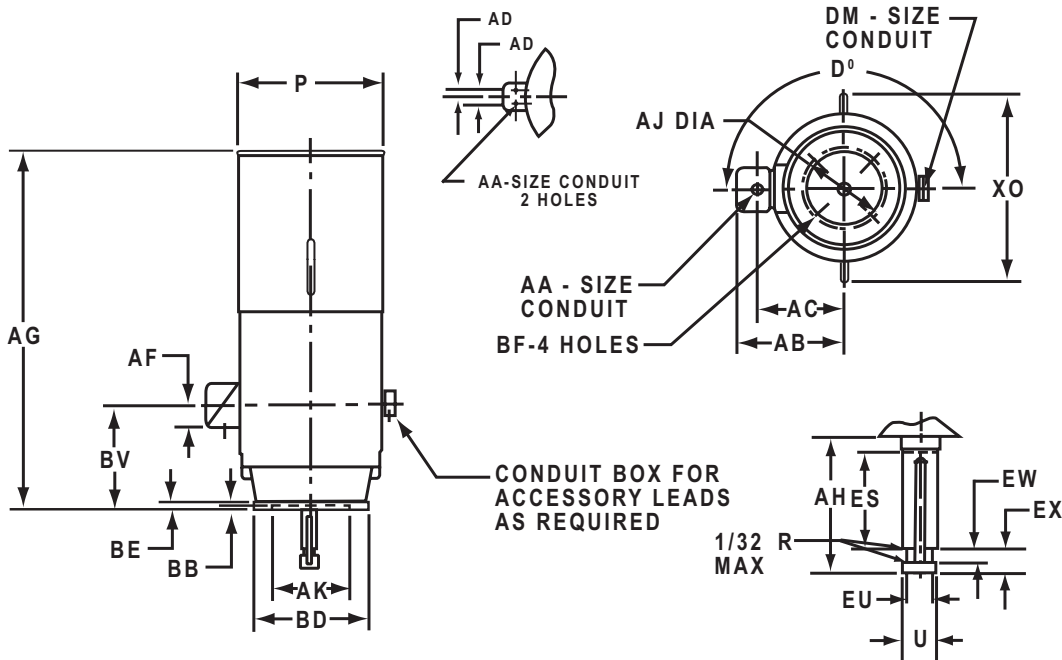

ALL DIMENSIONS ARE IN INCHES

FRAME	BD	BE	AJ	BF	AK +.005	BB	P	XO
5008P	24.5	1.25	14.75	0.687	13.500	0.25	27.5	33.625
5008PH	20							

FRAME	VOLT	AA	AB	AC	AD	AF	D°	DM	AG	BV
5008	460	3.5	24	17.312	---	5.625	158	0.75	54.562	22.937
	2300									
	4000									

HP	POLES (RPM)			U	AH	ES	EU	EX	EW	SQ
	4 (1800)	6 (1200)	8 (900)	-.001	±.062	MIN	-.005	-.005	+.002	KEY
HP	ALL THRU 300	ALL THRU 300	ALL THRU 150	2.125	4.500	3.000	1.750	0.750	0.375	0.5
	350	350	200	2.375	5.000	3.500	2.000	0.750	0.375	0.625
	---	---	250	2.625	5.000	3.500	2.250	0.750	0.375	0.625
	---	---	---	---	---	---	---	---	---	---

HP	POLES (RPM)				U	AH	ES	EU	EX	EW	SQ
	10 (720)	12 (600)	14 (514)	16 (450)	-.001	±.062	MIN	-.005	-.005	+.002	KEY
HP	ALL THRU 125	ALL THRU 100	ALL THRU 75	ALL THRU 75	2.125	4.500	3.000	1.750	0.750	0.375	0.5
	150	125 THRU 150	100 THRU 125	100	2.375	5.000	3.500	2.000	0.750	0.375	0.625
	200	---	---	---	2.625	5.000	3.500	2.250	0.750	0.375	0.625
	---	---	---	---	---	---	---	---	---	---	---

TOLERANCES	
FACE RUNOUT	.007 T.I.R.
PERMISSIBLE ECCENTRICITY OF MOUNTING RABBET	.007 T.I.R.
PERMISSIBLE SHAFT RUNOUT	.003 T.I.R.
MAXIMUM SHAFT END PLAY	.010

- ROUGH CASTING DIMENSIONS MAY VARY BY +/- 1/4" DUE TO CASTING AND/OR FABRICATION VARIATIONS.
- CONDUIT OPENING MAY BE LOCATED IN STEPS OF 90 DEGREES STANDARD IS AS SHOWN WITH CONDUIT OPENING DOWN.

† All marks shown within this document are properties of their respective owners.



DIMENSIONS

TOTALLY ENCLOSED FAN COOLED

SOLID SHAFT

FRAME: 449VP, VPH

TYPES: JV-4 & JVE-4



Typical Dimensions For Reference Only

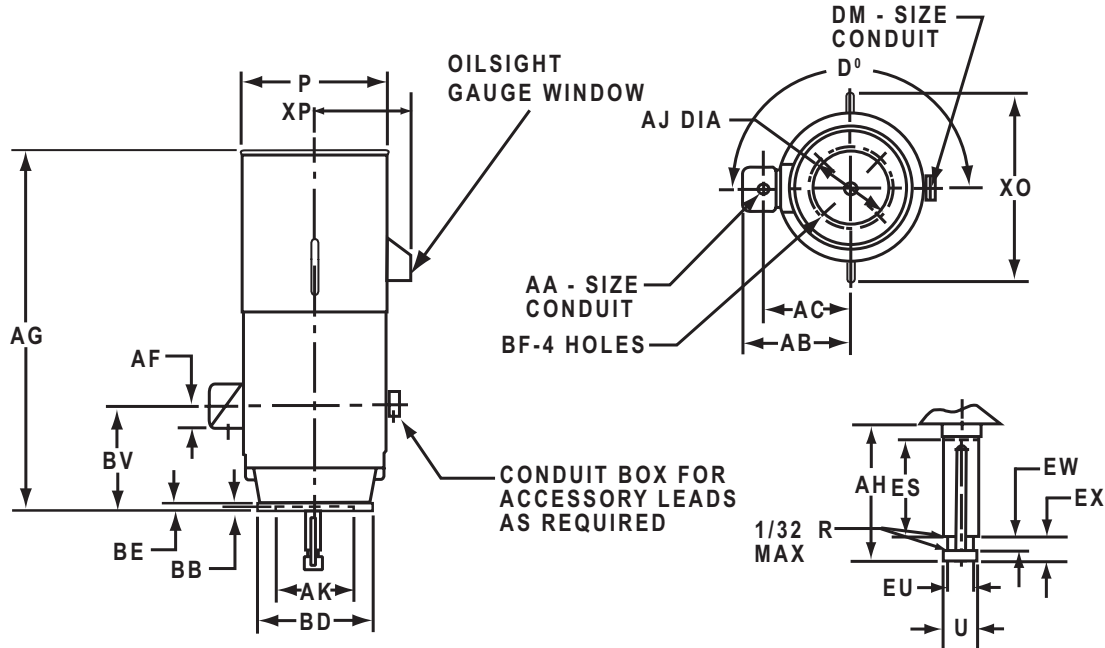

ALL DIMENSIONS ARE IN INCHES

FRAME	BD	BE	AJ	BF	AK +.005	BB	P	XO	XP
449VP	24.5	0.	14.75	0.687	13.500	0.25	26.25	33	14.5
449VPH	20								

FRAME	HP	VOLT	AA	AB	AC	AF	D°	DM	AG	BV
449	ALL	460	3.5	24	18.5	8.062	180	0.75	63.875	12.5
	ALL	2300								
	ALL	4000		25	19.5	10				

HP	POLES (RPM)				U -.001	AH ±.062	ES MIN	EU -.005	EX -.005	EW +.002	SQ KEY
	2 (3600)	4 (1800)	6 (1200)	8 (900)							
HP	ALL	ALL THRU 300	ALL THRU 200	ALL THRU 150	2.125	4.500	3.000	1.750	0.750	0.375	0.5
	---	350	ALL THRU 300	200	2.375	5.000	3.500	2.000	0.750	0.375	0.625
	---	---	---	250	2.625	5.000	3.500	2.250	0.750	0.375	0.625

HP	POLES (RPM)				U -.001	AH ±.062	ES MIN	EU -.005	EX -.005	EW +.002	SQ KEY
	10 (720)	12 (600)	14 (514)	16 (450)							
HP	ALL THRU 125	ALL THRU 100	ALL THRU 75	ALL THRU 75	2.125	4.500	3.000	1.750	0.750	0.375	0.5
	150	125 THRU 150	100 THRU 125	100	2.375	5.000	3.500	2.000	0.750	0.375	0.625
	200	---	---	---	2.625	5.000	3.500	2.250	0.750	0.375	0.625

TOLERANCES	
FACE RUNOUT	.007 T.I.R.
PERMISSIBLE ECCENTRICITY OF MOUNTING RABBIT	.007 T.I.R.
PERMISSIBLE SHAFT RUNOUT	.003 T.I.R.
MAXIMUM SHAFT END PLAY	.010

- ROUGH CASTING DIMENSIONS MAY VARY BY +/- 1/4" DUE TO CASTING AND/OR FABRICATION VARIATIONS.
- CONDUIT OPENING MAY BE LOCATED IN STEPS OF 90 DEGREES STANDARD IS AS SHOWN WITH CONDUIT OPENING DOWN.

† All marks shown within this document are properties of their respective owners.



**DIMENSIONS
HAZARDOUS LOCATION
SOLID SHAFT
FRAME: 5008P, PH**

TYPES: EV-4 & EVE-4

**PRINTS
5008
EV-4, EVE-4**

Typical Dimensions For Reference Only

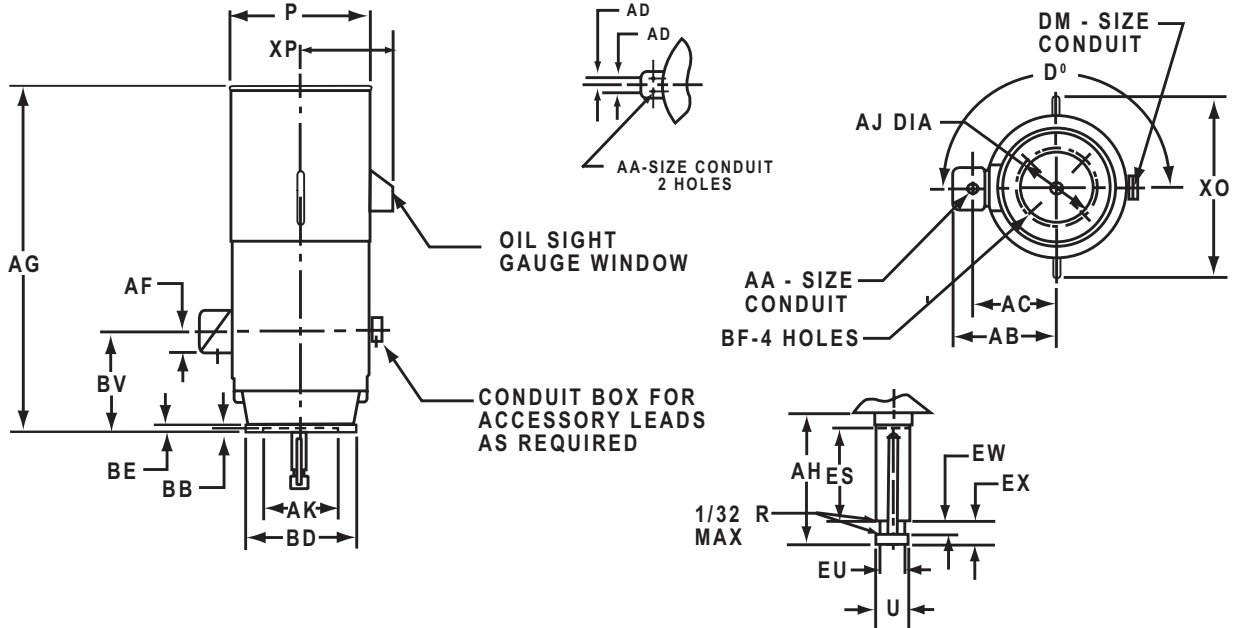

ALL DIMENSIONS ARE IN INCHES

FRAME	BD	BE	AJ	BF	AK +.005	BB	P	XO	XP
5008P	24.5	1.25	14.75	0.687	13.500	0.25	27.5	33.625	16.5
5008PH	20								

FRAME	VOLT	AA	AB	AC	AD	AF	D°	DM	AG	BV
5008	460	3.5	24	17.312	-	5.625	157.5	0.75	63.625	23.75
	2300					8.625				
	4000					8.625				

	POLES (RPM)				U -.001	AH ±.062	ES MIN	EU -.005	EX -.005	EW +.002	SQ KEY
	2 (3600)	4 (1800)	6 (1200)	8 (900)							
HP	ALL	ALL THRU 300	ALL THRU 200	ALL THRU 150	2.125	4.500	3.000	1.750	0.750	0.375	0.5
	---	350	250 THRU 300	200	2.375	5.000	3.500	2.000	0.750	0.375	0.625
	---	---	---	250	2.625	5.000	3.500	2.250	0.750	0.375	0.625
	---	---	---	---	---	---	---	---	---	---	---

	POLES (RPM)				U -.001	AH ±.062	ES MIN	EU -.005	EX -.005	EW +.002	SQ KEY
	10 (720)	12 (600)	14 (514)	16 (450)							
HP	ALL THRU 125	ALL THRU 100	ALL THRU 75	ALL THRU 75	2.125	4.500	3.000	1.750	0.750	0.375	0.5
	150	125 THRU 150	100 THRU 125	100	2.375	5.000	3.500	2.000	0.750	0.375	0.625
	200	---	---	---	2.625	5.000	3.500	2.250	0.750	0.375	0.625
	---	---	---	---	---	---	---	---	---	---	---

TOLERANCES	
FACE RUNOUT	.007 T.I.R.
PERMISSIBLE ECCENTRICITY OF MOUNTING RABBET	.007 T.I.R.
PERMISSIBLE SHAFT RUNOUT	.003 T.I.R.
MAXIMUM SHAFT END PLAY	.010

- ROUGH CASTING DIMENSIONS MAY VARY BY +/- 1/4" DUE TO CASTING AND/OR FABRICATION VARIATIONS.
- CONDUIT OPENING MAY BE LOCATED IN STEPS OF 90 DEGREES STANDARD IS AS SHOWN WITH CONDUIT OPENING DOWN.

† All marks shown within this document are properties of their respective owners.



DIMENSIONS

TEFC/HAZARDOUS LOCATION

SOLID SHAFT

FRAME: 5800P

TYPES: JV-4 & EV-4



Typical Dimensions For Reference Only

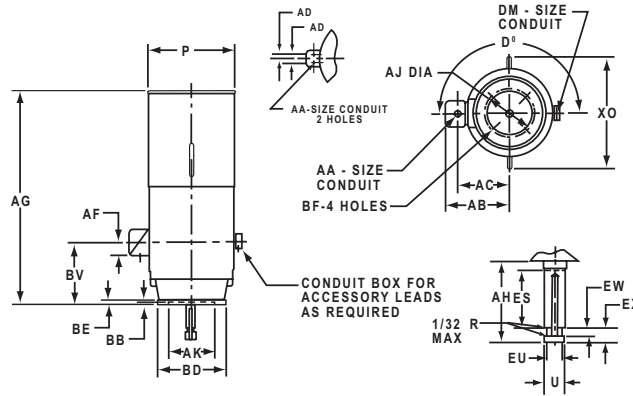

ALL DIMENSIONS ARE IN INCHES

FRAME	HP	TYPE	VOLTS	AA	AB	AC	AD	AF	D°	DM
5800	THRU 500	JV-4	460	3.5	26.125	20.625	---	8.062	180	0.75
	ALL	JV-4	2300		32.38	23.75	3	10.937		
	OVER 500	JV-4	460		27.125	21.625	---	10		
	ALL	JV-4	4000							
	THRU 500	EV-4	460	3.5	26.125	19.437	---	5.625	180	0.75
	ALL	EV-4	2300							
	OVER 500	EV-4	460		32	21.625	3	8.625		
	ALL	EV-4	4000							

FRAME	AG	FRAME	BD	BE	AJ	BF	AK +.005	BB	P	XO	XP	BV
5807	73.687	5808P	30.5	1.25	26	0.812	22.000	0.25	31.125	38.5	17.625	16.75
5809	80.687	5808PH	24.5		14.75	0.687	13.500					
5811	88.687				22	0.937						

HP	POLES (RPM)				U -.001	AH ±.062	ES MIN	EU -.005	EX -.005	EW +.002	SQ KEY
	2 (3600)	4 (1800)	6 (1200)	8 (900)							
HP	ALL THRU 600	ALL THRU 300	ALL THRU 200	ALL THRU 150	2.125	4.500	3.000	1.750	0.750	0.375	0.5
	---	350 THRU 450	250 THRU 300	200	2.375	5.000	3.500	2.000	0.750	0.375	0.625
	---	500 THRU 600	350 THRU 400	250 THRU 300	2.625	5.000	3.500	2.250	0.750	0.375	0.625
	---	700 THRU 800	450 THRU 500	350 THRU 400	2.875	7.000	5.000	2.375	1.000	0.500	0.75
	---	---	600	450 THRU 500	3.125	7.000	5.000	2.625	1.000	0.500	0.75

HP	POLES (RPM)				U -.001	AH ±.062	ES MIN	EU -.005	EX -.005	EW +.002	SQ KEY
	10 (720)	12 (600)	14 (514)	16 (450)							
HP	ALL THRU 125	ALL THRU 100	ALL THRU 75	ALL THRU 75	2.125	4.500	3.000	1.750	0.750	0.375	0.5
	150	125 THRU 150	100 THRU 125	100	2.375	5.000	3.500	2.000	0.750	0.375	0.625
	200	200	150	125 THRU 150	2.625	5.000	3.500	2.250	0.750	0.375	0.625
	250 THRU 300	250	200	200	2.875	7.000	5.000	2.375	1.000	0.500	0.75
	350 THRU 400	300	250	250	3.125	7.000	5.000	2.625	1.000	0.500	0.75

TOLERANCES	
FACE RUNOUT	.007 T.I.R.
PERMISSIBLE ECCENTRICITY OF MOUNTING RABBET	.007 T.I.R.
PERMISSIBLE SHAFT RUNOUT	.003 T.I.R.
MAXIMUM SHAFT END PLAY	.010

- ROUGH CASTING DIMENSIONS MAY VARY BY +/- 1/4" DUE TO CASTING AND/OR FABRICATION VARIATIONS.
- CONDUIT OPENING MAY BE LOCATED IN STEPS OF 90 DEGREES STANDARD IS AS SHOWN WITH CONDUIT OPENING DOWN.

† All marks shown within this document are properties of their respective owners.



DIMENSIONS
TEFC
SOLID SHAFT
FRAME: 5812 VP, VPA

TYPES: JV-4

PRINTS
5812
JV-4

Typical Dimensions For Reference Only

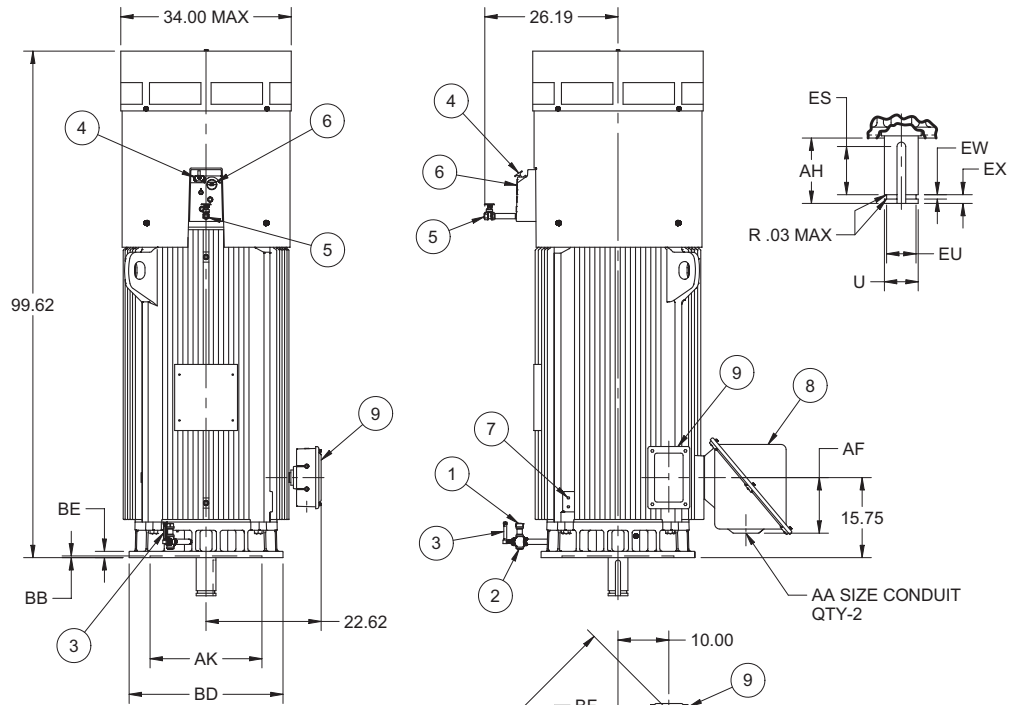

C/BOX VOLUME (CU. IN.)	AB	AC	AD	AF
3400	34.19	25.13	3.00	10.94

C/BOX VOLUME (CU. IN.)	AB	AC	AD	AF
3400	34.19	25.13	3.00	10.94

U	AH	ES	EU	EW	EX	SQ KEY
.001	±.062	MIN	-.005	+.002	-.005	1.000
3.875	7.5	5.500	3.375	.500	1.000	1.000

FRAME	AJ	AK	BB	BD	BE	BF	QTY OF BF HOLES
5812VPZ	26.00	22.000	.25	30.50	1.25	.813	4
5812VPAZ	32.00	26.000		36.00		1.000	

AA	DM
2 NPT	0.5 NPT
2.5 NPT	0.75 NPT
3 NPT	1 NPT
3.5 NPT	1.25 NPT
4 NPT	1.25 NPT

ALL DIMENSIONS ARE IN INCHES

FEATURE LISTING

1	LOWER SUMP OIL FILL	6	UPPER SUMP SIGHT WINDOW
2	LOWER SUMP OIL DRAIN	7	GRD PADS, DIAG OPP, 1/2-1/3
3	LOWER SUMP SIGHT WINDOW	8	MAIN CONDUIT BOX
4	UPPER SUMP OIL FILL	9	ACCESSORY CONDUIT BOX
5	UPPER SUMP OIL DRAIN		

TOLERANCES

FACE RUNOUT	.007
PERMISSIBLE ECCENTRICITY OF MOUNTING RABBET	.007 T.I.R.
PERMISSIBLE SHAFT RUNOUT	.003 T.I.R.
MAXIMUM SHAFT END PLAY	.010
NON-MACHINED DIMENSIONS MAY VARY BY ±25	



† All marks shown within this document are properties of their respective owners.

DIMENSIONS

TEFC

HOLLOSHAFT®

FRAME: 6812VP, VPA, VPB

TYPES: JV4

PRINTS

6812

JV4

Typical Dimensions For Reference Only

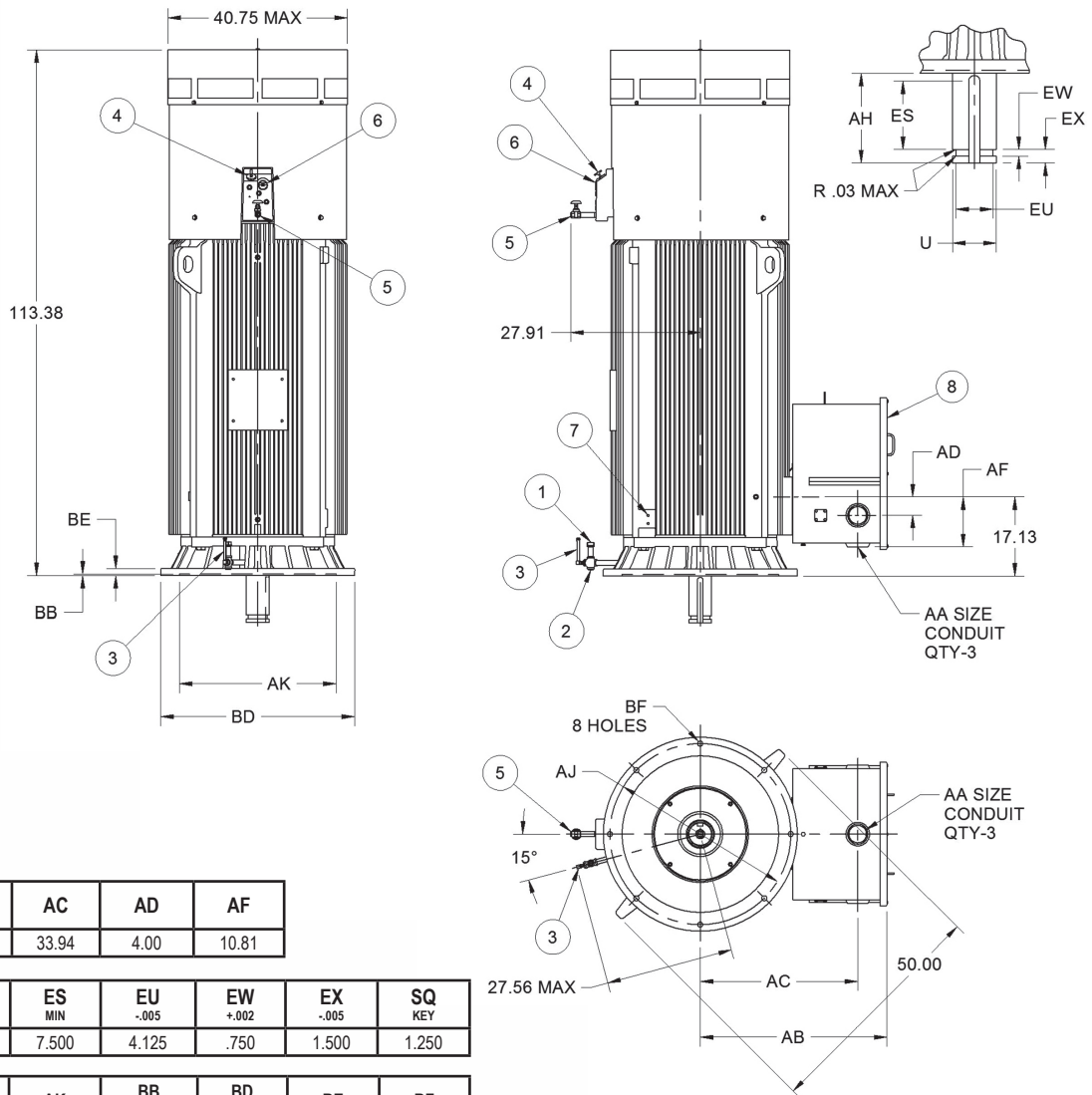

AA
2 NPT
2 1/2 NPT
3 NPT
3 1/2 NPT
4 NPT

C/BOX VOLUME (CU. IN.)	AB	AC	AD	AF
16.200	40.13	33.94	4.00	10.81

U	AH	ES	EU	EW	EX	SQ KEY
.001	±.062	MIN	-.005	+.002	-.005	
4.875	10.000	7.500	4.125	.750	1.500	1.250

FRAME	AJ	AK	BB MIN	BD MAX	BE	BF
6812VP	26.00	22.000	.31	30.50	1.50	.813
6812VPA	32.00	26.000		36.00		1.000
6812VPB	39.00	33.750		42.00		1.125

FEATURE LISTING

1	LOWER SUMP OIL FILL	6	UPPER SUMP SIGHT WINDOW		
2	LOWER SUMP OIL DRAIN	7	GRD PADS, DIAG OPP, .50-13		
3	LOWER SUMP SIGHT WINDOW	8	MAIN CONDUIT BOX		
4	UPPER SUMP OIL FILL				
5	UPPER SUMP OIL DRAIN				

ALL DIMENSIONS ARE IN INCHES

TOLERANCES	22.000 AK	26.000 AK 33.750 AK
FACE RUNOUT	.007T.I.R.	.009 T.I.R.
PERMISSIBLE ECCENTRICITY OF MOUNTING RABBET	.007T.I.R.	.009 T.I.R.
PERMISSIBLE SHAFT RUN OUT	.003 T.I.R.	.003 T.I.R.
MAXIMUM SHAFT END PLAY	.010	.010
TOLERANCE ON AK-DIMENSION	+.005	+.007
NON-MACHINED DIMENSIONS MAY VARY BY ±.25		



† All marks shown within this document are properties of their respective owners.

NOTES



NOTES



NOTES



Typical Solid Shaft Motor Construction

1. Optional Cooling Coils
2. Bearing Temperature Probe Provision
3. Oil Sight Glass
4. Oversize Oil Sump
5. Oil Sight Glass
6. Bearing Temperature Probe Provision
7. Oil Drain
8. Heavy Steel or Cast Iron Fan Cover Guard
9. Precision Bearings (Multiple Options)
10. Rugged Cast Iron Frame, Brackets
11. Multiple Conduit Box Options

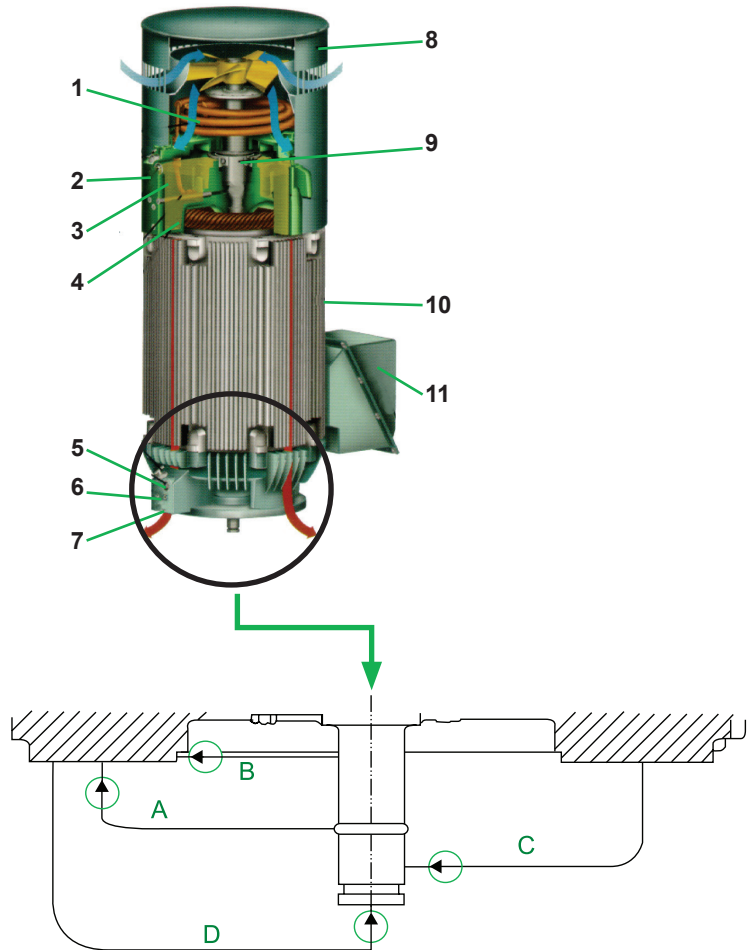

KEY

- A. Face Runout (0.001 in max tolerance)
- B. Register Runout (0.004 in max tolerance)
- C. Shaft Runout (0.001 in max tolerance)
- D. End Play (0.005 in max tolerance)

More than 100 years of vertical motor design experience ensures U.S. MOTORS® brand solid shaft high-thrust motors provide reliability and long life when used in typical applications within harsh process industries such as water/wastewater treatment, and the oil, gas, and refining industries. These motors are constructed of high quality materials and are manufactured in a state-of-the-art, ISO9000-2000 facility. U.S. MOTORS brand vertical solid shaft high-thrust motors meet specifications for use on vertical API† 610 Process turbine applications such as booster, transfer, pipeline, chemical process and refinery water treatment facilities.

†All marks shown within this document are properties of their respective owners.



Nidec Motor Corporation, © 2025; All Rights Reserved.
 U.S. MOTORS® is a registered trademark of Nidec Motor Corporation.
 Nidec Motor Corporation trademarks followed by the ® symbol are registered with the U.S. Patent and Trademark Office.

CAT PB500 Rev. 07/2025

Nidec
 NIDEC MOTOR CORPORATION

8050 W. Florissant Avenue | St. Louis, MO 63136
 Phone: 888-637-7333 | Fax: 866-422-7758
www.nidec-motor.com | www.usmotors.com